

VESSEL

STATIC SOLUTIONS





Fan Type	260 - 261
Gun Type	262 - 263
Nozzle Type	264
Stat Buster	265
Bar Type	266 - 269
Ion Parts Cleaner	270 - 272
EPA Systems	273 - 277
Clean Walker	278 - 279

STATIC SOLUTIONS

HAND TOOLS

INDUSTRIAL BITS

CONSTRUCTION BITS

RECIPROCATING SAW BLADES

ELECTRIC TOOLS

AIR TOOLS

AIR NIPPERS

STATIC SOLUTIONS

GASOLINE ENGINE TOOLS

Butterfly louvers for diffusing ions toward different directions; straight or wide.



Fan type (electrostatic neutralization)

F-6R

Being compact, it is suitable for incorporation into a system. The F-6 with a clip can be mounted on a pipe of a cell production table and used for static elimination of part shelves or nearby working areas.

»261

F-120

This is the popular model of bench-top type, supporting a wide range of applications, from assembling into a unit, to at-hand work. The air flow direction through the louvers can be switched, either diffusion or straight.

»261

CF

This type supports static elimination from wide areas. It adopts a cross-flow fan. It can be installed in an area close to a conveyor or transfer system to remove static electricity from charged objects.

»261



Operation lamp enabling the status to be seen at a glance



Nozzle type (Electrostatic neutralization and dust removal)

This type enables a pinpoint elimination of static electricity and dust from charged objects. It is suitable for installation in equipment or for transfer equipment, including transfer apparatus such as vibratory bowl feeders.

»264
»265



RoHS

Environmental measures

Pb (lead) / Cd (cadmium) / Hg (mercury) / Hexavalent chromium / PBB (polybrominated biphenyl) / PBDE (polybrominated diphenyl ether) / DEHP, BBP, DBP, DIBP (phthalate esters)

The products with this mark in this catalogue are compliant with the RoHS directives (EU) (usage limit of the above 10 substances).

Note: For the updated information on RoHS compliant products, visit our homepage, because some products or sizes are under investigation or are not compliant at the time of publication of this catalogue.

Ion creation method

AC high frequency

Electrostatic eliminators adopting a high-frequency transformer of 20 kHz to 110 kHz have the features of stable ion balance.

Ion balance (F-120R)

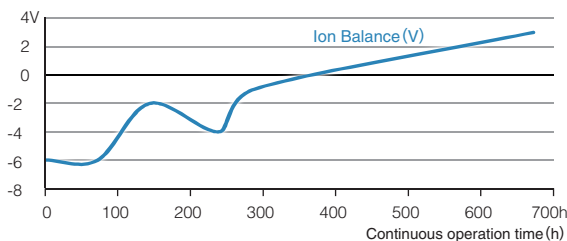

Decay Time (F-120R)

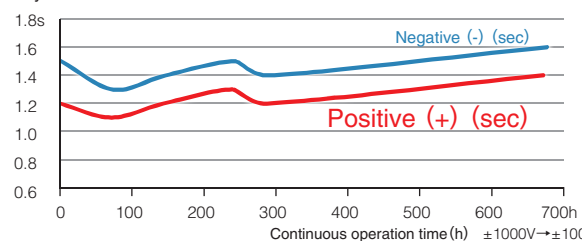

Cautions : Performance varies depending on various conditions such as temperature, humidity, and atmospheric pressure. These pieces of data are our measured values for reference and do not imply the guarantee of the same product performance.



No power supply required. A static and dust removal can be done only with compressed air.



Gun type (dust removal)

A hand-held static eliminator intended primarily for dust removal. It adopts a piezoelectric transformer that is lightweight, compact, and high safety.

»263
»265



Bar type (Electrostatic neutralization, air assist ... dust removal)

This is a bar-type electrostatic eliminator provided with diverse width sizes. It adopts the AC pulse system, allowing you to select an optimal model according to the distance to a charged article.

»267
»269



AC pulse

A pulse AC system that generates positive and negative ions alternatively from individual electrodes. It creates ions in maximum periodic widths of respective positive and negative electrodes; the amount of ions is large, enabling quick electrostatic elimination to be achieved.

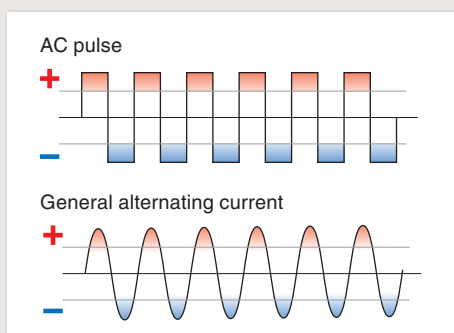

Ion parts cleaner (Electrostatic neutralization, dust removal)

This is a new method of cleaning parts known as ion cleaning. It is capable of performing ion air-based static elimination and dust collection + dust absorption simultaneously.

»271
»272



F-120
Ionizing Fan

Effective static electricity removal



A piezoelectric transformer, which is safe and excellent in ion generation, is adopted. Furthermore, a unique capacitive coupling method, in which the discharge needle is sandwiched between a resin and a stainless steel disk, achieves an unparalleled ion balance. Equipped with easy-to-use functions, such as butterfly louvers with which the airflow directions can be switched, either diffusion or straight, and an external output terminal.

Butterfly Louver

Press near the center, and the ionized air diffuses straight and eliminates static electricity quickly. Press the outer side, and the ionized air is spread by widening the static elimination area.

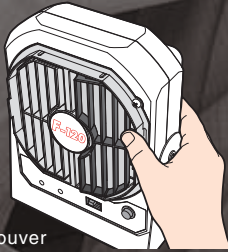

Butterfly Louver



F-120R-E Ionizing Fan

Compactness of the ionizer and ease of its installation during setup and changeover are important for cell production. Stable ion balance is maintained, and the alarm outputs respond to any trouble that may occur. Fan type ionizers effectively remove static electricity according to the customer's application and installation location.

※Image is for illustration purposes.

HAND TOOLS
INDUSTRIAL BITS
CONSTRUCTION BITS
RECIPROCATING SAW BLADES
ELECTRIC TOOLS
AIR TOOLS
AIR NIPPERS
STATIC SOLUTIONS
GASOLINE ENGINE TOOLS

Ionizing Fan

Ionizing method: High-frequency AC corona discharge
Applied voltage: 10kVAC (p-p)

F-120

- Development of small piezoelectric transformer makes the unit slim and compact.
- Butterfly louver function for changing the airflow direction from the front cover.
- Air volume can be adjusted in 3 steps.
- Detachable needle electrode unit improves maintainability.
- Equipped with an abnormality signal output terminal, which is convenient for installation in equipment.

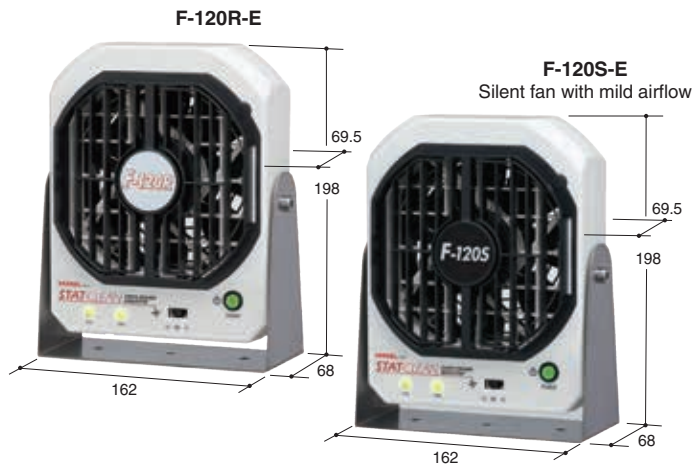

CE F-120R-E

Code No.	Model No.	Power supply	Current consumption (mA) max.	Decay time	Ion balance	Noise level (dBA)	Fan speed (max) (m/min)	Weight (kg)	JAN (4907587)
621651	F-120R-E	24VDC ±5%	700	within 1.5 sec	within ±10V	55	3.66	0.9	019172
621646	F-120S-E	24VDC ±5%	500	within 2.5 sec	within ±10V	51	2.21	0.9	020567

(Decay time, Ion balance: 300mm front and max. fan speed, straight. Noise: 1m front and max. fan speed, straight)
Accessories: Power adapter AD24-ITE (100 - 240VAC), AC input cable (1.8m)
Options: Filter set F-120FS, Filter L-90F

Cross-flow Ionizing Fan

Ionizing method: AC corona discharge
Applied voltage: 9.2kVAC (p-p)

CF

- Superior ionizing performance with the cross-flow fan that sends out the wind widely and evenly and the front cover that is designed with a flow of ions. The air volume can be adjusted steplessly with the airflow adjustment (FAN SPEED) rotary control.
- Slide-type cleaning brush is mounted on the front cover for maintenance of the needle electrodes at any time. Rough filter on the bottom of the main unit for easy cleaning and replacement.
- Monitoring function for abnormal fan motor stop and high voltage output stop.

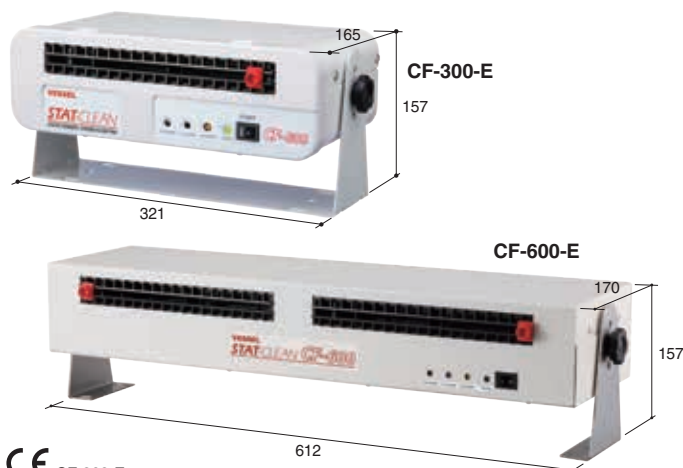

CE CF-300-E

Code No.	Model No.	Power supply	Current consumption (mA) max.	Decay time	Ion balance	Noise level (dBA)	Fan speed (max) (m/min)	Weight (kg)	JAN (4907587)
621657	CF-300-E	24VDC ripple (p-p) ±10% or less	500	within 1.5 sec	within ±10V	48	2.5	2.9	019240
621674	CF-600-E	24VDC ripple (p-p) ±10% or less	900	within 1.5 sec	within ±10V	51.7	2.5	4.6	014566

(Decay time, Ion balance: 300mm front and max. fan speed. Noise: 1m front and max. fan speed)
Accessories (CF-300-E): Power adapter AD24-ITE (100 - 240VAC), AC input cable (1.8m), Cleaning brush 1pc.
Accessories (CF-600-E): Power adapter AD24-IT19E, AC input cable (1.8m), Cleaning brush 2pcs. (mounted), Rubber washer 2pcs, Stand 2pcs, Angle adjustment knob 2pcs.

Ionizing Mini Fan

Ionizing method: AC corona discharge
Applied voltage: 3.5kVAC

F-6R

- Compact and lightweight body.
- Air volume can be adjusted in 2 steps.
- Provided with a clip suitable for mounting (F-6RCL).
- Provided with a general-purpose stand (F-6RST).



CE

Code No.	Model No.	Power supply	Current consumption (mA) typ.	Decay time	Ion balance	Noise level (dBA)	Fan speed (max) (m/min)	Weight (kg)	JAN (4907587)
621663	F-6RCL-E	24VDC ±5%	210	within 3 sec	within ±10V	58.5	0.78	0.52	020192
621662	F-6RST-E	24VDC ±5%	210	within 3 sec	within ±10V	58.5	0.78	0.47	020185

(Decay time, Ion balance: 150mm front and max. fan speed. Noise: 1m front and max. fan speed. Weight: including clip/stand)
Accessories: Power adapter AD24-ITF6E (100 - 240VAC), AC input cable (1.8m)

Overhead Ionizing Triple-Fan

Ionizing method: High-frequency AC corona discharge
Applied voltage: 9.5kVAC (p-p)

L-90-E

- Butterfly louver function for changing the airflow direction from the front cover. Can allocate to each front cover the spot ionizing for high-speed static electricity removal or the area ionizing for wide area static electricity removal. Such combination enables to remove static electricity in various applications.
- Unique capacitive-coupled needle electrodes maintain excellent ion balance and long-term performance.
- Lightweight design.
- The front cover can be removed for easy maintenance of the needle electrode.

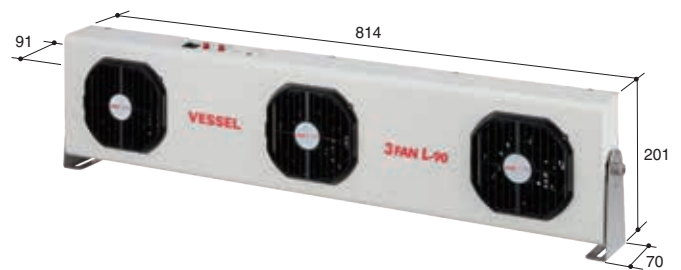

Code No.	Model No.	Power supply	Current consumption (mA) max.	Decay time	Ion balance	Noise level (dBA)	Fan speed (max) (m/min)	Weight (kg)	JAN (4907587)
621628	L-90-E	24VDC ±5%	3.0	within 1.5 sec	within ±10V	75.4	7.1	5.7	019226

(Decay time, Ion balance: 150mm front and max. fan speed. Noise: 1m front and max. fan speed)
Accessories: Power adapter AD24-IT37E (100 - 240VAC), AC input cable (1.8m)

HAND TOOLS

INDUSTRIAL BITS

CONSTRUCTION BITS

RECIPROCATING SAW BLADES

ELECTRIC TOOLS

AIR TOOLS

AIR NIPPERS

STATIC SOLUTIONS

GASOLINE ENGINE TOOLS

G-9

Pneu-Power Ion Gun

Ionizing Revolution!

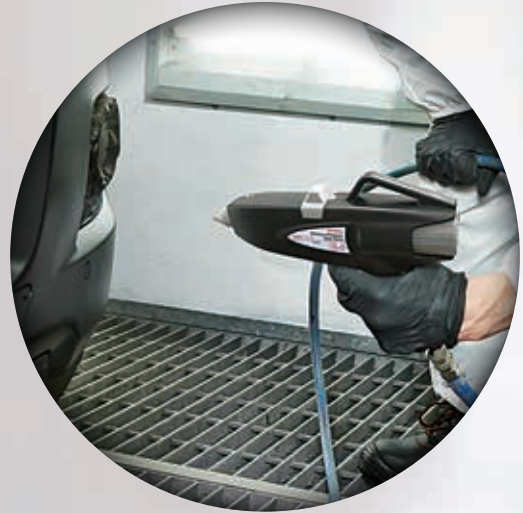

No cable breakage - No repair due to cable

No more "wiring breakdowns," the most frequent trouble with ionizing gun!

No need for a separate high-voltage power supply

No more need for an electrical outlet or long, extended high-voltage cables!

What is needed is an air hose only. Secure the foot space

When moving widely during ionizing, there is few thing that can get caught underfoot!



G-9

Pneu-Power Ion Gun

An air turbine rotates the motor to generate electricity for ion generation. AC adapter or high-voltage wiring is not required; just connect a air hose to the unit, and it is ready to use.

Patented.

※Image is for illustration purposes.

Pneu-Power Ion Gun

Ionizing method: High-frequency AC corona discharge
Applied voltage: 8kVAC(p-p)

I G-9

- No external power supply (power supply wiring) is required.
- Motor cartridge (replaceable) converts compressed air into electric power. The rotating blades in its center rotate to generate electricity, which is then supplied to the high-voltage power supply.
- Patented.



CE

Code No.	Model No.	Applied Voltage/Frequency	Decay time	Ion balance	Noise level (dBA)	Air consumption (l/min)	Weight (g)	JAN (4907587)
621670	G-9	0.5MPa	within 1sec	±30V	74.6	211	470	006158

(Decay time, Ion balance: 150mm front, 0.5MPa, w/Standard nozzle) (Noise: 1.0m at the rear of the product, at 0.5MPa. Air consumption: at 0.5MPa)
 *Operating air pressure: 0.4 - 0.6MPa *Air connection: OD8mm tube applied, one-touch joint
 Accessory: Standard nozzle, Booster nozzle G-9HFN, Instruction manual
 Option: Silent straight nozzle BB-ZSN, Silent nozzle G-9WN, Plug with urethane tube G-9UTP

Ionizing Gun

Ionizing method: High-frequency AC corona discharge
Applied voltage: 6.0kVAC (p-p)

I G-7R-E

- Compact and lightweight resin body
- Ergonomic design that fits in your hand.
- Equipped with a LED lamp for easy visual detection of dust, and lamps for operation status and warning.
- Nozzle can be replaced. Various options are available.
- Needle electrode can be replaced with a dedicated tool (option).



CE

Code No.	Model No.	Power supply	Current consumption (mA)max.	Decay time	Ion balance	Noise level (dBA)	Air consumption (l/min)	Weight (g)	JAN (4907587)
621621	G-7R-E	24VDC ±5%	74	within 1sec	within ±10V	92	180	198	018908

(Decay time, Ion balance: 150mm front, 0.3MPa, w/Standard nozzle)
 (Noise: 1m at the rear of the product. Air consumption: at 0.3MPa)
 *Operating air pressure: 0.1 - 0.6MPa *Operating air hose ID4mm x OD6mm
 Accessories: Power adapter AD24-ITC-E (100 - 240VAC), AC input cable (1.8m), Standard Nozzle G-7SN
 Option: Silent straight nozzle BB-ZSN, Silent nozzle G-9WN, Joint nozzle G-7THN, Brush (60mm bristles) G-7B, Soft Brush (60mm bristles) G-7SB, Speed controller G-7SC, Microfilter G-7F, Relay cable (5m) G-7EC5, Relay cable (10m) G-7EC10, Needle Electrode Replacement Screwdriver G-7DR

Ionizing Gun

Ionizing method: High-frequency AC corona discharge
Applied voltage: 4.5kVAC (p-p)

I G-2-E

- Wiring direction can be changed upward or downward. Easy wiring when the unit is suspended from a cell production stand, etc.
- The electric cable and the air tube can be inserted into the grooves on the lateral side of the grip when the unit is suspended from a tool balancer, etc. This improves work efficiency because the cable and the tube don't get in the way.
- Operation lamps are placed on the top surface of the unit, allowing the user to check the operation status at a glance. Operation ON (Blue), High pressure alarm (Red)



CE

Code No.	Model No.	Power supply	Current consumption (mA)max.	Decay time	Ion balance	Noise level (dBA)	Air consumption (l/min)	Weight (g)	JAN (4907587)
621659	G-2-E	24VDC ±5%	100	within 1sec	within ±10V	94	153	260	019264

(Decay time, Ion balance: 150mm front, 0.3MPa, w/Standard nozzle) (Noise: 1m at the rear of the product, at 0.3MPa. Air consumption: at 0.3MPa)
 *Operating air pressure: 0.1 - 0.6MPa *Operating air hose ID4mm x OD6mm
 Accessories: Standard nozzle N-1SN, Power adapter AD24-ITCS-E (100 - 240VAC), AC input cable (1.8m)

ONE POINT

I G-2-E

Pipe arrangement and wiring can be changed depending on the work

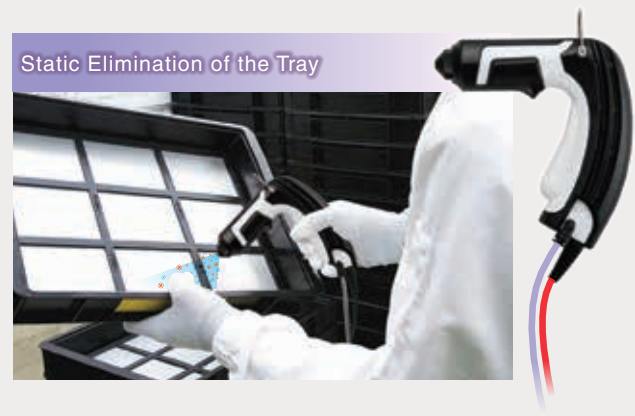

HAND TOOLS

INDUSTRIAL BITS

CONSTRUCTION BITS

RECIPROCATING SAW BLADES

ELECTRIC TOOLS

AIR TOOLS

AIR NIPPERS

STATIC SOLUTIONS

GASOLINE ENGINE TOOLS

Super Slim Ionizing Nozzle

Ionizing method: High-frequency AC corona discharge Applied voltage: 5kVAC(p-p)

N-1

- Compact design allowing installation in any location or direction. Newly developed high-voltage transformer and control circuit for unprecedented ease of use.
- Screw-type nozzle can be easily removed, making nozzle replacement and needle electrode cleaning easy.
- Equipped with a 6-pole terminal to extract a high-voltage abnormality signal and to enable a daisy chain connection of 24VDC power supply.
- The blue lamp lights during normal operation, and the red lamp lights when a high-voltage error occurs.



Code No.	Model No.	Power supply	Current consumption (mA)max.	Decay time	Ion balance	Noise level (dBA)	Air consumption (l/min)	Weight (kg)	JAN (4907587)
621639	N-1	24VDC ±5%	100	within 1sec	within ±10V	94.2	219	62	020512

(Decay time, Ion balance: 150mm front, 0.3MPa, w/Standard nozzle)
 (Noise: measured distance of 1m, at 0.3MPa, Air consumption: w/Standard nozzle, at 0.3MPa)
 *Operating air pressure: 0.1 - 0.6MPa. *Operating air hose ID4mm x OD6mm
 Accessory: Standard nozzle N-1SN
 Options: Silent straight nozzle BB-ZSN, Silent wide nozzle N-2WN, Speed controller G-7SC, Microfilter G-7F, Needle replacement screwdriver G-7DR

ONE POINT

N-1 | N-3

Silent nozzles are available as option.

Daisy-chain wiring.

High voltage cables stay inside the product.



Silent straight nozzle

BB-ZSN

N-1 Noise level 96dBA →86.5dBA

N-3 Noise level 99.4dBA→83.2dBA



Silent wide nozzle

G-9WN

N-1 Noise level 96dBA →95.5dBA

N-3 Noise level 99.4dBA→87.3dBA

(Operating air pressure 0.3MPa. Our measured values at 1m)

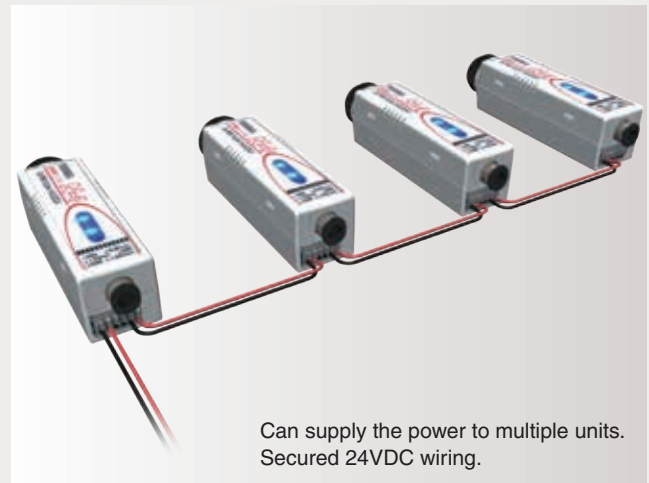

Can supply the power to multiple units. Secured 24VDC wiring.

Pinpoint Ionizing Nozzle

Ionizing method: High-frequency AC corona discharge Applied voltage: 5.6kVAC(p-p)

N-3

- Compact and lightweight. Equipped with screw holes for mounting on equipment.
- Various nozzles are available as options for use in various applications.
- Screw-type nozzle can be easily removed, making nozzle replacement and needle electrode cleaning easy.
- Automatic stop in the event of high voltage abnormality. Equipped with an alarm warning output terminal.
- Equipped with a 6-pole terminal to extract a high-voltage abnormality signal and to enable a daisy chain connection of 24VDC power supply.
- The green lamp lights during normal operation, and the red lamp lights when a high-voltage error occurs.

CE

Code No.	Model No.	Power supply	Current consumption (mA)max.	Decay time	Ion balance	Noise level (dBA)	Air consumption (l/min)	Weight (kg)	JAN (4907587)
621654	N-3	24VDC ±5%	90	within 1sec	within ±10V	99.4	210	104	020666

(Decay time, Ion balance: 150mm front, 0.3MPa, w/Standard nozzle)
 (Noise: measured distance of 1m, at 0.3MPa, Air consumption: w/Standard nozzle, at 0.3MPa)
 *Operating air pressure: 0.1 - 0.6MPa. *Operating air hose ID4mm x OD6mm
 Accessory: Standard nozzle N-1SN
 Options: Silent straight nozzle BB-ZSN, Silent nozzle G-9WN, Speed controller G-7SC, Microfilter G-7F, Needle replacement screwdriver G-7DR

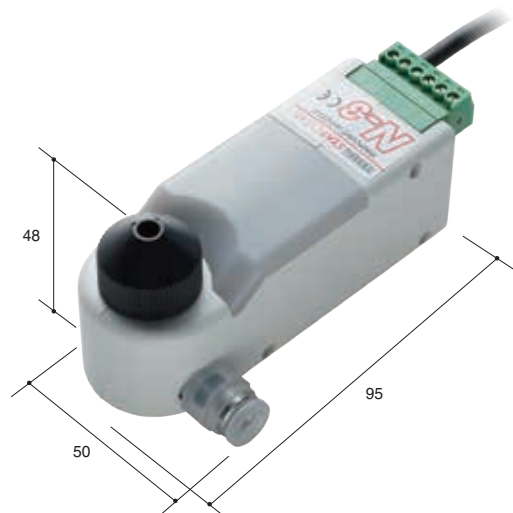

HAND TOOLS

INDUSTRIAL BITS

CONSTRUCTION BITS

RECIPROCATING SAW BLADES

ELECTRIC TOOLS

AIR TOOLS

AIR NIPPERS

STATIC SOLUTIONS

GASOLINE ENGINE TOOLS

High Power Ionizing Gun

Ionizing method: AC corona discharge

HPG-1

- Titanium discharge needle. Less-wearing titanium provides the long-term stable ionizing performance.
 - Provided with the high voltage cable (3m), which is less affected by the external electrical noises.
 - The body of the ionizing gun is made by robust aluminum die-casting. Easy handling large trigger for superior operability.
- ※For power supply, please use the High Voltage Power Supply Unit GP-1 4V, which is available as option.



Code No.	Model No.	Decay time	Noise level (dBA)	Air consumption (ℓ/min)	Weight (g)	JAN (4907587)
623046	HPG-1	within 0.5sec	95	110	560	019318
623050	HPG-1-4.5M	within 0.5sec	95	110	730	010568

(Decay time, Noise, Air consumption: Distance 150mm, Input air pressure 0.3MPa)
 ·Operating air pressure 0.1 - 0.7MPa. ·Operating air hose ID6mm x OD8mm
 ※Cable length: HPG-1 3m, HPG-1-4.5M 4.5m
 Options: High voltage power supply unit No. GP-1 4kV, Power adapter No.AD24-GPE

High Voltage Power Supply Unit

Output voltage : 4kVAC (50/60Hz)

GP-1 4kV

- Equipped with 2 high voltage output connectors for ionizing bars. Easy installation and wiring.
- Ion balance adjustment function.
- Equipped with a safety circuit that automatically stops the output in the event of a high-voltage short circuit or other abnormality.
- Operating status can be output to external devices from the alarm output terminal.

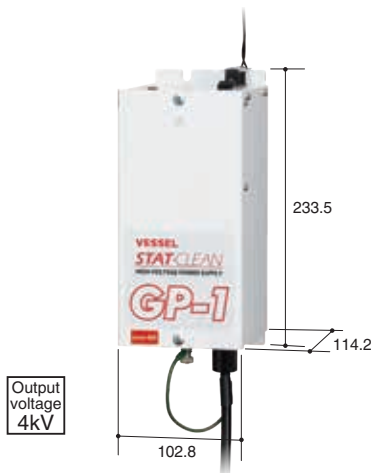

Code No.	Model No.	Power supply	Size (mm)	Weight (g)	JAN (4907587)
623044	GP-1 4kV	24VDC ±10%	233.5×114.2×102.8	4500	019295

Applicable models: HPN-1, HPG-1, HPF-1, SJ-series, SL-series, HPB-series
 Option: Power adapter No.AD24-GPE

High Power Ionizing Nozzle (Shielded cable included)

Ionizing method: AC corona discharge

HPN-1

- Titanium discharge needle. Less-wearing titanium provides the long-term stable ionizing performance.
 - Provided with the high voltage cable (3m), which is less affected by the external electrical noises.
- ※For power supply, please use the High Voltage Power Supply Unit GP-1 4V, which is available as option.

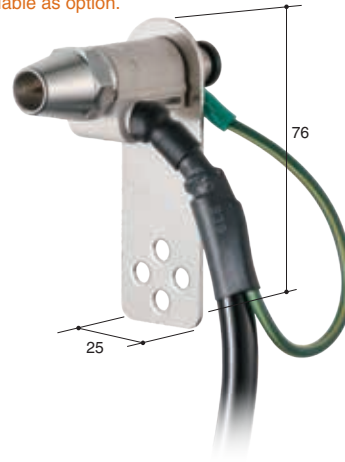

Code No.	Model No.	Decay time	Ion balance	Noise level (dBA)	Air consumption (ℓ/min)	Weight (g)	JAN (4907587)
623043	HPN-1	within 0.5sec	Adjustable on the GP-1 4kV	95	100	350	019288

(Decay time, Noise, Air consumption: Distance 150mm, Input air pressure 0.3MPa)
 ·Operating air pressure 0.1 - 0.6MPa. ·Operating air hose ID4mm x OD6mm
 Accessories: High voltage cable 3m, Standard mounting hardware, High voltage connector
 Options: High voltage power supply unit No. GP-1 4kV, Power adapter No.AD24-GPE

High Power Ionizing Flexible Nozzle

Ionizing method : AC corona discharge

HPF-1

- 300mm flexible tube allows the nozzle tip to be adjusted to any angle.
 - Even in locations where installation is difficult, static electricity can be removed from the specific area of charged objects.
 - Titanium discharge needle. Less-wearing titanium provides the long-term stable ionizing performance.
 - Provided with the high voltage cable (3m), which is less affected by the external electrical noises.
- ※For power supply, please use the High Voltage Power Supply Unit GP-1 4V, which is available as option.

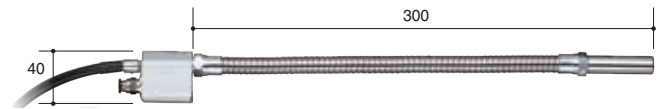

Code No.	Model No.	Decay time	Ion balance	Noise level (dBA)	Air consumption (ℓ/min)	Weight (g)	JAN (4907587)
623048	HPF-1	within 1.0sec	Adjustable on the GP-1 4kV	86	110	690	019332

(Decay time: Distance 150mm, Airflow 30ℓ/min)
 (Noise, Air consumption: Input air pressure 0.3MPa)
 ·Operating air pressure 0.1 - 0.4MPa. ·Operating air hose ID4mm x OD6mm
 Accessories: High voltage cable 3m, High voltage connector
 Options: High voltage power supply unit No. GP-1 4kV, Power adapter No.AD24-GPE

C-40

AC Pulse Ionizing Clean Bar

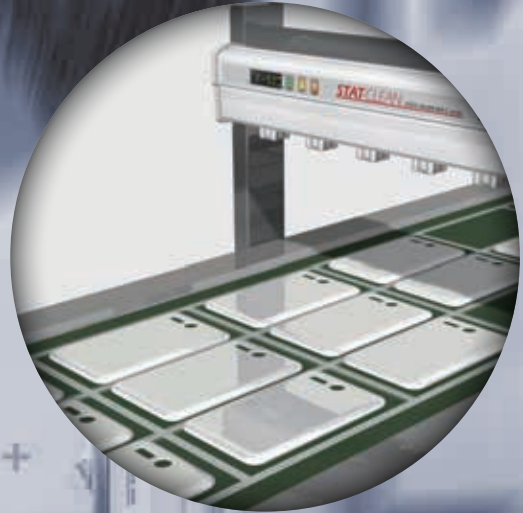

The auto ion balance mode automatically adjusts the ion balance according to the polarity of the charged object, and 10 levels of frequency can be set to suit the installation distance and the charge amount.

Air purge structure for High-speed static electricity removal

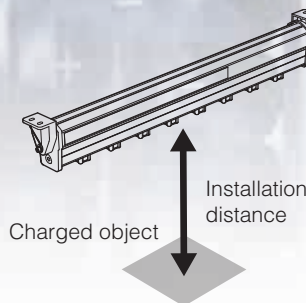

Frequency setting

Installation place	Location	mm	Frequency, Hz
Film/conveyor	Close distance	50~300	20~50
Clean bench	Intermediate distance	600~750	8~10
Clean room ceiling	Long distance	900~1500	0.1~5

C-40

AC Pulse Ionizing Clean Bar

Ionizing bars ideal for installation in various types of equipment. A wide range of sizes are available to meet various applications.

HAND TOOLS
INDUSTRIAL BITS
CONSTRUCTION BITS
RECIPROCATING SAW BLADES
ELECTRIC TOOLS
AIR TOOLS
AIR NIPPERS
STATIC SOLUTIONS
GASOLINE ENGINE TOOLS

AC Pulse Ionizing Clean Bar

Ionizing method: Pulse AC corona discharge Applied voltage: 8~12.5kVAC(p-p) **I C-series**

- Ultra compact design with built-in high voltage power supply and control circuit.
- Terminals are integrated on one side, allowing daisy-chaining.
- Newly developed needle electrode socket has an air purge structure with air jets around the needle electrode. This not only prevents contamination of the tip of the discharging needle, but also enables ultra high-speed ionization.
- Counter electrode is built into the body. Prevents particles from adhering to the outside of the housing due to induced voltage, minimizes loss of applied voltage, and improves ion generation efficiency. Needle electrode socket type for easy and one-touch needle replacement.
- Equipped with an auto-balance mode that automatically adjusts to the optimal ion balance according to the polarity of the charged object (target distance 50~100 mm).
- Pulse ratio can be adjusted in 0.1% increments.



Accessories : AC cable (5m)
Remote Control RMC-01 (Except C-40/C-60)
End brackets 2pcs,
Middle Bracket (Quantity See below)

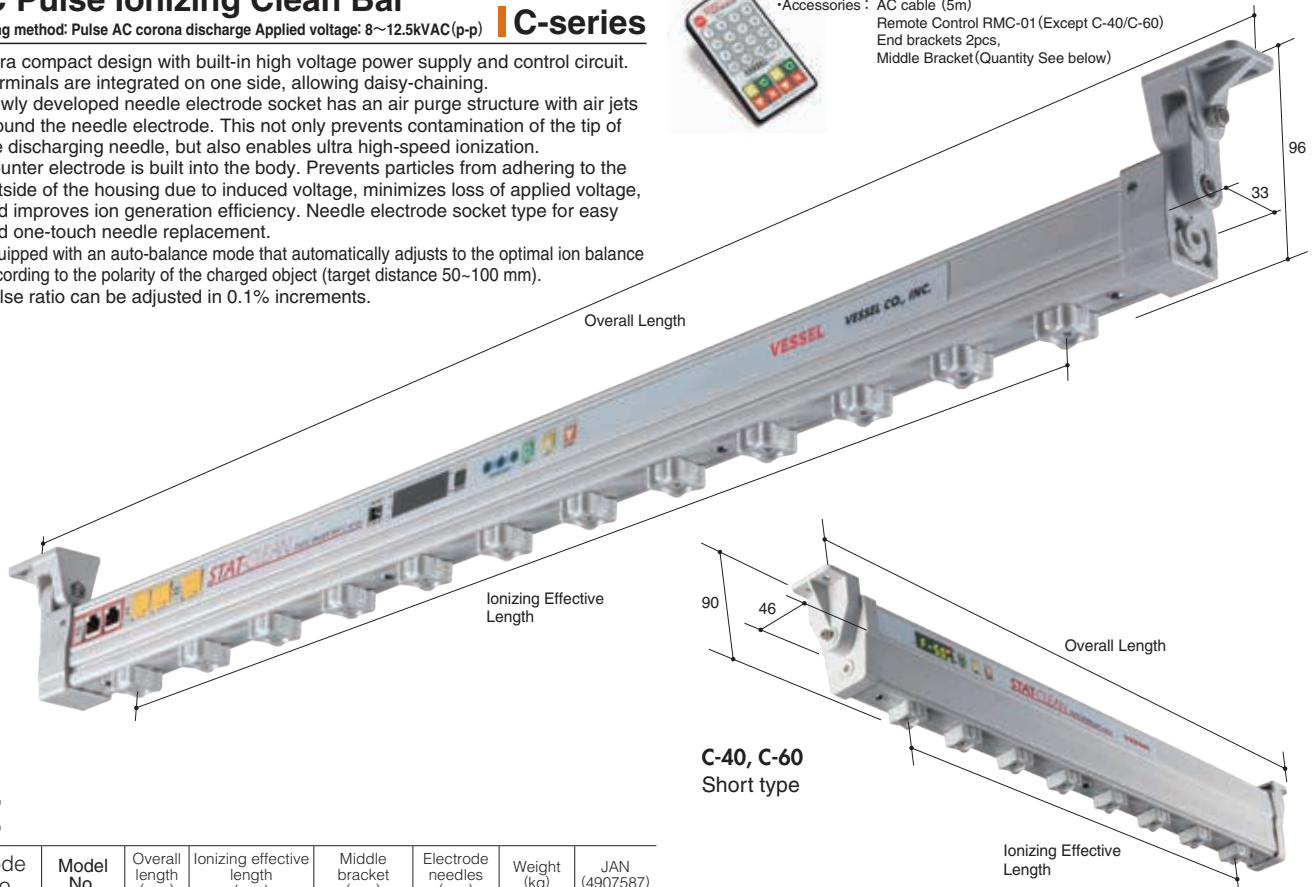

Code No.	Model No.	Overall length (mm)	Ionizing effective length (mm)	Middle bracket (pcs)	Electrode needles (pcs)	Weight (kg)	JAN (4907587)
621851	C-90	877	660	0	12	0.9	020406
621852	C-100	1078	900	1	16	1	020413
621853	C-120	1318	1140	1	20	1.2	020420
621854	C-150	1558	1380	1	24	1.4	020437
621855	C-170	1798	1620	2	28	1.6	020444
621856	C-200	2038	1860	2	32	1.8	020451
621859	C-220	2278	2100	2	36	2.3	020338
621860	C-250	2518	2340	3	40	2.6	020345
621861	C-270	2758	2580	3	44	2.8	020352
621862	C-300	2998	2820	3	48	3.1	020369

Power supply	Current consumption (mA) max.	Decay time ※	Frequency adjustment	Pulse ratio adjustment	Voltage level
24VDC±5%	600	within 0.8sec	13steps (0.1~50Hz)	+ : 40~70% (- : 60~30%)	±10steps each

(※Decay time :30Hz, 10.5kVp-p, 300mm directly below, at 0.3MPa)
 ·Operating air pressure※... 0 - 0.3MPa ·Operating air hose ID6 x OD8mm (Air supply port PT1/8)
 Accessories: Remote controller, Power cable (10m) x 1, Signal cable (10m) x 1,
 End bracket x 2, Middle bracket (see the above table)
 Options: Power adapter AD24-ITE, AD24-IT19E, Power supply cable (5m) CT-5

AC Pulse Ionizing Clean Bar

Ionizing method: Pulse AC corona discharge Applied voltage: 8~12.5kVAC(p-p) **C-40/C-60**

- Short type ideal for installation on conveyors or inside equipment.
- Terminals are integrated on the back side, allowing daisy-chaining.



Code No.	Model No.	Overall length (mm)	Ionizing effective length (mm)	Electrode needles (pcs)	Weight (kg)	JAN (4907587)
621857	C-40	422	240	5	0.78	020468
621858	C-60	602	420	8	1.08	020475

Power supply	Current consumption (mA) max.	Decay time※	Frequency adjustment	Pulse ratio adjustment	Voltage level
24VDC±5%	600	within 0.8sec	10steps (0.1~50Hz)	+ : 40~70% (- : 60~30%)	±10steps each

(※Decay time :30Hz, 10.5kVp-p, 300mm directly below, at 0.3MPa)
 ·Operating air pressure: 0 - 0.3MPa ·Operating air hose ID6 x OD8mm (Air supply port PT1/8)
 Accessories: Power cable (10m) x 1, Signal cable (10m) x 1, End bracket x 2
 Options: Power adapter AD24-ITE, AD24-IT19E, Power supply cable (5m) CT-5

ONE POINT I C-series

AC Pulse Auto Balance Mode

Equipped with an auto-balance mode that automatically adjusts to the optimal ion balance according to the polarity of the charged object (target distance 50~100 mm).
 ※C-series (except C-40 and C-60)

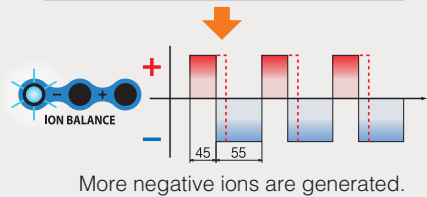
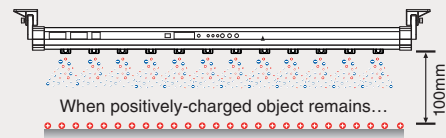

AC pulse method

Pulse AC method that alternately generates positive/negative ions from each electrode.
 Ions are generated at the maximum cycle width of each positive/negative electrode, resulting in a large amount of ions and rapid static elimination.

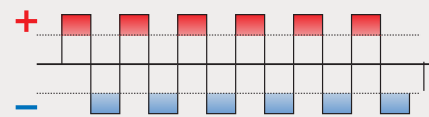

Typical alternating current

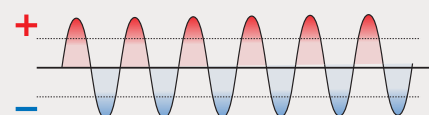

Ionizing Bar

Ionizing method: Pulse AC corona discharge

- Slim & compact design.
- Needle electrode is detachable and replaceable.
- High voltage cable is detachable.
- Brackets allow the change in the angle after installation.
- A wide selection of sizes to best suit your production line.

*Use optional high-voltage power supply unit GP-1 4kV or SH-G3.

SJ- / SL-series



Discharge needles can be cleaned and replaced while the ionizing bar remains installed.



SL-30

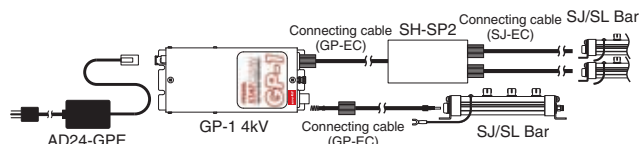

1 high-voltage power supply unit (No.GP-1 4kV)(option) can supply the power to 2 ionizing bars (maximum).
With the branch box (option), 3 ionizing bars (maximum) can be used.

CE SL-series

Code No.	Model No.	Overall length (mm)	Ionizing effective length (mm)	Electrode needles (pcs)	Weight (kg)	JAN (4907587)
621591	SJ-20	208	80	3	0.2	019462
621878	SL-30	368	240	7	0.3	007629
621879	SL-50	528	400	11	0.7	007636
621880	SL-80	848	720	19	0.9	007643
621881	SL-120	1,168	1,040	27	1.1	007650
621882	SL-150	1,488	1,360	35	2.0	007667
621597	SJ-180	1,808	1,680	43	2.2	019523

*SJ-series is available while the current stock lasts. The SJ-series are switched to the SL-series accordingly.
*Air consumption 135L/min (SL-30, Air pressure 0.3MPa) *Decay time: 1sec. or less (Distance 300mm)
Accessory: Grounding wire
Options: Connecting cable GP-EC25, GP-EC5, SL-EC2.5, SJ-EC5, Needle electrode unit SJ-00HR

High Voltage Power Supply Unit GP-1 4kV

Output voltage : 4kVAC (50/60Hz)

- Equipped with 2 high voltage output connectors for ionizing bars. Easy installation and wiring.
- Ion balance adjustment function.
- Equipped with a safety circuit that automatically stops the output in the event of a high-voltage short circuit or other abnormality.
- Operating status can be output to external devices from the alarm output terminal.

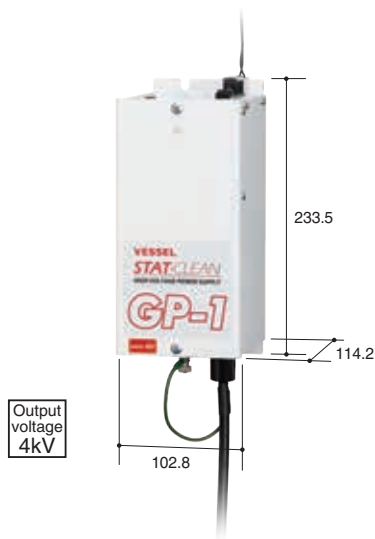

High Voltage Power Supply Unit SH-G3

Output voltage: 5kVAC(p-p)(Pulse AC corona discharge)

- Equipped with 2 sockets for ionizing bars. Easy installation and wiring.
- Ion balance adjustment function (pulse ratio).
- Industry's lightest weight body 1.35kg.



Code No.	Model No.	Input power supply	Power consumption (W)	Frequency (Hz)	Plus ratio	Weight (kg)	JAN (4907587)
621555	SH-G3	100~240VAC (50/60Hz)	10	30	+ : 40~70% - : 60~30%	1.35	020154

Accessories: AC power cable x 2 (for 100VAC/240VAC) 1.8m

Branch Box SH-SP2

- One output can be branched into two.

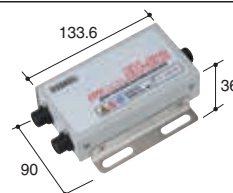

Code No.	Model No.	Power supply	Size (mm)	Weight (kg)	JAN (4907587)
623044	GP-1 4kV	24VDC ±10%	233.5×114.2×102.8	4.5	019295

Applicable models: HPN-1, HPG-1, HPF-1, SJ-series, SL-series, HPB-series, SH-SP2
Option: Power adapter No.AD24-GPE

Code No.	Model No.	Applicable models	Weight (kg)	JAN (4907587)
621552	SH-SP2	SJ- / SL-Series	0.35	018762

Applicable power supply unit: GP-1 4kV, SH-G3

HAND TOOLS
INDUSTRIAL BITS
CONSTRUCTION BITS
RECIPROCATING SAW BLADES
ELECTRIC TOOLS
AIR TOOLS
AIR NIPPERS
STATIC SOLUTIONS
GASOLINE ENGINE TOOLS

High Power Ionizing Bar

Ionizing method : Pulse AC corona discharge Applied voltage : 3.5kVAC(50/60Hz)

HPB-series

- Ultra-slim design, ideal for installation in a narrow space inside equipment.
 - Titanium needle electrodes are used to minimize electrolytic corrosion and wear.
 - High-voltage cable is flexible and durable silicon shielded cable.
 - Ion balance adjustment, abnormality detection, automatic shutdown, and alarm output are supported by the No. GP-1 4KV high-voltage power supply unit (sold separately).
 - Air assist bar is also available as an option.
- ※Use optional high-voltage power supply unit GP-1 4kV(sold separately).

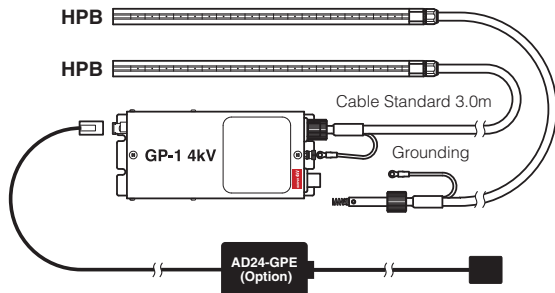
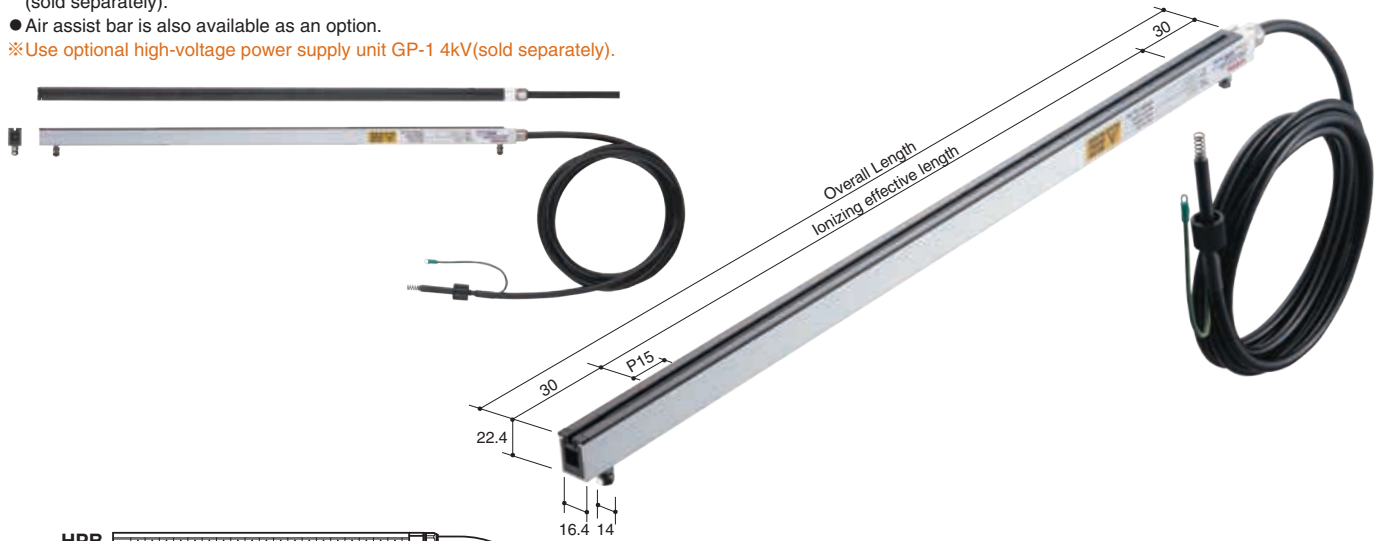

- 1 high-voltage power supply unit (No.GP-1 4kV)(option) can supply the power to 2 ionizing bars (maximum).
- The cable length can be customized on request (option), but when connecting 2 ionizing bars, the total length should be less than 9 m, including the total length of all bars which are connected.

Code No.	Model No.	Overall length (mm)	Ionizing effective length (mm)	Electrode needles (pcs)	Weight (g)	JAN (4907587)
623316	HPB-300	300	240	17	501	022035
623336	HPB-600	600	540	37	662	022233
623350	HPB-810	810	750	51	774	022370
623363	HPB-1005	1,005	945	64	879	022509
623376	HPB-1200	1,200	1,140	77	988	022639
623396	HPB-1500	1,500	1,440	97	1,148	022837
623416	HPB-1800	1,800	1,740	117	1,309	023032

*Decay time: Approx. 2sec. (no air, distance 100mm)
 Accessories: Instruction manual, High voltage cable (mounted), Installation bolts M5 (mounted)
 Option: Air Assist Bar AAB

HAND TOOLS

INDUSTRIAL BITS

CONSTRUCTION BITS

RECIPROCATING SAW BLADES

ELECTRIC TOOLS

AIR TOOLS

AIR NIPPERS

STATIC SOLUTIONS

GASOLINE ENGINE TOOLS

HAND TOOLS

INDUSTRIAL BITS

IPC-V4

Ion Parts Cleaner Vertical Type

Install the machine underfoot. Effective use of the space.



This vertical cleaner enhances work efficiency. The opening is on the top and the installation area is A4 size, which takes up little space, allowing for greater flexibility in the layout of the work area. For example, if it is installed between two workers, it can be used by both of them.



Powerful ionized air eliminates static electricity and blows away dust adhered on the workpiece. Pulse air function can also be selected to enhance the cleaning effect.

- ▶ No need to move to a clean bench for cleaning work.
- ▶ Workpiece can be inserted from the top opening with one hand, so the work flow is efficiently organized.
- ▶ Dust does not scatter, unlike an air gun.



IPC-V4

Ion Parts Cleaner Vertical Type

Ion parts cleaners play an important role in the cell production process.

Assembled parts and devices can be cleaned by ionized air on the spot and transferred to the next process, making production line design smarter.

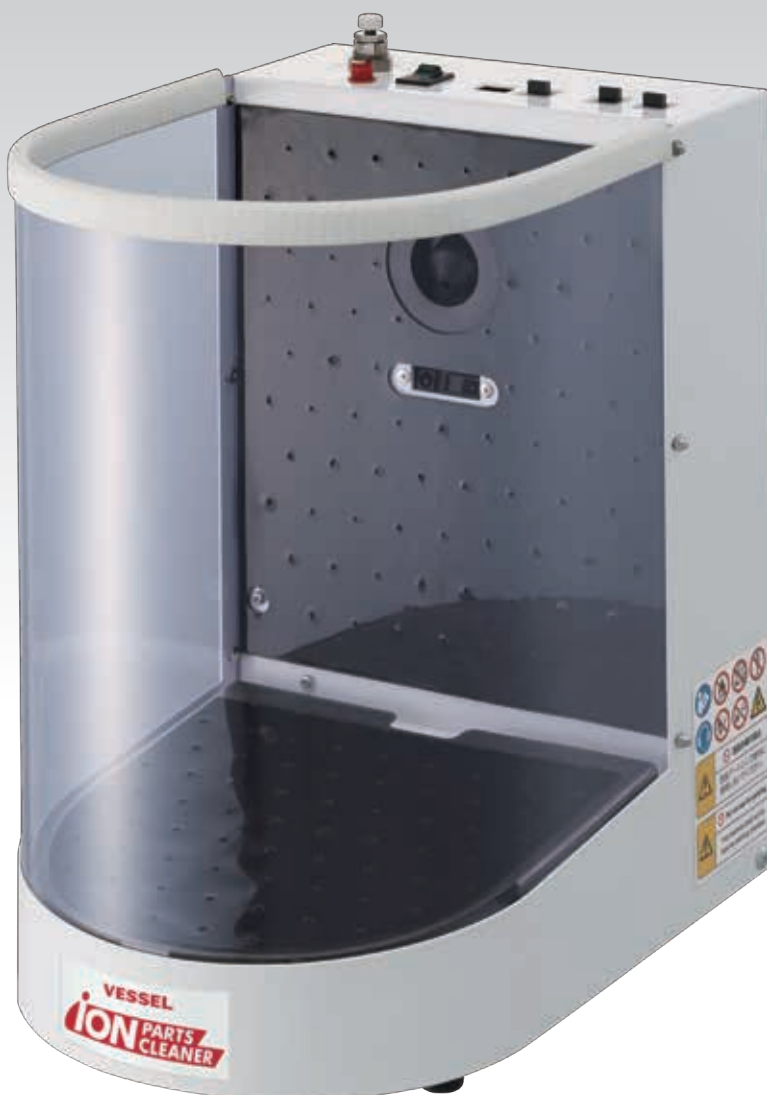

CONSTRUCTION BITS

RECIPROCATING SAW BLADES

ELECTRIC TOOLS

AIR TOOLS

AIR NIPPERS

STATIC SOLUTIONS

GASOLINE ENGINE TOOLS

Ion Parts Cleaner

Ionizing method: High voltage AC corona discharge
Applied voltage: 5.6kVAC(p-p)

IPC-A4

- Compact tabletop type with a width of 314mm x depth of 253mm.
- An infrared sensor detects the workpiece and the ion air is automatically discharged to eliminate static electricity and dust.
- The time to stop the ion blow after the sensor detects a workpiece can be set. (1/3/5/10/30 sec.)
- Adhesive gel sheet to increase dust collection efficiency.
- Adhesive gel sheet can be washed with water and used many times.
- Air is discharged intermittently, and a pulse blow function that blows off dust with vibration is also selectable.
- No dust collector is needed, reducing power consumption and running costs. The pulse blow function also reduces air consumption.
- Air flow rate can be adjusted with a built-in controller.



Code No.	Model No.	Power supply	Power consumption (W)	Current consumption (mA)	Dust collection airflow (m ³ /min)	Air consumption (l/min)	Weight (kg)	JAN (4907587)
621610	IPC-A4	24VDC±5%	17	700	3.5	147	6	018960

(Air consumption: at 0.3MPa)
 ·Operating fluid··Clean air (0.1 - 0.6MPa) ·Operating air hose OD8mm
 Accessories: Power adapter AD24-IT19E (100 - 240VAC), AC input cable 1.8m, Adhesive gel sheet plate x 2 (mounted), Non-woven simplified filter (1pc. attached)
 Options: Adhesive gel sheet x 1 IPC-A4G (2pcs. required for 1 unit), Non-woven simplified filter (5-pc set) IPC-A4F, Needle electrode (for N-3) GN-H

Ion Parts Cleaner Vertical Type

Ionizing method : High voltage AC corona discharge
Applied voltage: 5.6kVAC(p-p)

IPC-V4 NEW

- Industry's first(*) dust box type cleaner. *As of March 2022. According to our own research.
- Compact design for easy moving and relocation. Can be installed underfoot.
- When a workpiece is inserted through the top opening, an infrared sensor detects the workpiece and the ion air is automatically discharged to eliminate static electricity and dust.
- The time to stop the ion blow after the sensor detects a workpiece can be set. (1/3/5/10/30 sec.)
- Adhesive gel sheet to increase dust collection efficiency.
- Adhesive gel sheet can be washed with water and used many times.
- Air is discharged intermittently, and a pulse blow function that blows off dust with vibration is also selectable.
- No dust collector is needed, reducing power consumption and running costs. The pulse blow function also reduces air consumption.
- Air flow rate can be adjusted with a built-in controller.



Code No.	Model No.	Power supply	Power consumption (W)	Current consumption (mA)	Dust collection airflow (m ³ /min)	Air consumption (l/min)	Weight (kg)	JAN (4907587)
621611	IPC-V4	24VDC±5% (50/60Hz)	18	1000	1.13	161	3.8	028259

Accessories: Power adapter AD24-IT19E (100 - 240VAC), Adhesive gel sheet for internal wall side (w/magnet sheet) (Already mounted), Adhesive gel sheet plate for bottom side, Paper pack filter (6-pc set), 2P-3P conversion adapter, Tilt adjustment spacer
 Options: Adhesive gel sheet for internal wall side (w/magnet sheet) IPC-V4GB, Adhesive gel sheet plate for bottom side IPC-V4GD, Paper pack filter (6-pc set) IPC-A3F, Needle electrode (for N-3) GN-H

Ion Parts Cleaner

Ionizing method: High voltage AC corona discharge
Applied voltage: 5.6kVAC(p-p)

IPC-A3

- Static elimination from the top of the hood downward. Equipped with 2 pcs of N-3 ionizing nozzle that blow air for dust elimination.
- An infrared sensor detects the workpiece and the ion air is automatically discharged to eliminate static electricity and dust.
- The time to stop the ion blow after the sensor detects a workpiece can be set. (1/3/5/10/30 sec.)
- Adhesive gel sheet to increase dust collection efficiency.
- Adhesive gel sheet can be washed with water and used many times.
- Air is discharged intermittently, and a pulse blow function that blows off dust with vibration is also selectable.
- No dust collector is needed, reducing power consumption and running costs. The pulse blow function also reduces air consumption.
- Air flow rate can be adjusted with a built-in controller.

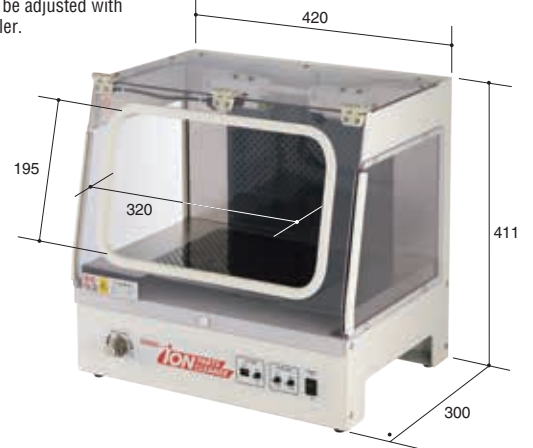

Code No.	Model No.	Power supply	Power consumption (W)	Current consumption (mA)	Dust collection airflow (m ³ /min)	Air consumption (l/min)	Weight (kg)	JAN (4907587)
621612	IPC-A3	24VDC±5%	22	900	1.13	265	9.5	018977

(Air consumption: at 0.3MPa)
 ·Operating fluid··Clean air (0.1 - 0.5MPa) ·Operating air hose OD10mm
 Accessories: Power adapter AD24-IT19E (100 - 240VAC), AC input cable 1.8m, Adhesive gel sheet plate x 2 (mounted), Duct flange for Ø75, Paper pack filter x 6
 Options: Adhesive gel sheet x 1 IPC-A4G (2pcs. required for 1 unit), Paper pack filter (6-pc set) IPC-A3F, Needle electrode (for N-3) GN-H

ONE POINT IPC-A4 / A3 / V4

Convenient functions



Easy to handle with a magnet.

Gel sheet (IPC-A4/A3/V4)

Dust collection by self-adhesive urethane gel. Adhesiveness is restored by wiping the surface of the gel sheet with water to remove dirt. (Can also be wiped with alcohol.)



Paper pack filter (IPC-A3/V4)

A paper pack filter can be attached to the rear exhaust port (standard spec.). A Ø75 mm exhaust duct can be connected by replacing the flange.

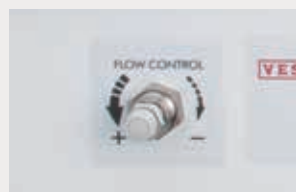

Flow rate adjustment (IPC-A4/A3/V4)

The flow rate of ion air can be adjusted with the built-in flow controller.

Ion Parts Cleaner

Ionizing method : DC Corona discharge Applied voltage : +6kV, -3~-7kV **IPC-250CR**

- HEPA filter is equipped in the machine. It blows out clean air in which 99.97% of particles 0.3 μ m or larger was removed.
- No compressed air required.
- Space-saving installation of 350mm (width) x 345mm(depth).
- Acrylic cover in the front side prevents air diffusion (the cover is removable).
- 270mm(width) x 270mm(depth) x 250 mm(height) space is "static-free".
- Ion balance can be adjusted. Needle electrodes are replaceable.
- With alarm lamps to notify high voltage abnormalities.
- Air blow speed can be adjusted.
- No protrusions or power supply terminals on the back of the machine, making effective use of a narrow working table.
- Air circulation type with zero exhaust to the outside.



Built-in HEPA filter.
Replaceable by unit.

Code No.	Model No.	Power supply	Power consumption (W)	Current consumption (A)	Max air flow (m/min)	Max wind speed (m/s)	Noise level (dBA)	Weight (kg)	JAN (4907587)
623201	IPC-250CR	24VDC \pm 5%	108	4.5	1.5	25	74	22	019691

Accessory: Warning/Caution label sticker
Options: Pre-filter IPC-250CRPF, HEPA filter IPC-250CRHF, Needle electrode SDJ-05RH, Power adapter AD24-150-PD4

HAND TOOLS

INDUSTRIAL BITS

CONSTRUCTION BITS

RECIPROCATING SAW BLADES

ELECTRIC TOOLS

AIR TOOLS

AIR NIPPERS

STATIC SOLUTIONS

GASOLINE ENGINE TOOLS

LG-100/SG-100/GR-100

Conductive Rubber Mat

Stable conductive performance



We provide IEC standards-compatible ESD protection items ranging from EPA working mats laid on workbenches, storage racks, and trolley surfaces, EPA flooring for PVC floors or floor coating, and to wrist straps for ESD countermeasures.

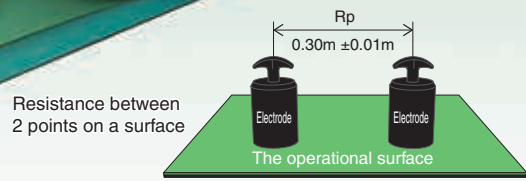
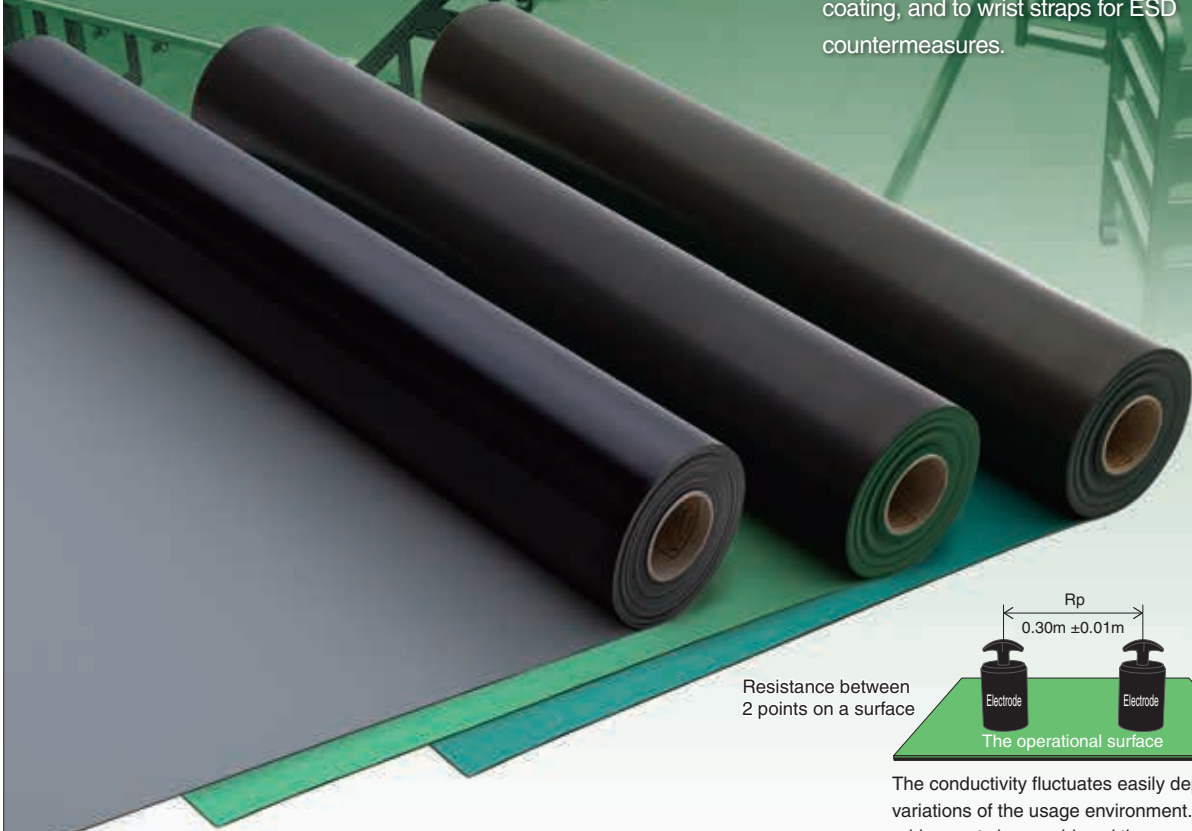

The conductivity fluctuates easily depending on humidity variations of the usage environment. Our conductive rubber mats have achieved the superior "conductive performance" compatible with the strict selection criteria.

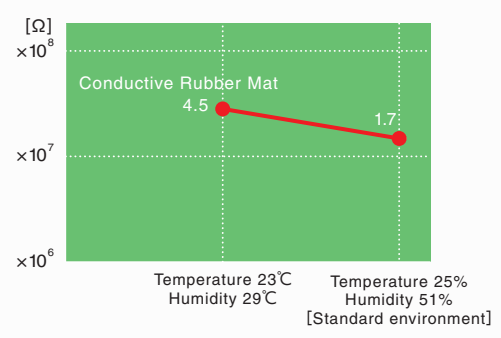

**LG-100/SG-100/GR-100 RoHS
Conductive Rubber Mat**

Special mats through our unique and strict conductivity standards within $10^7\Omega$. They maintain stable conductivity even if humidity and temperature change. Available in 3 colors: light green, green, and gray. A wide choice of accessories such as mat connecting gel and ground taps is also available.

HAND TOOLS
INDUSTRIAL BITS
CONSTRUCTION BITS
RECIPROCATING SAW BLADES
ELECTRIC TOOLS
AIR TOOLS
AIR NIPPERS
STATIC SOLUTIONS
GASOLINE ENGINE TOOLS

EPA Working Mat

Resistance value $10^6 \leq R \leq 10^7 \Omega$

Conductive Rubber Mat

For workbenches that require anti-static measures, such as semiconductors and electronic components.
Safe for soldering work. NBR material that does not melt under heat.

LG-100/SG-100/GR-100

- Uniform and stable conductive performance.
- Matte surface finish with low reflection and less fatigue on eyes. Moderate slipping and good workability.

RoHS

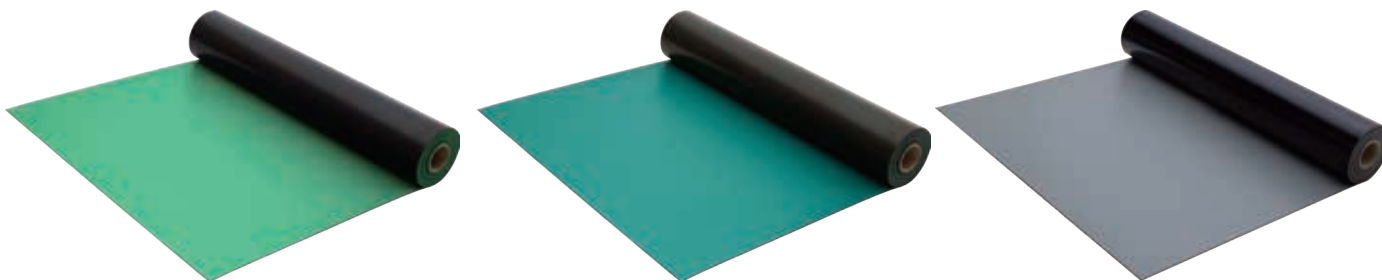

Code No.	Model No.	Color	Size (Length×Width×Thickness)	Weight	JAN (4907587)
621464	LG-100	Light green	10.0m×1.0m×2.0mm	29kg/roll	410368
621461	SG-100	Green	10.0m×1.0m×2.0mm	29kg/roll	410337
621490	GR-100	Gray	10.0m×1.0m×2.0mm	29kg/roll	032423

Please contact VESSEL for availability of other colors.
※Resistance value may vary depending on the conditions of the measurement environment such as the temperature and humidity.
Accessory: Sticker for conductive mat (5-pc set)

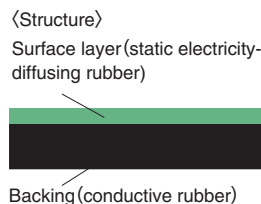

Sticker for conductive mat

LRH

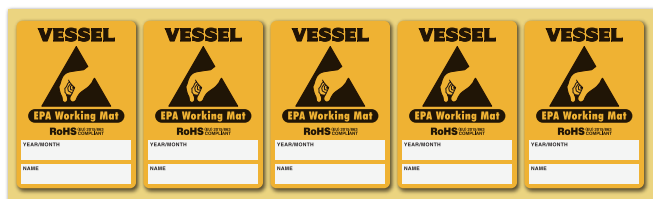

Code No.	Model No.	Quantity (pcs)	JAN (4907587)
806089	LRH-10S	10	008947
806090	LRH-100S	100	008954

ESD Mat Ground Kit

EPS-GK

- Conductive rubber mat can be easily and securely grounded.
- Rust-resistant snap, base plate, and screws, which are made of stainless steel.
- No adhesive part, so it can be reused when replacing the mats.

RoHS



Electricity flows smoothly.

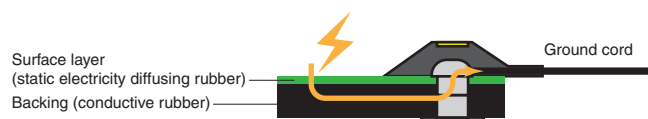

※Usable mat thickness:
The enclosed screw is for 2mm thickness mat. When using this kit with a mat of 3mm thickness or more, procure separately a small countersunk head screw M4.

Code No.	Model No.	Grounding cord (m)	Resistance value (Ω)	Inner Ctn. (set)	JAN (4907587)
621484	EPS-GK	2.4	1M (Built in the ground cord)	10	009968

HAND TOOLS
INDUSTRIAL BITS
CONSTRUCTION BITS
RECIPROCATING SAW BLADES
ELECTRIC TOOLS
AIR TOOLS
AIR NIPPERS
STATIC SOLUTIONS
GASOLINE ENGINE TOOLS

ESD Wrist Strap (10-pc Set) | EPS-05

- The elastic woven contractible band fits securely around the wrist.
- The buckle allows fine adjustment of the band size.
- The back side of the band is woven with conductive thread rubber. The front side is designed to be safe with no conductive parts.
- Ground cord has a 1MΩ current limiting resistor.
- Packaged in an antistatic bag.
- RoHS compliant(10 substances).
- Compliant with JIS C 61340-4-6:2016.



RoHS

Code No.	Model No.	Resistance value (Ω)	Length (m)	Inner Ctn. (set)	JAN (4907587)
621471	EPS-05	1M	Max. length of 2.5 (when contracted 0.72)	10	019660

Wrist Strap Cord | EPS-05-C

- Ground cord with 1MΩ current limiting resistor.
- Packaged in an antistatic bag.
- RoHS compliant(10 substances).
- Compliant with JIS C 61340-4-6:2016.



RoHS

Code No.	Model No.	Resistance value (Ω)	Length (m)	Contents (quantity)	JAN (4907587)
621472	EPS-05-C	1M	Max. length of 2.5 (when contracted 0.72)	10	019677

Ground Cord | EPC-18

- Designed to connect to a mat-connecting gel(includes a hook) or grounding tap.



Code No.	Model No.	Resistance value (Ω)	Length (m)	Contents (quantity)	JAN (4907587)
621393	EPC-18	1M	Max. length of 1.8 (when contracted 0.5)	20	410054

Accessory: 1 alligator clip

Conductive Anti-Fatigue Mat

- Conductive mats reduce foot fatigue from long hours of standing work.
- The surface is convex and non-slip. Can be used as a non-slip mat.
- Air pockets on the backside distribute the load and reduce foot and waist fatigue.
- Light gray color for easy visibility of dust and dirt.



AF-45

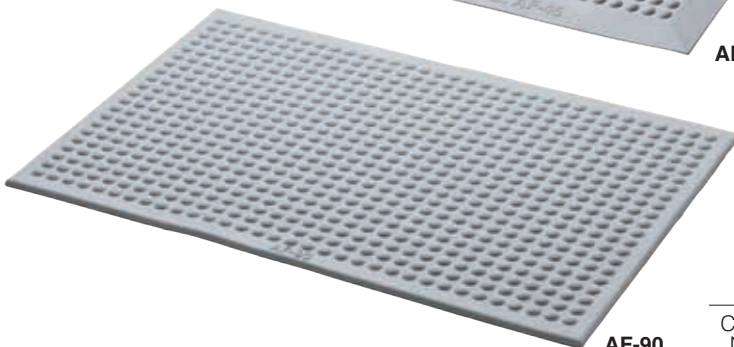

AF-90

| AF-45/AF-90

Resistance value $R \leq 1.0 \times 10^9 \Omega$

RoHS



Air pockets on the back surface distribute the load, to alleviate fatigue.



Code No.	Model No.	Color	Size (mm) Length×Width×Thickness	Resistance value (Ω)	Weight (kg)	JAN (4907587)
621489	AF-45	Gray	600×447×15	$R \leq 1.0 \times 10^9$	2.0	410566
621488	AF-90	Gray	900×600×15	$R \leq 1.0 \times 10^9$	4.2	410559

*Ground cord is not included.

HAND TOOLS
INDUSTRIAL BITS
CONSTRUCTION BITS
RECIPROCATING SAW BLADES
ELECTRIC TOOLS
AIR TOOLS
AIR NIPPERS
STATIC SOLUTIONS
GASOLINE ENGINE TOOLS

Electrostatic Field Meter | Eye-02

- Handy-type measuring instrument for the invisible electrostatic charge status and ion balance of ionizers.
- Maximum value(peak value)and Pause can be shown in the display.
- Incorporates an LED light of a cross mark as a guide to the correct measurement distance.
- Features a female thread for a camera screw, allowing measurements to be taken in a stable condition by mounting on a tripod or jig. A plate for the ion balance measurement is also included.
- The display has a backlight, making the screen easy to read even in the dark.
- Comes with a soft case for convenient carrying.
- Certificate of calibration can be issued.



Code No.	Model No.	Measurement range		Measuring distance
		Charged potential	Ion Balance	
621603	Eye-02	±0~±1.50kV (LO range) ±1.0~±22.0kV (HI range)	0~±220V	25mm±0.5mm (between charged object and the Eye-02)

Power source	Weight	JAN (4907587)
9VDC (006P battery 1pc.)	Main body: 170g Ion balance plate: 30g	020543

Accessories: Ion Balance Plate×1, Ground Cord w/alligator clip×1, Carrying Case×1, Strap×1

Surface Resistance Checker | SRC-01

- Instrument for easy measurement of surface resistance on floors, mats, desks, and chairs.
- Press and hold the measurement button switch, and the measured value will appear on the display. Equipped with an automatic power off function.
- A wide range of resistance values can be measured by switching the voltage.
- Can measure temperature/humidity as well as surface resistance.
- Includes probes to measure point-to-point resistance, ground-to-ground resistance, and volume resistance.
- Comes with a carrying case in which everything needed for measurement can be stored.
- Calibration certificate can be issued.

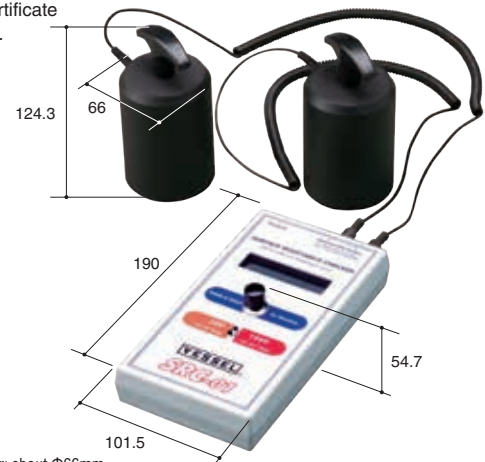

- Accessories:
- Probe (outer diameter: about Φ66mm, about 2.3 kg): 2
 - Curled cord for a body grounding (banana plugs at both ends): 1
 - Curled cord for measurement for the point-to-point resistance and resistance to ground (banana plug/mono plug): 2
 - Crocodile clip: 1
 - Large crocodile clip: 1
 - Stainless plate (185mm×100mm): 1
 - Carrying case: 1
 - 9V battery (006P type: manganese dry battery): 1
 - Manuals

Code No.	Model No.	Measurement standard	Measurement range	Applied voltage
621604	SRC-01	IEC61340-4-1 JIS-C2170	10 ³ ~10 ¹² Ω (Ω/sq)	10V (R<1.0×10 ⁶ Ω or Ω/sq) 100V (R≥1.0×10 ⁶ Ω or Ω/sq)

Power source	Weight	JAN (4907587)
9VDC (006P battery 1pc.)	Main body: Approx. 340g (including battery) Total weight: Approx. 6.2kg (including carrying case)	020505

※ The enclosed battery is a sample and may be out of use before the estimated number of use. Replace with a new one in this case.
※ Calibration certificate can be issued as option (payable).

ONE POINT | Eye-02

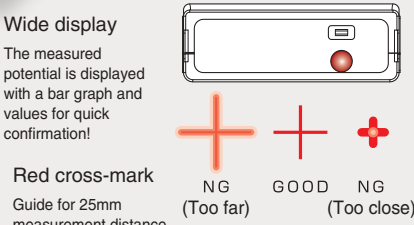
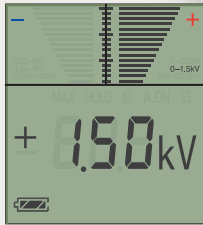
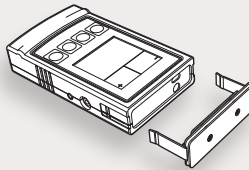

ONE POINT | SRC-01

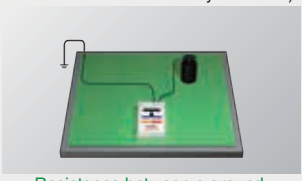

EPA Floor Sheet

Conductive Vinyl Floor Sheet CD-leum/CD-leum R

Resistance value $10^6 \sim 10^7 \Omega$

Vinyl floor sheet with uniform and consistent anti-static performance. Optimal for locations where static electricity is especially harmful, such as semi-conductor plants and clean rooms. **CD/CDR**



- Uniform and consistent conductive performance.
- Using a dedicated welding rod, the floor can be laid seamlessly.
- Dust-resistant surface facilitates cleaning and maintenance.
- High level of chemical resistance to acids, alkaline substances, disinfectants, etc.

RoHS

(CD-leum R only)

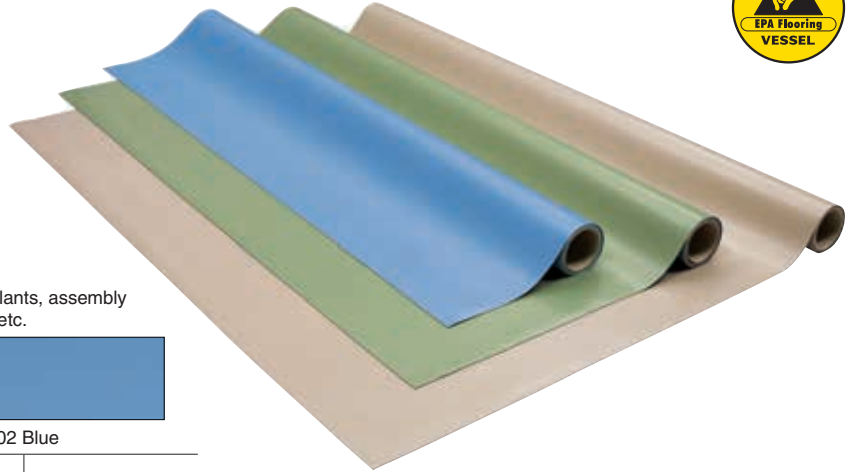

•Optimal for clean rooms in semi-conductor plants, electronics plants, assembly plants, and pharmaceutical plants, or hospitals, sterile rooms., etc.



CD-134 Beige

CD-138 Green

CD-602 Blue

Code No.	Model No.	Color	Size (Length×Width×Thickness)	Weight
621492	CD-134	Beige	9.0m×1.82m×2.0mm	3.1kg/m ² 51kg/roll
621493	CD-138	Green		
621491	CD-602	Blue		
621503	CDR-134	Beige	9.0m×1.82m×2.0mm	3.2kg/m ² 52kg/roll
621504	CDR-138	Green		
621505	CDR-602	Blue		

Optional: earth plate/welding rod. If you would like to have colors other than the above, please contact us.

※Resistance value may vary depending on the conditions of the measurement environment such as the temperature and humidity.

〈Structure〉

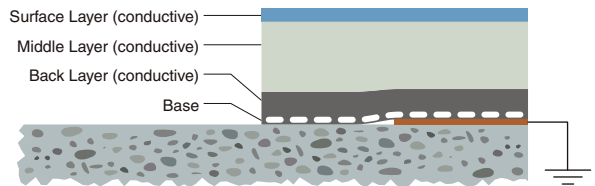

Anti-Static Vinyl Floor Sheet Lonstack/Lonstack R

Resistance value $10^8 \Omega$

Vinyl floor sheet with uniform and consistent anti-static performance. This prevents static electricity from being generated, resulting in prevention of adhesion of dust and device malfunction. **LS/LSR**



- Uniform and consistent conductive performance.
- Using a dedicated welding wand, the floor can be laid seamlessly.
- Dust-resistant surface facilitates cleaning and maintenance.
- High level of chemical resistance to acids, alkaline substances, disinfectants, etc.

RoHS

(Lonstack R only)



•Optimal for electronics assembly plants, computer rooms, computer rooms of banks, etc.



LS-134 Beige

LS-138 Green

LS-5602 Blue (Marble)

Code No.	Model No.	Color	Size (Length×Width×Thickness)	Weight
621495	LS-134	Beige	9.0m×1.82m×2.0mm	3.2kg/m ² 52kg/roll
621496	LS-138	Green		
621494	LS-5602	Blue (Marble)		
621501	LSR-134	Beige	9.0m×1.82m×2.0mm	3.0kg/m ² 50kg/roll
621502	LSR-138	Green		

Optional: earth plate/welding wand. If you would like to have colors other than the above, please contact us.

※Resistance value may vary depending on the conditions of the measurement environment such as the temperature and humidity.

〈Structure〉

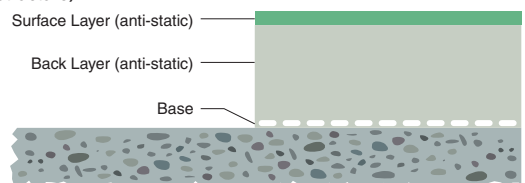

CW-900B

Clean Walker

Washing & drying restores adhesiveness.

No more film removal required. Sticky mat using the self-adhesion of high-quality urethane gel. When placed on indoor floors, such as at clean room entrances, it can firmly collect dust from shoe soles and cart wheels.

CW-900B
Clean Walker

RoHS

This product is a sticky mat that utilizes the self-adherence property of urethane gel.

It flexibly changes its shape against dents and projections of shoe soles and wheels of carts, collecting grit and dust well.

Dirt can be removed by washing with water.

Clean Walker

For indoor use only (for example, entrance to a clean room). Urethane gel adheres to shoe soles and catches dusts.

CW-900B

- High elasticity mat of 5 mm thick. Catches dust on shoes soles.
- Dust adhered on the CW-900B can be easily taken off by wiping with a damp cloth.
- Reversible(both sides can be used); running costs can be reduced.
- Indoor use only(most recommended to use at an entrance to a clean room)

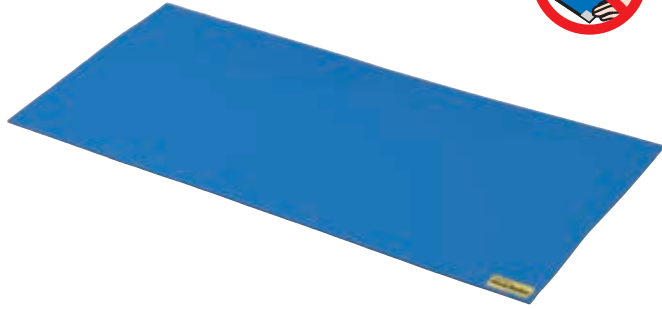

If the surface gets contaminated, simply wipe it with a damp cloth.

Code No.	Model No.	Color	Conductivity	Size (mm) (Length×Width×Thickness)	Weight (kg)	JAN (4907587)
621485	CW-900B	Blue	Insulator	500×900×5	2.4 (1pc.)	410528

ONE POINT

Clean Walker

It is an adhesive mat that applies the self-adhesive properties of urethane gel. It deforms flexibly along with the unevenness of shoes soles or trolley wheels; dust is reliably captured. Dust and contamination can be washed off with water.

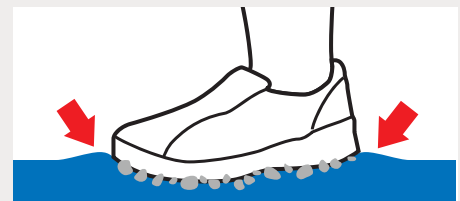

Applications

Ideal for removing dust off shoes soles or cleaning trolley wheels indoor

CW-900B

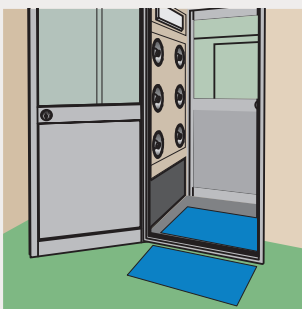



















Air shower booths



Inside the plant

 Read the instruction manual before using, and follow the instructions when using.

<p>HAND TOOLS</p> <p>Hand Tools</p> 	<p>https://www.vessel.co.jp/english/support/safety/handtools.html</p> <ul style="list-style-type: none"> • Always wear protective goggles when working with the product. • Do not use the product if any abnormality such as cracks, chipping, abrasion, or deformation is found. • Make sure of the applications, size, and usage that are suitable for the product before use. • Do not use the product in place of a hammer, crowbar, or lever. • Do not use the product in which electricity is running. • Do not modify the product. 
<p>INDUSTRIAL BITS</p> <p>Industrial Bits</p> 	<p>https://www.vessel.co.jp/english/support/safety/bit.html</p> <ul style="list-style-type: none"> • Read the instruction manual of the power tool carefully before use. • Always wear protective goggles when working with the product. • Be sure to shut off the power source before mounting or replacing bits. • Do not use the product if any abnormality such as cracks, chipping, abrasion, or deformation is found. • Never attempt to operate the power tool at no-load with the product attached. • Do not use the product in which electricity is running. • Do not modify the product. 
<p>CONSTRUCTION BITS</p> <p>Construction Bits</p> 	<p>https://www.vessel.co.jp/english/support/safety/bit.html</p> <ul style="list-style-type: none"> • Read the instruction manual of the power tool carefully before use. • Always wear protective goggles when working with the product. • Be sure to shut off the power source before mounting or replacing bits. • Do not use the product if any abnormality such as cracks, chipping, abrasion, or deformation is found. • Never attempt to operate the power tool at no-load with the product attached. • Do not use the product in which electricity is running. • Do not modify the product. 
<p>RECIPROCATING SAW BLADES</p> <p>Reciprocating Saw Blades</p> 	<p>https://www.vessel.co.jp/english/support/safety/saw_blades.html</p> <ul style="list-style-type: none"> • Check the applications and capabilities of the blade. • Read the instruction manual of the power tool carefully. • Always shut off the power source when replacing blades. • Before use, make sure that the blade is not loosely mounted. • Do not overload the product as this may cause damage to the blade. • Do not touch the blade just after stopping to use because they are hot. • Wear protective goggles and gloves when using the product. • Stop using the product if any abnormality is found. 
<p>ELECTRIC TOOLS</p> <p>Electric Tools</p> 	<p>https://www.vessel.co.jp/english/support/safety/electric.html</p> <ul style="list-style-type: none"> • Always wear protective goggles when working with the product. • Be sure to shut off the power source before mounting or replacing the tip tools. • Be sure to use a tip tool for power tools. • Do not use the product if any abnormality such as cracks, chipping, abrasion, or deformation is found. • Never attempt to operate the product at no-load with a tip tool mounted on the product. • Do not use the product in which electricity is running. • Do not disassemble or modify the product. 
<p>AIR TOOLS</p> <p>Air Tools</p> 	<p>https://www.vessel.co.jp/english/support/safety/airtools.html</p> <ul style="list-style-type: none"> • Use protective items such as a helmet, safety glasses, earplugs, dust mask, safety shoes, and others, depending on the work. • When installing or replacing the tip tools, be sure to shut off the air supply source. • Be sure to use a tip tool for power tools. • Do not use the product if any abnormality such as cracks, chipping, abrasion, or deformation is found. • Never attempt to operate the product at no-load with a tip tool mounted on the product. • Do not use the product in which electricity is running. • Do not modify the product. 
<p>AIR NIPPERS</p> <p>Air Nippers</p> 	<p>https://www.vessel.co.jp/english/support/safety/airnipper.html</p> <ul style="list-style-type: none"> • Do not touch the blade. • Always wear protective goggles and earplugs when working with the product. • When installing or replacing blades or the nipper, be sure to shut off the power source. • Do not use the product if any abnormality such as cracks, chipping, abrasion, or deformation is found. • Do not use the product in which electricity is running. • The product may cause vibration. • Do not modify the product. 
<p>STATIC SOLUTIONS</p> <p>Static Solutions</p> 	<p>https://www.vessel.co.jp/english/support/safety/staticelectric.html</p> <ul style="list-style-type: none"> • Do not use the product in the environments requiring the explosion-proof measures. • Do not use the product in an atmosphere containing flammable or combustible substances. • Do not use the product in an environment subject to rapid temperature changes or where condensation occurs. • Do not use the product in a place where it is exposed to water, solvents, oil, etc. or in a humid place. • Do not use the product with the power supply standard or the air pressure other than those specified in the specifications. • Do not disassemble or modify the product. 
<p>GASOLINE ENGINE TOOLS</p> <p>Gasoline Engine Tools</p> 	<p>https://www.vessel.co.jp/english/support/safety/gasolineengine.html</p> <ul style="list-style-type: none"> • In case any crack, chip, or deformation is observed, stop using the unit immediately. • Do not use the unit or fill fuel in presence of flame or spark. • Make sure to use two cycle oil with gasoline at mixture ratio of 1:25. • The unit emit vibration, heat and exhaust fumes. • Always wear eye, head and ear protectors when using this tool. 



บริษัท นานตีอินเตอร์เทรด จำกัด
NANDEE INTER-TRADE CO., LTD.

314,316,318,320,322 ซอยจันทน์ 32 ถนนจันทน์ แขวงทุ่งวัดดอน เขตสาทร กทม. 10120

-  : 0-2675-8239
-  : @nandeeintertrade
-  : nandeeintertrade
-  : www.nandee.co.th
-  : marketing@nandee.co.th
sales@nandee.co.th