

# CUPLA

Quick Connect Couplings

# REFRIGERATION, AUTOMOTIVE & AIR CONDITIONING CUPLA SERIES

GENERAL CATALOG



# Cuplas Enable Flexible, Fast, and Secure Connections for Various Fluid Lines.

Nitto Kohki's unique technologies and dedicated research have been proven by numerous patents, which led to the development of 25,000 different Cupla variations.

- Diverse applications from general household to high-tech industries such as in oceanic and space development.
- Numerous sizes are available for various needs.
- Wide varieties of body materials such as steel, brass, plastic, aluminum or stainless steel are available.



**For easy replacements:**

*Replacements of pneumatic / hydraulic tools, pneumatic / hydraulic cylinders, mold attachments, etc.*

**For temporary installation in test line:**

*Vacuum tests, pressure durability tests, leakage tests, running tests, etc.*

**For filling:**

*For filling up various industrial gases, including inert gases, nitrogen, LPG, carbon dioxide, oxygen, fuel gas, etc.*

**For maintenance services:**

*For computer cooling system, hydraulic cylinders in die-casting machines.*

**For transfer:**

*For transfer of solid items through pipes such as screws and nuts as well as for electric power cable lines.*

**As joints:**

*Applications other than fluid transfer covering connections for holding works while anchored or carried around.*

***A profusion of patented technology and recognition of high quality and high performance by global users.***

## ISO 9001 and 14001 Certification Award

"Cuplas" quick connect couplings are produced as the crystallization of high-grade know-how nurtured in the fields of fluid engineering and materials engineering, and top level precision machining technology. Having assessed Nitto Kohki consistent quality assurance and control system ranging from design and development through procurement of material, manufacture, assembly, and shipping, the Japan Quality Assurance Foundation, authority for inspection and registration, awarded us "ISO 9001", international standard for quality management systems, and "ISO 14001", international standard for environment management systems intended to perform global environment preservation and pollution control. High reliability built on unparalleled "high quality" and accumulated history of "productivity" for stable supply. Cupla is receiving overwhelming support from many users spread all over the world as the top brand for fluid energy transmission and control.



ISO 14001  
JQA-EM4057  
NITTO KOHKI CO.,LTD.



ISO 9001  
JQA-2025  
NITTO KOHKI CO.,LTD.  
Couplings Division

## **⚠ Beware of imitations**

Recently on the market, there have appeared similar products that invite misidentification or confusion with Nitto Kohki Cuplas, or such products that claim to have compatible mating parts. Nitto Kohki cannot accept responsibility for any accident that may result by mixed use with a coupling of another brand that seems connectable to a Nitto Kohki Cupla. Nitto Kohki Cuplas are produced with their own unique tolerances and precision under strict quality control, and are not interchangeable with other couplings that are not under such tolerances. Therefore, connection to other brand of coupling may end up with abrupt breakdown or personal injury. Please be sure to check for our marks below, which are always inscribed on Nitto Kohki Cupla products, when you order and purchase.



**Specifications to Be Checked When Selecting Cuplas**

<b>Fluid and the Temperature</b>	Select a Cupla with body and seal materials that suit the fluid and its temperature.	There are different body and seal materials to suit different fluids. For example, we recommend steel for air, and brass or stainless steel for water.
<b>Fluid Pressure</b>	Select a Cupla suitable for the actual max. fluid pressure.	Fluid pressure is also a key to Cupla selection. Each Cupla has a different structure to cope with each pressure resistance range.
<b>Automatic Shut-off Valve</b>	Select a Cupla with a valve structure that suits the piping application.	Valve combinations are two-way shut-off, one-way shut-off, or straight through types. Choose carefully. Unless it is a two-way shut-off type, the internal fluid will flow out from the Cupla when it is disconnected.
<b>Operating Environment</b>	Select a Cupla with design and materials that suit each operating environment.	In choosing the type of Cupla, body material and seal material, consider the temperature range, possible dirt and dust, and/or corrosive atmosphere in the operating environment.
<b>Size and Type of End Configurations</b>	Finally and critically specify the size and type of end configurations.	Having checked the type and materials for the Cupla, now specify the size and type of end configurations to suit the type of piping. Choose carefully, as the size affects the fluid flow rate.

Note: End configuration and size may be limited by the type of Cuplas.

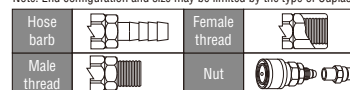

**Glossary**

**International System of Units (SI Units)**

Units stated in this catalog are based on SI Units. The old units, which are Non-SI Units, are also written within parentheses side by side with SI Units for reference only.

**Body Material**

Indicates the material that is used for the plug body or socket body that forms the flow path of fluid through the Cupla. Some products have internal components of a different material. Please check with us for details.

**Size**

Indicates the nominal size of the pipe thread connection or of the hose to be used.

**Working pressure**

The normal allowable fluid pressure under continuous use.

**Max. Tightening Torque**

Considering the balance between possible leakage caused by loose fit and too much structural stress when a Cupla is mounted on a workpiece, the appropriate screw-in torque value is suggested by the maker.

**Min. Cross-Sectional Area**

The minimum cross-sectional area of the fluid path when the Cupla is connected.

**Suitability for Vacuum**

Indicates if the Cupla has necessary performance required for vacuum applications. (Note that the required performance is different in connection and in disconnection.)

**Flow Direction**

The design of some Cuplas may restrict the fluid flow direction only to one way. Check the maker's suggested direction before installation.

**Interchangeability**

Indicates whether the Cupla plug and socket can be connected with each other.

**Working Temperature Range**

The minimum and maximum temperature, in-between which the Cupla with the seal material can be used. However, it does not mean that they can be used continuously at the minimum or maximum working temperatures. Please check with us if you need Cuplas in such extreme applications.

**Automatic Shutoff Valves**

The structure of valves that open on connection and shut on disconnection automatically.

**Pressure Loss**

The loss of pressure when fluid runs through the Cupla set.

**Seal Material**

This shows the material used to seal the Cupla, usually an O-ring.

**Properties of rubbers used for O-rings**

Seal material		Working Temperature Range	Features
Common name	Mark		
<b>Nitrile rubber</b>	NBR (SG)	-20°C to +80°C	Standard seal with excellent oil resistance.
<b>Hydrogenated nitrile rubber</b>	HNBR (H708)	-20°C to +120°C	Compared with the standard nitrile rubber, the seal material is more heat and weather resistant. In addition to these features, the seal material can also be used for refrigeration oil and refrigerant applications such as HFC-134a.
<b>Fluoro rubber</b>	FKM (X-100)	-20°C to +180°C	Excellent for heat, weather, and oil resistance. Applicable to wide range of applications.
<b>Chloroprene rubber</b>	CR (X-306)	-20°C to +80°C	Excellent weather resistance.
	CR (C308)	-20°C to +80°C	In addition to the above features, the seal material can also be used for refrigerant applications such as HFC-134a.

Note:

- Even among rubber materials of the same category, the working temperature range differs depending upon the design of the Cuplas. For details, see the specifications of each Cupla series. As for the Nitto symbol for rubber material, fluoro rubber is designated as "FKM" or "X-100" for example.
- The above are general features, but the seal resistance depends on fluid temperature, fluid concentration, and additives contained in the fluid.

**Green Procurement**

Nitto Kohki has made every effort in developing "Environmental Improvement Plans" through the implementation of ISO14001, to execute environmentally conscious business activities on a company-wide basis. As a part of our ongoing commitment to the environment, we are also committed to reduce and/or exclude restricted chemical substances from our products as designated by RoHS directives, laws and regulations of chemical substances in Japan.

For further details, please visit [www.nitto-kohki.co.jp/e/](http://www.nitto-kohki.co.jp/e/).



# Refrigerant Cupla Series

Contributes to charging and inspection work on refrigerators, air conditioners and automobile-related equipment.

For charging of air, nitrogen, refrigerant and refrigerant oil, and for vacuum suction and helium leak test

Name and Type	Outer Appearance	Body material	Size	Counterpart	Features / Applications	Page
For Vacuum Suction and Refrigerant Charging <b>SP-V Cupla</b>		Brass Stainless steel	Rc 1/4, Rc 3/8 Rc 1/2, Rc 3/4	SP-V	<ul style="list-style-type: none"> <li>For vacuum suction and refrigerant charging.</li> <li>Various seal materials available for wide variety of refrigerants.</li> </ul>	5 to 6
★ Double O-ring Version of SP-V Cupla <b>S-V-W Type</b>		Brass Stainless steel	Rc 1/4, Rc 3/8 Rc 1/2, Rc 3/4	2P-V, 3P-V 4P-V, 6P-V	<ul style="list-style-type: none"> <li>Employs a double O-ring sealing structure in the socket of SP-V Cupla.</li> <li>Employs double O-rings to improve airtightness and vacuum resistance when connected.</li> </ul>	6
★ Non-interchangeable with SP-V Cupla <b>SP-V-GN Cupla (SP-V-GNN Cupla)</b>		Brass Stainless steel	Rc 1/4, Rc 3/8 Rc 1/2, Rc 3/4	SP-V-GN (SP-V-GNN)	<ul style="list-style-type: none"> <li>Prevents an operator from mixing up different refrigerants.</li> <li>One groove is formed in the spanner surface to differentiate from the SP-V Cupla.</li> </ul>	7 to 8
★ Double O-ring Version of SP-V-GN Cupla <b>S-V-GN-W Type</b>		Brass Stainless steel	Rc 1/4, Rc 3/8 Rc 1/2, Rc 3/4	2P-V-GN, 3P-V-GN 4P-V-GN, 6P-V-GN	<ul style="list-style-type: none"> <li>Employs a double O-ring sealing structure in the socket of SP-V-GN Cupla.</li> <li>Employs double O-rings to improve airtightness and vacuum resistance when connected.</li> </ul>	8
For Connection to Straight Aluminum / Copper Pipe <b>PCV Pipe Cupla</b>		Brass	R 1/4, R 3/8	Copper pipe diameter 4 to 15.88 mm OD	<ul style="list-style-type: none"> <li>Can be connected/disconnected without pipe forming.</li> <li>Perfect for pressure resistance test, vacuum suction and refrigerant charging.</li> </ul>	9 to 10
★ For Connection to Straight Aluminum / Copper Pipe <b>Pipe Cupla PCVH Type</b>		Brass	R 1/4, R 3/8	Copper pipe diameter 4 to 15.88 mm OD	<ul style="list-style-type: none"> <li>Lever shape has been changed for smooth operation.</li> </ul>	11
★ Triple Seal Version of PCV Pipe Cupla <b>PCV-W Type</b>		Brass	R 1/4, R 3/8	Copper pipe diameter 4 to 15.88 mm OD	<ul style="list-style-type: none"> <li>A triple seal structure is employed, one at the end of pipe and two on the outside of pipe.</li> <li>Highly effective for airtightness and vacuum holding.</li> </ul>	11
★ For Connection to Male Thread <b>Screw Cupla PCS Type</b>		Steel (Partly stainless steel and brass)	R 1/4, R 3/8	7/16 to 1 1/16UNF	<ul style="list-style-type: none"> <li>By pushing the Screw Cupla direct to the male thread for connection improves operating efficiency.</li> <li>Built-in ball lock sleeve prevents accidental disconnection, ensuring safe operation.</li> </ul>	12
★ High Pressure Version of Screw Cupla PCS Type <b>PCS-HP Type</b>		Steel (Partly stainless steel and brass)	R 1/4, R 3/8	7/16 to 1 1/16UNF	<ul style="list-style-type: none"> <li>Suits for refrigerants that require high pressure.</li> </ul>	12
★ For Charging Industrial Gases and Refrigerants <b>Charge Cupla CS Type</b>		Stainless steel (Partly aluminum and brass)	Rc 1/4	2P-V, 3P-V	<ul style="list-style-type: none"> <li>Connects to the standard 2P-V and 3P-V Plugs.</li> <li>Can be connected or disconnected even when the residual pressure remains.</li> </ul>	13
★ High Pressure Version of Charge Cupla CS Type <b>Charge Cupla CS-HP Type</b>		Stainless steel (Partly aluminum and brass)	Rc 1/4, Rc 1/2	2P-V, 3P-V 4P-V	<ul style="list-style-type: none"> <li>Suits for refrigerants that require high pressure.</li> </ul>	14
★ For Charging Industrial Gases and Refrigerants (With Purge Function) <b>Charge Cupla CNR Type / LRP Type</b>		Stainless steel (Partly aluminum and brass)	Rc 1/4, Rc 3/8 Rc 1/2	2P-V, 3P-V 4P-V	<ul style="list-style-type: none"> <li>Can be connected or disconnected even when the residual pressure remains.</li> <li>Lifting the lever discharges the residual pressure for easy disconnection of the plug.</li> </ul>	15
★ For Charging Industrial Gases and Refrigerants <b>Airless Charge Cupla CNA Type</b>		Stainless steel (Partly aluminum and brass)	Rc 3/8	CNA-3P-V	<ul style="list-style-type: none"> <li>An automatic airless valve minimizes admixture volume of air on connection and fluid spillage on disconnection.</li> </ul>	16
★ For Automatic Plug Disconnection <b>Auto Cupla ACV Type</b>		Stainless steel (Partly aluminum and brass)	Rc 1/4, Rc 3/8	2P-V, 3P-V	<ul style="list-style-type: none"> <li>Connects to the standard 2P-V and 3P-V Plugs.</li> <li>Disconnects the plug with air-driven mechanism.</li> </ul>	17
★ High Pressure Version of Auto Cupla ACV Type <b>Auto Cupla ACV-HP Type</b>		Stainless steel (Partly aluminum and brass)	Rc 1/4, Rc 3/8	2P-V, 3P-V	<ul style="list-style-type: none"> <li>Suits for refrigerants that require high pressure.</li> </ul>	18
★ For Automatic Valve Opening / Closing and Plug Connection / Disconnection <b>Auto Cupla AC Type (ACS Type)</b>		Stainless steel (Partly aluminum and brass)	Rc 1/4, Rc 3/8	2P-V, 3P-V	<ul style="list-style-type: none"> <li>Connects to the standard 2P-V and 3P-V Plugs.</li> <li>Air-driven mechanism is employed to connect and disconnect the plug and to open and close the valve.</li> </ul>	19
★ High Pressure Version of Auto Cupla AC Type <b>Auto Cupla AC-HP Type</b>		Stainless steel (Partly aluminum and brass)	Rc 3/8	3P-V	<ul style="list-style-type: none"> <li>Suits for refrigerants that require high pressure.</li> </ul>	20
★ Screw-on Type Cupla <b>Screw Cupla NCF Type</b>		Stainless steel	R 1/4, R 3/8	7/16 to 1 1/16UNF	<ul style="list-style-type: none"> <li>Screws on to the male unified thread easily.</li> <li>Employs a three-terraced-shape lip packing as a seal material.</li> </ul>	21

# Pipe Cupla Series

Directly connects with any type of pipe end configurations.

**⚠ Caution for Custom-made Cuplas**

Custom-made Cuplas are products designed and produced based on the specifications presented by the customer. Prior to actual production, technical documentation presented by us (drawings, specification sheets, etc.) shall be exchanged and approved by the customer. For the use of the product, the customer shall check the safety and the full compatibility with the equipment used by evaluating its performance thoroughly, under actual operating conditions. We shall in no case be liable for any loss or damage if the Cupla is used outside the conditions and specifications set out in the original technical documentation.

Name and Type	Outer Appearance	Body material	Size	Counterpart	Features / Applications	Page
★ Equipped with Special Chuck Lock System for Expanded Pipes and Bulged Pipes <b>Pipe Cupla PCHS Type</b>		Stainless steel	Specified by a customer	Based on customer's pipe size dimensions	• Employs a special chuck lock system to reduce lock scratches and improve pressure resistance.	23
★ For Expanded Pipes <b>Pipe Cupla PCB Type</b>		Brass Stainless steel	Specified by a customer	Based on customer's pipe size dimensions	• Employs a ball lock system to grip on the outer surface of pipe.	23
★ For Bulged Pipes and Spool Pipes <b>Pipe Cupla PCBW Type</b>		Brass Stainless steel	Specified by a customer	Based on customer's pipe size dimensions	• Employs a double-row ball lock system to grip on the outer surface of pipe securely.	24
★ For Bulged Pipes and Spool Pipes <b>Pipe Cupla PCP Type</b>		Plastic (Partly stainless steel)	Specified by a customer	Based on customer's pipe size dimensions	• Employs plastic chucks that scarcely scratches pipes.	24
★ For Straight Pipes <b>Pipe Cupla PCBL Type</b>		Stainless steel (Partly aluminum and brass)	Specified by a customer	Based on customer's pipe size dimensions	• Employs a ball lock system to grip on the outer surface of pipe. Improved connection and disconnection with lever operation.	25
★ For Straight Pipes <b>Pipe Cupla PCLB Type</b>		Brass (Partly steel)	Specified by a customer	Based on customer's pipe size dimensions	• Employs a ball lock system to grip on the outer surface of pipe. Improved connection and disconnection with lever operation.	25
★ For Straight Pipes <b>PCV Pipe Cupla with Residual Pressure Release Device</b>		Brass (Partly stainless steel and steel)	Specified by a customer	Based on customer's pipe size dimensions	• Combination of PCV Pipe Cupla and the residual pressure release device for easy disconnection. • Raising the lever of the residual pressure release device discharges the residual pressure for easy pipe disconnection.	26
★ For Pipes with Fittings <b>Pipe Cupla PCB Type</b>		Brass Stainless steel	Specified by a customer	Based on customer's pipe size dimensions	• Suits for connection and disconnection with pipe fittings. A ball lock system grips on the rear of the hex. nut of pipe fitting upon connection.	26
★ For Straight Pipes and Pipes with Blind Rubber Plugs <b>Pipe Cupla PCW Type</b>		Brass (Partly stainless steel and steel)	Specified by a customer	Based on customer's pipe size dimensions	• Unique lock design on pipes allows some slight variations in pipe dimensions.	27
★ For Large Diameter Straight Pipes <b>Pipe Cupla PCA Type</b>		Stainless steel (Partly steel)	Specified by a customer	Based on customer's pipe size dimensions	• Suits for connection and disconnection with large diameter straight pipes.	27
★ For Special Pipes <b>Pipe Cupla PCD Type</b>		Stainless steel (Partly aluminum)	Specified by a customer	Based on customer's work size dimensions	• Suits for connection and disconnection with pipe fittings.	28
★ High Pressure Type for Spool Pipes <b>Pipe Cupla PCH Type</b>		Stainless steel	Specified by a customer	Based on customer's pipe size dimensions	• A special chuck lock system is employed to reduce lock scratches and improve pressure resistance.	28
★ For connecting directly to the female thread <b>Screw Cupla PCSI Type</b>		Stainless steel (Partly aluminum)	Specified by a customer	Based on customer's thread size dimensions	• By pushing the Screw Cupla direct to the female thread for connection improves operating efficiency.	29
★ For Locking at the Leading End of Workpiece from the Inside <b>Pipe Cupla PCBI Type</b>		Stainless steel (Partly aluminum)	Specified by a customer	Based on customer's work size dimensions	• Employs balls to lock at the leading end of workpiece from the inside.	29
★ For Locking at the Leading End of Workpiece from the Inside <b>Pipe Cupla PCI Type</b>		Stainless steel (Partly aluminum and steel)	Specified by a customer	Based on customer's work size dimensions	• Employs chucks to lock at the leading end of workpiece from the inside.	30
★ For Pipe Inner Wall Lock <b>Pipe Cupla PCIF Type</b>		Stainless steel	Specified by a customer	Based on customer's pipe size dimensions	• Employs chucks to grip on the inner wall of pipe. Suitable for applications with a small amount of clearance.	30
★ For Automatic Pipe Disconnection <b>Auto Cupla APCB Type</b>		Stainless steel	Specified by a customer	Based on customer's pipe size dimensions	• Air-driven mechanism is employed in the Auto Cupla to disconnect the pipe automatically.	31
★ For Refrigerant Charge Valves Used in Car Air Conditioner Production Lines <b>PCB Type Cupla for Charge Valves</b>		Brass (Partly stainless steel)	Specified by a customer	Refrigerant charge valves used in car air conditioner production lines	• Quick connection and disconnection with refrigerant charge valves used in car air conditioner production lines.	31

**Note:** Products with an asterisk (★) are made-to-order items. Please contact us for details.

For Charging Refrigerant, Helium Gas and Vacuum Suction

# SP-V Cupla

## Cupla with a built-in automatic shut-off valve for charging refrigerant, helium gas and vacuum suction.

Excellent sealing structure with a built-in automatic shut-off valve developed for charging refrigerant and vacuum suction. Both socket and plug are completely sealed when disconnected withstanding up to vacuum of  $1.3 \times 10^{-1}$  Pa ( $1 \times 10^{-3}$  mm Hg). Various body and seal materials are available for the production of air-conditioning units, refrigerators and package air-con. (refrigerant charging, vacuum suction and leak test)

### Seal Materials for Refrigerants

Various eco-friendly refrigerants for air conditioner and refrigerator have been developed. Nitto Kohki, having invested years in the research and development of excellent seal materials to withstand refrigerants and refrigerant oils, has made early attempts to develop and manufacture the seal materials for these eco-friendly refrigerants.

	Seal material	
	Hydrogenated nitrile rubber	Chloroprene rubber
Mark	HNBR (H708)	CR (C308)
Features	Resistant to hydrofluorocarbons (HFC-134a, HFC-407C, HFC-410A, HFC-404A), and PAG type and ester type oils. Also resistant to heat up to 120°C.	Excellent resistance to hydrochlorofluorocarbons (HCFC-22 and HFC-134a).
Application	Refrigerator production lines Air conditioner production lines	Air conditioner production lines

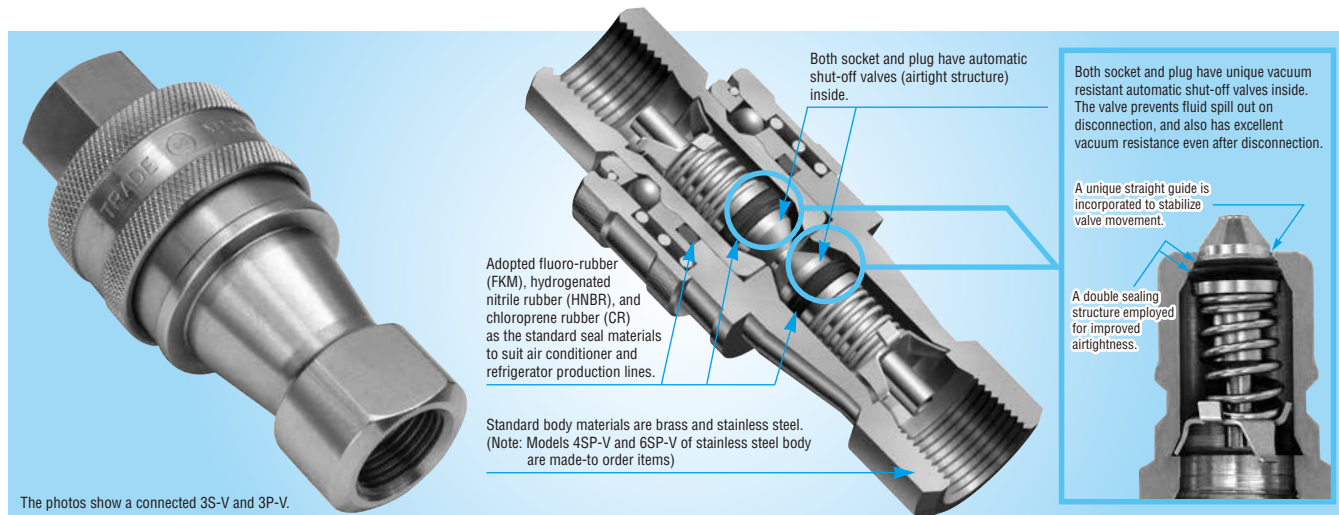

### Specifications

Body material	Brass (Standard material)		Stainless steel (Standard material)	Stainless steel (Made-to-order item)
Size (Thread)	1/4", 3/8"	1/2", 3/4"	1/4", 3/8"	1/2", 3/4"
Working pressure	MPa	5.0	3.0	7.5
	kgf/cm <sup>2</sup>	51	31	76
	bar	50	30	75
	PSI	725	435	1090
Seal material	Seal material	Mark	Working temperature range	Remarks
	Chloroprene rubber	CR (C308)	-20°C to +80°C	Standard material
	Fluoro rubber	FKM (X-100)	-20°C to +180°C	
	Hydrogenated nitrile rubber	HNBR (H708)	-20°C to +120°C	

### Max. Tightening Torque (Nm {kgf-cm})

Size (Thread)	1/4"	3/8"	1/2"	3/4"
Torque	Brass	9 {92}	12 {122}	30 {306}
	Stainless steel	14 {143}	22 {224}	60 {612}

### Min. Cross-Sectional Area (mm<sup>2</sup>)

Model	2SP-V	3SP-V	4SP-V	6SP-V
Min. cross-sectional area	18	38	71	110

### Suitability for Vacuum ( $1.3 \times 10^{-1}$ Pa { $1 \times 10^{-3}$ mmHg})

Socket only	Plug only	When connected
Operational	Operational	Operational

### Admixture of Air on Connection (mL)

Model	2SP-V	3SP-V	4SP-V	6SP-V
Volume of air admixture	1.0	2.4	3.2	10.5

### Flow Direction

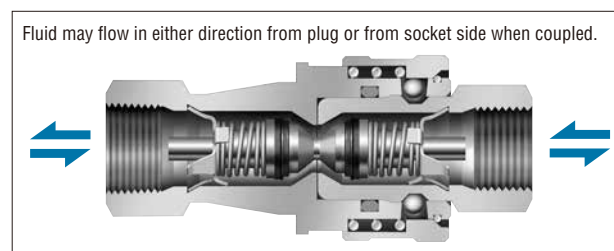

### Interchangeability

Socket and plug with different sizes cannot be connected to each other. Interchangeable with SP Cupla Type A but take heed of flow rate reduction.

### Flow Rate – Pressure Loss Characteristics

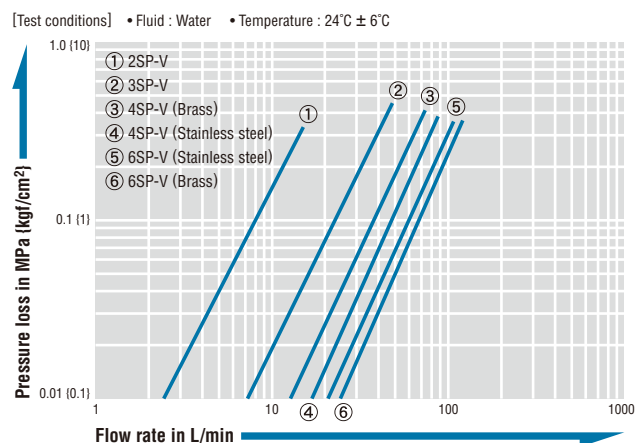

**Models and Dimensions** (WAF : WAF stands for width across flats.)

**Socket**

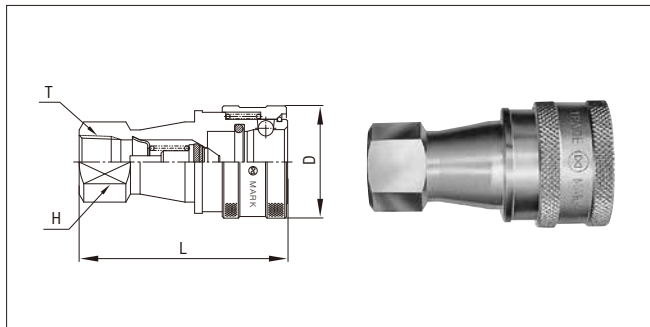

Model	Application	Mass (g)		Dimensions (mm)			
		Brass	Stainless steel	L	øD	H (WAF)	T
2S-V	R 1/4	136	127	58	28	19	Rc 1/4
3S-V	R 3/8	217	197	65	35	21	Rc 3/8
4S-V	R 1/2	421	393	72	45	29	Rc 1/2
6S-V	R 3/4	709	658	88	55	35	Rc 3/4

**Plug**

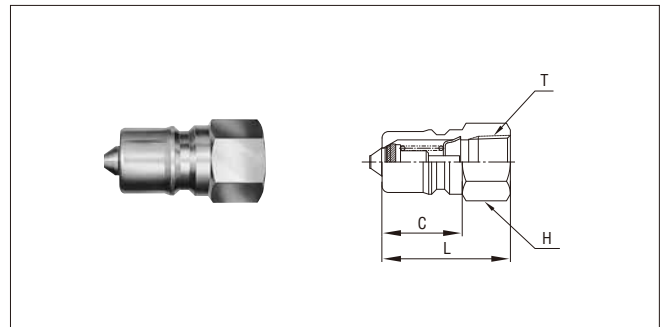

Model	Application	Mass (g)		Dimensions (mm)			
		Brass	Stainless steel	L	H (WAF)	C	T
2P-V	R 1/4	39	34	36	Hex. 17	22	Rc 1/4
3P-V	R 3/8	67	59	40	Hex. 21	25	Rc 3/8
4P-V	R 1/2	123	118	44	Hex. 29	28	Rc 1/2
6P-V	R 3/4	211	202	52	Hex. 35	36	Rc 3/4

**Application Example**



**Double O-ring Version of SP-V Cupla**

**SP-V Cupla S-V-W Type**

Employs a double O-ring sealing structure to suit high airtightness. Highly effective in airtightness and vacuum resistance when connected!

**Specifications**

The same specifications as the SP-V Cupla. See the SP-V Cupla specifications.

**Dimensions**

The same dimensions as the SP-V Cupla. See the SP-V Cupla dimensions.

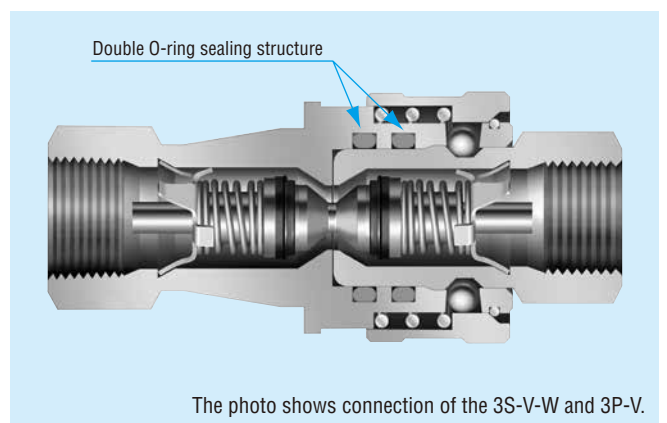

Model	Application
2S-V-W	R 1/4
3S-V-W	R 3/8
4S-V-W	R 1/2
6S-V-W	R 3/4

Note: No lubricant is applied to HNBR O-ring in the socket. Please apply refrigerant oil to O-ring before use.

Non-interchangeable with SP-V Cupla

# SP-V-GN Cupla

Prevents an operator from mixing up different refrigerants.

It may cause damage to equipment or products if different refrigeration oils are mixed together.

- There is no interchangeability between SP-V Cupla and SP-V-GN Cupla to prevent accidental misconnection.
- A socket of SP-V-GN Cupla has a different shape from that of SP-V Cupla and has a groove on the body. A plug of SP-V-GN Cupla also has a groove on the Nut to be distinguished from SP-V Cupla.

## Comparison of External Appearance

X indicates non-interchangeability.

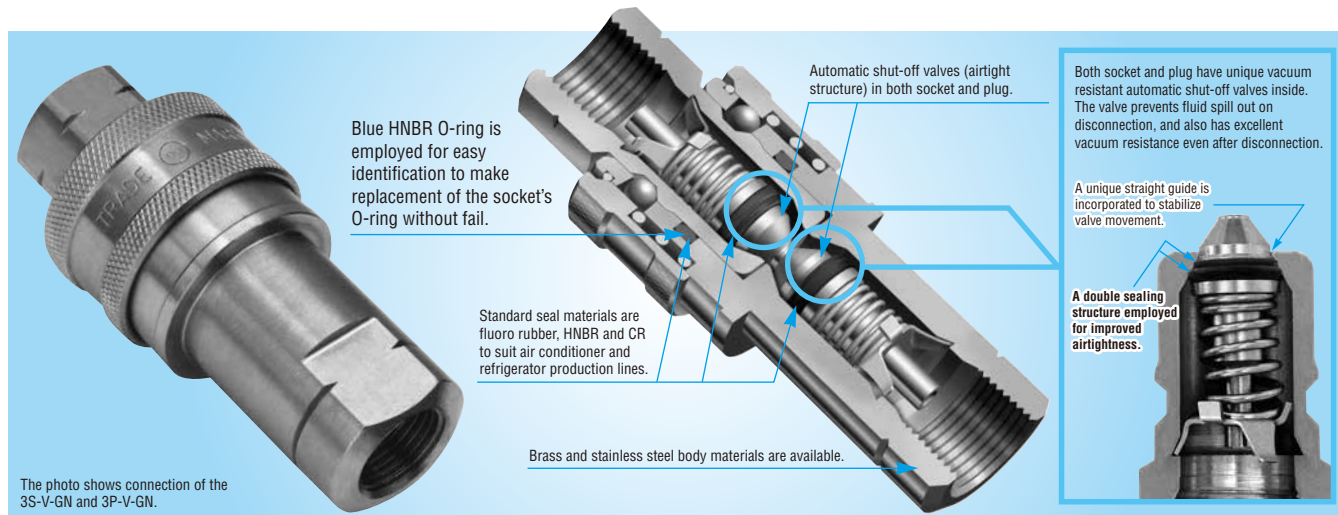
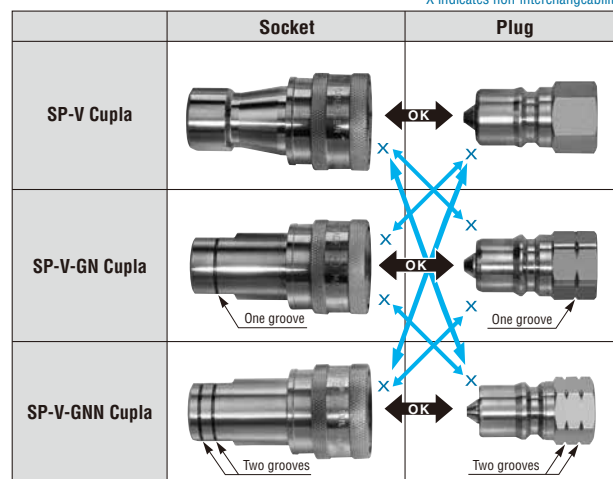

## Specifications

Body material		Brass		Stainless steel	
Size (Thread)		1/4", 3/8"	1/2", 3/4"	1/4", 3/8"	1/2", 3/4"
Working pressure	MPa	5.0	3.0	7.5	4.5
	kgf/cm <sup>2</sup>	51	31	76	46
	bar	50	30	75	45
	PSI	725	435	1090	653
Seal material Working temperature range	Seal material	Mark	Working temperature range	Remarks	
	Chloroprene rubber	CR (C308)	-20°C to +80°C	Standard material	
	Fluoro rubber	FKM (X-100)	-20°C to +180°C		
	Hydrogenated nitrile rubber	HNBR (H708)	-20°C to +120°C		

## Max. Tightening Torque (Nm {kgf-cm})

Size (Thread)		1/4"	3/8"	1/2"	3/4"
Torque	Brass	9 {92}	12 {122}	30 {306}	50 {510}
	Stainless steel	14 {143}	22 {224}	60 {612}	90 {918}

## Min. Cross-Sectional Area (mm<sup>2</sup>)

Model	2SP-V-GN	3SP-V-GN	4SP-V-GN	6SP-V-GN
Min. cross-sectional area	18	38	71	110

## Suitability for Vacuum (1.3 × 10<sup>-1</sup> Pa {1 × 10<sup>-3</sup> mmHg})

Socket only	Plug only	When connected
Operational	Operational	Operational

## Admixture of Air on Connection (mL)

Model	2SP-V-GN	3SP-V-GN	4SP-V-GN	6SP-V-GN
Volume of air admixture	1.0	2.4	3.2	10.5

## Flow Direction

Fluid may flow in either direction from plug or from socket side when coupled.

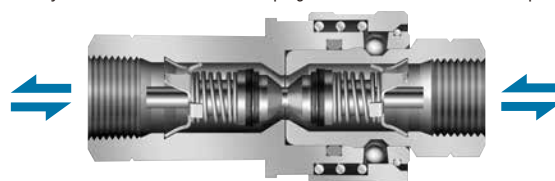

## Interchangeability (See page 8 for details.)

Different sizes are not interchangeable each other. Cannot be connected with the SP-V Cupla.

## Flow Rate – Pressure Loss Characteristics

[Test conditions] • Fluid : Water • Temperature : 24°C ± 6°C

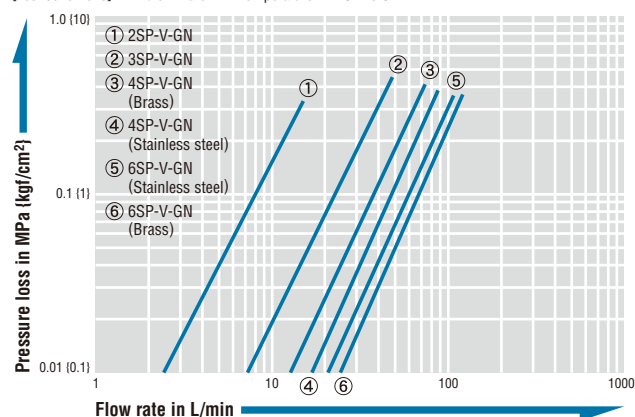



**Models and Dimensions (WAF : WAF stands for width across flats.)**

Socket					
Model	Application	Dimensions (mm)			
		L	øD	H (WAF)	T
2S-V-GN	R 1/4	58	28	19	Rc 1/4
3S-V-GN	R 3/8	65	35	21	Rc 3/8
4S-V-GN	R 1/2	72	45	29	Rc 1/2
6S-V-GN	R 3/4	88	55	35	Rc 3/4

Plug					
Model	Application	Dimensions (mm)			
		L	H (WAF)	C	T
2P-V-GN	R 1/4	36	Hex. 17	22	Rc 1/4
3P-V-GN	R 3/8	40	Hex. 21	25	Rc 3/8
4P-V-GN	R 1/2	44	Hex. 29	28	Rc 1/2
6P-V-GN	R 3/4	52	Hex. 35	36	Rc 3/4

**Detailed Comparison of the SP-V and SP-V-GN Plugs**

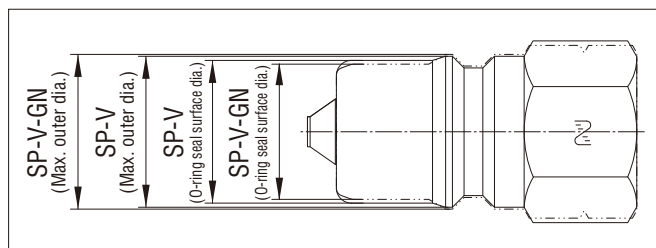

**Interchangeability**

**When a plug of SP-V type is inserted into a socket of SP-V-GN type**

A plug of SP-V type cannot be inserted any further into a socket of SP-V-GN type as shown in the figure to the left due to the outer diameter of the plug, where the surface is sealed by O-ring, being larger than the inner diameter of the socket. Therefore, the plug and socket cannot be connected and the shut-off valves in both Cuplas do not open.

**When a plug of SP-V-GN type is inserted into a socket of SP-V type**

A plug of SP-V-GN type cannot be inserted any further into a socket of SP-V type as shown in the figure to the left due to the outer diameter of the plug being larger than the inner diameter of the socket. Therefore, the plug and socket cannot be connected and the shut-off valves in both Cuplas do not open.

**SP-V-GNN Cupla**

We also manufacture the SP-V-GNN type which has no interchangeability (non-interchangeable type) with the SP-V and SP-V-GN types.

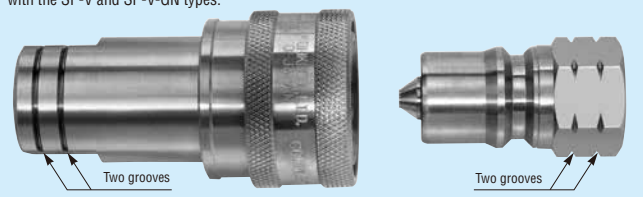

**Double O-ring Version of SP-V-GN Cupla**

**SP-V-GN Cupla S-V-GN-W Type**

Employs a double O-ring sealing structure in the socket of SP-V-GN Cupla to achieve high airtightness. Highly effective in airtightness and vacuum resistance when connected!

**Specifications**

The same specifications as the SP-V-GN Cupla. Please refer to the specifications of SP-V-GN Cupla (Page 7).

**Dimensions**

The same dimensions as the SP-V-GN Cupla. Please refer to the dimensions of SP-V-GN Cupla (Page 8).

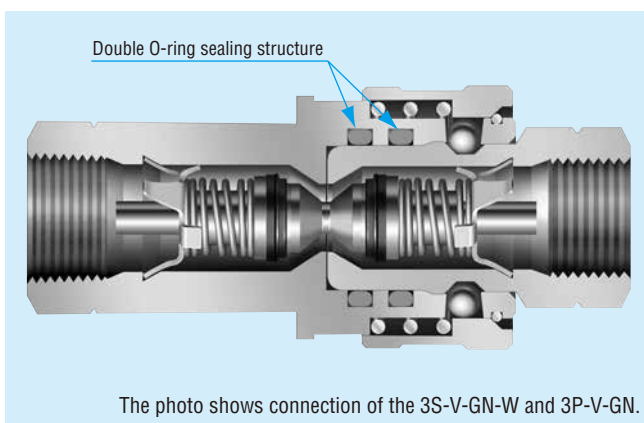

Model	Application
2S-V-GN-W	R 1/4
3S-V-GN-W	R 3/8
4S-V-GN-W	R 1/2
6S-V-GN-W	R 3/4

Note: No lubricant is applied to HNBR O-ring in the socket. Please apply refrigerant oil to O-ring before use.

For Connection to Copper Pipes

# PCV Pipe Cupla

Clamps directly on a straight copper pipe eliminating unnecessary welding or flaring. Double seal construction withstands a vacuum of up to  $1.3 \times 10^{-1}$  Pa. Suits for refrigerants that require high pressure.

- Withstands a vacuum of up to  $1.3 \times 10^{-1}$  Pa ( $1 \times 10^{-3}$  mmHg) (when connected) making it possible to be used in leak test, vacuum suction and refrigerant charge.
- Select from three standard types of seal materials to be used with fluids for air conditioner and refrigerator production lines. Many models to suit various pipe sizes.
- One lever operation simultaneously clamps and seals pipe. Double seal construction for tight fit on end and outside surface of pipe ensures excellent sealing and vacuum resistance.

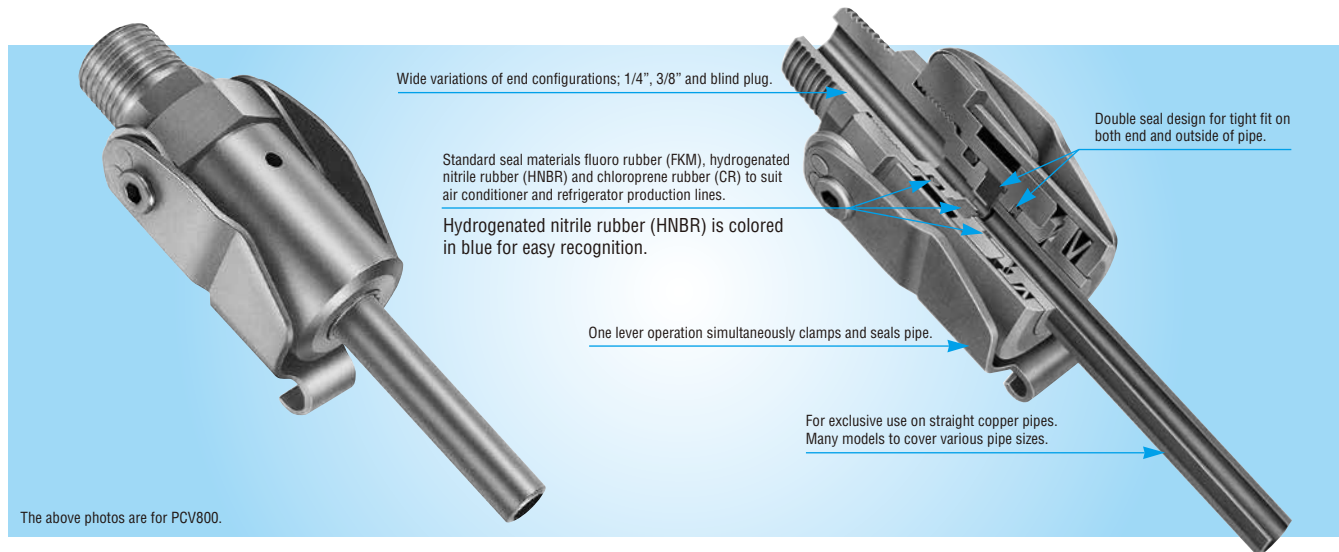

## Specifications

Model	PCV400	PCV470	PCV500	PCV600	PCV630	PCV800	PCV950	PCV1000	PCV1270	PCV1590
Copper pipe OD	ø4.0	ø4.76 (3/16")	ø5.0	ø6.0	ø6.35 (1/4")	ø8.0 (5/16")	ø9.52 (3/8")	ø10.0	ø12.7 (1/2")	ø15.88 (5/8")
Body material	Brass									
Working pressure	4.5 MPa, 46 kgf/cm <sup>2</sup> , 45 bar, 653 PSI									
Seal material	Seal material	Mark	Working temperature range	Remarks						
	Chloroprene rubber	CR (C308)	-20°C to +80°C	Standard material						
	Fluoro rubber	FKM (X-100)	-20°C to +180°C							
Hydrogenated nitrile rubber	HNBR (H708)	-20°C to +120°C								

## Clamping Mechanism

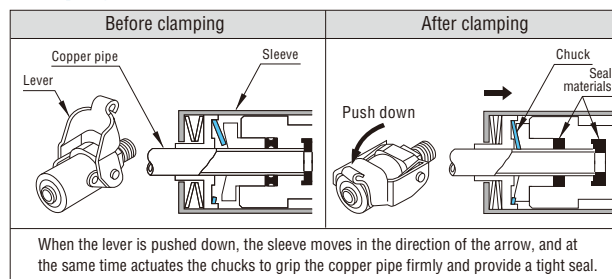

## Max. Tightening Torque (Nm (kgf·cm))

Size (Thread)	1/4"	3/8"
Torque	9 (92)	12 (122)

## Min. Cross-Sectional Area (mm<sup>2</sup>)

Model	PCV400	PCV470	PCV500	PCV600	PCV630	PCV800
Min. cross-sectional area	3.8	3.8	3.8	9.1	9.1	16.6
Model	PCV950	PCV1000	PCV1270-2	PCV1270-3	PCV1590-2	PCV1590-3
Min. cross-sectional area	16.6	16.6	50.3	73.9	50.3	78.5

## Suitability for Vacuum ( $1.3 \times 10^{-1}$ Pa { $1 \times 10^{-3}$ mmHg})

Cupla only	When connected to a pipe
—	Operational

## Interchangeability

A pipe can be connected to any model within the product group as shown in Page 10 regardless of the size (T) for mounting. A Cupla can be connected to any pipe with an odd shape provided that a pipe has appropriate outside diameter and enough insertion length.

## Pipe Outside Diameter, Insert Length of Pipe into Cupla, and Minimum Thickness of Pipe Wall (mm)

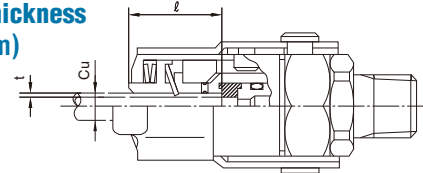

Items with asterisk (\*) are made-to-order products.

Product Group	Pipe OD (Cu)	Insert Length of Pipe into Cupla (l)	Minimum Thickness of Pipe Wall (t)
PCV400*	ø4.0	19	0.8 or more
PCV470	ø4.76 (3/16")		
PCV500*	ø5.0		
PCV600	ø6.0		
PCV630	ø6.35 (1/4")	20.5	0.8 or more
PCV800	ø8.0 (5/16")		
PCV950	ø9.52 (3/8")		
PCV1000*	ø10.0	30	1.0 or more
PCV1270	ø12.7 (1/2")		
PCV1590	ø15.88 (5/8")		

Please contact us for a pipe that has short insertion length or thin wall.

**Models and Dimensions (WAF : WAF stands for width across flats.)**

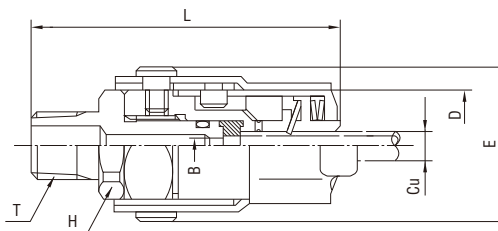
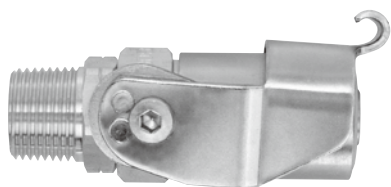

The above photo is for PCV800.

Product Group	Pipe OD (Cu)	Model	Application	Mass (g)	Dimensions (mm)					
					L	øD	H (WAF)	øB	E	T
PCV400*	ø4.0	PCV400-2	Rc 1/4	155	(59)	22.2	Hex. 17	2.2	(32.5)	R 1/4
		PCV400-3	Rc 3/8	155	(60)		Hex. 19			R 3/8
PCV470	ø4.76 (3/16")	PCV470-2	Rc 1/4	155	(60)	22.2	Hex. 17	2.2	(32.5)	R 1/4
		PCV470-3	Rc 3/8	160	(61)		Hex. 19			R 3/8
		PCV470-0	Blind plug	160	(47)		-			-
PCV500*	ø5.0	PCV500-2	Rc 1/4	155	(59)	22.2	Hex. 17	2.2	(32.5)	R 1/4
		PCV500-3	Rc 3/8	155	(60)		Hex. 19			R 3/8
PCV600	ø6.0	PCV600-2	Rc 1/4	150	(60)	22.2	Hex. 17	3.4	(32.5)	R 1/4
		PCV600-3	Rc 3/8	155	(61)		Hex. 19			R 3/8
		PCV600-0	Blind plug	155	(47)		-			-
PCV630	ø6.35 (1/4")	PCV630-2	Rc 1/4	145	(60)	22.2	Hex. 17	3.4	(32.5)	R 1/4
		PCV630-3	Rc 3/8	150	(61)		Hex. 19			R 3/8
		PCV630-0	Blind plug	150	(47)		-			-
PCV800	ø8.0 (5/16")	PCV800-2	Rc 1/4	175	(62)	24.8	Hex. 17	4.6	(35.5)	R 1/4
		PCV800-3	Rc 3/8	180	(63)		Hex. 19			R 3/8
		PCV800-0	Blind plug	185	(50)		-			-
PCV950	ø9.52 (3/8")	PCV950-2	Rc 1/4	175	(62)	24.8	Hex. 17	4.6	(35.5)	R 1/4
		PCV950-3	Rc 3/8	180	(63)		Hex. 19			R 3/8
		PCV950-0	Blind plug	180	(50)		-			-
PCV1000*	ø10.0	PCV1000-2	Rc 1/4	155	(62)	24.8	Hex. 17	4.6	(35.5)	R 1/4
		PCV1000-3	Rc 3/8	155	(63)		Hex. 19			R 3/8
PCV1270	ø12.7 (1/2")	PCV1270-2	Rc 1/4	470	(80)	34.8	Hex. 24	8.0	(45.0)	R 1/4
		PCV1270-3	Rc 3/8	465	(81)		Hex. 24			R 3/8
		PCV1270-0	Blind plug	475	(68)		-			-
PCV1590	ø15.88 (5/8")	PCV1590-2	Rc 1/4	424	(80)	34.8	Hex. 24	8.0	(45.0)	R 1/4
		PCV1590-3	Rc 3/8	435	(81)		Hex. 24			R 3/8
		PCV1590-0	Blind plug	445	(68)		-			-

For mass with a plug, add (brass body) 2P-V: 39 g, 3P-V: 67 g, (stainless body) 2P-V: 34 g, or 3P-V: 59 g \*Items with asterisk (\*) are made-to-order products.

**PCV Pipe Cupla with Plug**

- Specify the plug type (SP-V, SP-V-GN), the body material and seal material when ordering.
- The Loctite (medium strength 242) is used as standard for the plug mounting adhesive. Should you require other adhesive or method such as a thread seal tape, please specify.

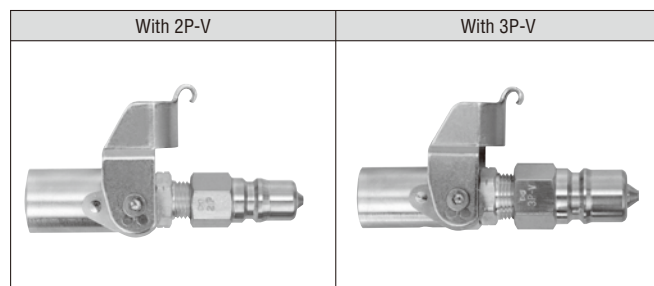

Elbow types are also available.

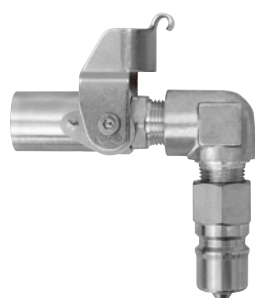

**PCV Pipe Cupla with Plug (With Identification Ring)**

- When several refrigerants are used on the production line simultaneously, PCV Cupla with colored rings are available for visual recognition and to distinguish the seal material used.

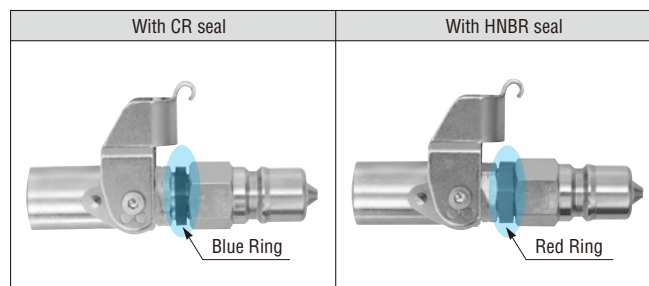

**PCV Pipe Cupla with a Water Drain Hole in the Sleeve**

When a PCV Pipe Cupla is used in a water tank for leak test, a Cupla with a water drain hole in the Sleeve is available as a made-to-order product. Water can be drained from the Cupla easily.

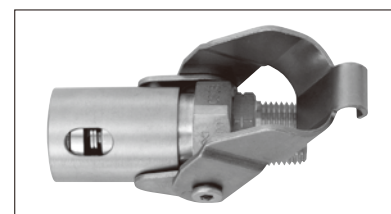

For Connection to Copper Pipes

# Pipe Cupla PCVH Type

Lever shape has been changed for smooth operation. Clamps directly on a straight copper pipe eliminating unnecessary welding or flaring. Double seal construction withstands a vacuum of up to  $1.3 \times 10^{-1}$  Pa.

Lever shape has been changed from curled to straight for smooth operation.

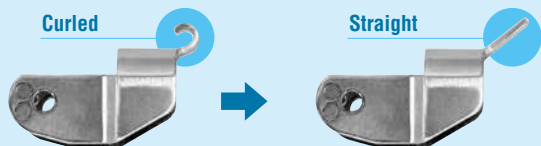

- The same specifications as the PCV Pipe Cupla. Please refer to the specifications of PCV Pipe Cupla (Page 9).
- Withstands a vacuum of up to  $1.3 \times 10^{-1}$  Pa ( $1 \times 10^{-3}$  mmHg) (when connected) making it possible to be used in leak test, vacuum suction and refrigerant charge.
- Select from three standard types of seal materials to be used with fluids for air conditioner and refrigerator production lines. Many models to suit various pipe sizes.
- One lever operation simultaneously clamps and seals pipe. Double seal construction for tight fit on end and outside surface of pipe ensures excellent sealing and vacuum resistance.

### Pipe Cupla PCVH Type with Plug

The PCVH type with plug is available on request as in the case of PCV Pipe Cupla with plug. Please see Page 10.

### Pipe Cupla PCVH Type with Plug (With Identification Ring)

The PCVH Type with identification ring will be handled as in the case of PCV Pipe Cupla with plug when requested. Please see page 10.

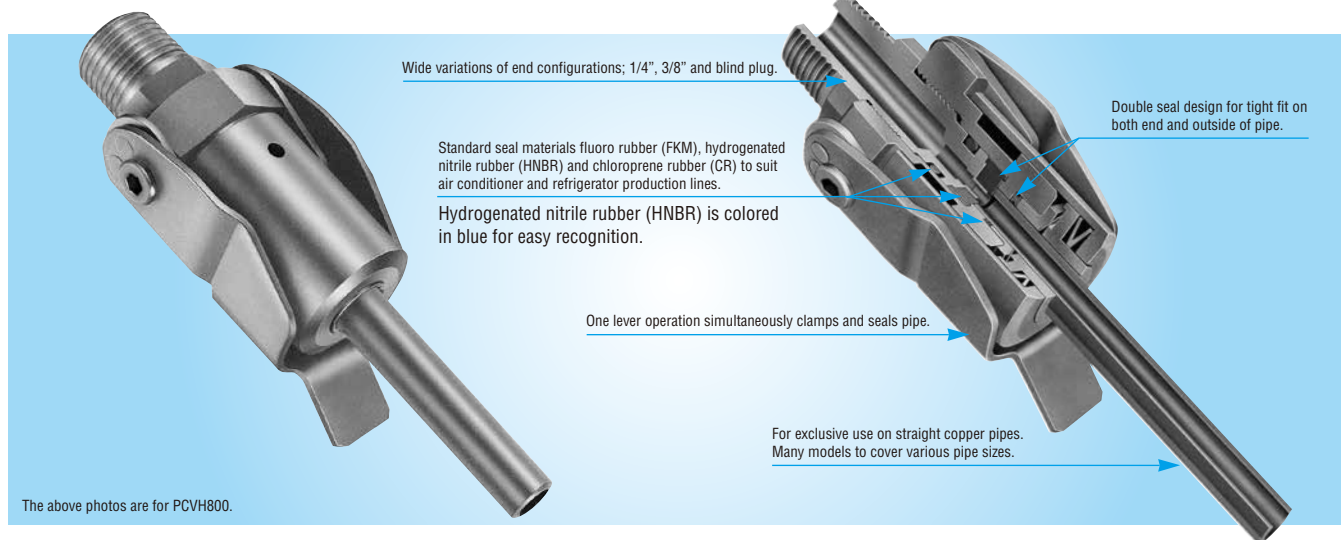

The above photos are for PCVH800.

## Triple Seal Version of PCV Pipe Cupla

# Pipe Cupla PCV-W Type

A triple seal structure is employed, one at the end of pipe and two on the outside of pipe. Highly effective for airtightness and vacuum holding.

### Specifications

The same specifications as the PCV Pipe Cupla. Please refer to the specifications of PCV Pipe Cupla (Page 9).

### Dimensions

The same dimensions as the PCV Pipe Cupla. Please refer to the dimensions of PCV Pipe Cupla (Page 10).

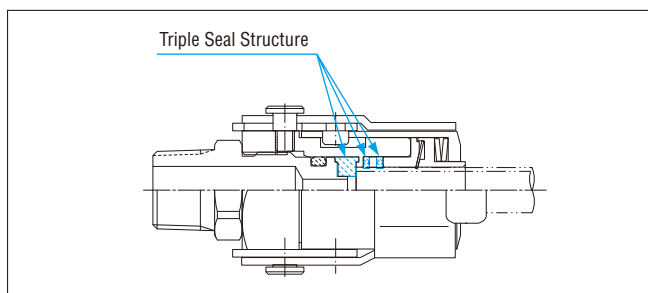
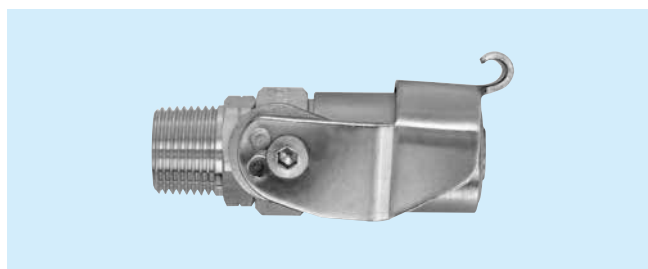

For Connection to Male Thread

# Screw Cupla PCS Type

By pushing the Screw Cupla direct to the male thread for connection improves operating efficiency. Built-in Ball lock sleeve prevents accidental disconnection, ensuring safe operation.

- The models listed below can be connected directly to UNF thread.
- Simply push the Cupla onto the thread. The safety design ensures an instant and secure grip on the thread with the locking claws upon connection.
- Sleeve lock mechanism prevents accidental disconnection.
- Employing a three-terraced-shape lip packing enables more stable seal performance opposed to conventional packing and O-rings.
- Hydrogenated nitrile rubber (HNBR) is colored in blue for easy recognition.
- Time-consuming screw tightening work is eliminated, resulting in reduced connection time.

### Specifications

Body material	Steel (Partly Stainless Steel and Brass)		
Counterpart Size	For 7/16-20UNF, 5/8-18UNF, 3/4-16UNF, 7/8-14UNF, and 1-1/16-14UNS		
Working pressure	3.0 MPa, 31 kgf/cm <sup>2</sup> , 30 bar, 345 PSI		
Seal material Working temperature range	Seal material	Mark	Working temperature range
	Chloroprene rubber	CR (C308)	-20°C to +80°C
	Hydrogenated nitrile rubber	HNBR (H708)	-20°C to +120°C

### Models and Dimensions (WAF : WAF stands for width across flats.)

				Socket				
Product Group	External thread for connection	Model	Application	Dimensions (mm)				
				L	øD	øB	H (WAF)	T
PCS-7U	7/16-20UNF	PCS-7U-2	Rc 1/4	55	28	4	Hex. 19	R 1/4
		PCS-7U-3	Rc 3/8					R 3/8
PCS-10U	5/8-18UNF	PCS-10U-2	Rc 1/4	63	34	7	Hex. 21	R 1/4
		PCS-10U-3	Rc 3/8					R 3/8
PCS-12U	3/4-16UNF	PCS-12U-2	Rc 1/4	71.5	40	7	Hex. 24	R 1/4
		PCS-12U-3	Rc 3/8					10
PCS-14U	7/8-14UNF	PCS-14U-2	Rc 1/4	75.5	43	7	Hex. 27	R 1/4
		PCS-14U-3	Rc 3/8					10
PCS-17U	1 1/16-14UNS	PCS-17U-3	Rc 3/8	75	51	11	Hex. 35	R 3/8



### Screw Cupla PCS Type with Plug

The Screw Cupla PCS Type with Plug is available on request as in the case of PCV Pipe Cupla with Plug including identification ring. Please refer to Page 10.



							Application	
							UNF thread: Pursuant to JIS B 8607	
							UNF thread dimensions (mm)	
øE	øF	R	B	C	øA	T2		
5.5	9.2	45° to 46°	3.7	7.6 or more	4.8	7/16-20UNF		
8	13.5	45° to 46°	4.8	9.2 or more	7	5/8-18UNF		
11	16	45° to 46°	5.5	11.3 or more	10	3/4-16UNF		
13.5	19	45° to 46°	6	13.9 or more	12.5	7/8-14UNF		
18	24	45° to 46°	6	17.4 or more	16	1 1/16-14UNS		

### High Pressure Version of Screw Cupla PCS Type

# Screw Cupla PCS-HP Type

Suits for refrigerants that require high pressure. By pushing the Screw Cupla direct to the male thread for connection improves operating efficiency.

- Can be connected directly to UNF thread.

### Specifications

Body material	Steel (Partly Stainless Steel and Brass)		
Counterpart Size	For 7/16-20UNF, 5/8-18UNF, 3/4-16UNF, 7/8-14UNF, and 11/16-14UNS		
Working pressure	4.5 MPa, 46 kgf/cm <sup>2</sup> , 45 bar, 653 PSI		
Seal material Working temperature range	Seal material	Mark	Working temperature range
	Chloroprene rubber	CR (C308)	-20°C to +80°C
	Hydrogenated nitrile rubber	HNBR (H708)	-20°C to +120°C

### Dimensions

The same dimensions as the Screw Cupla PCS type. Please refer to the dimensions of the Screw Cupla PCS type.

For Charging Industrial Gases and Refrigerants

# Charge Cupla CS Type

Frequent connection and disconnection under pressure can be easily made with the unique lever operation. Perfect for charging refrigerant, vacuum suction, and discharging residual pressure.

- Equipped with an automatic shut-off valve. Fluid in the passage is prevented from flowing out when disconnected.
- The Charge Cupla and Plug can be connected or disconnected even when the residual pressure remains. The shut-off valve can be opened or closed with the lever on the back end.
- The safety design prevents the valve from opening even if the lever is operated without connecting to the plug.
- The lever can be set to any position within the 360 degrees.
- The CS type can be connected to the standard 2P-V and 3P-V Plugs.
- The CS-GN type is also available for the 2P-V-GN and 3P-V-GN Plugs on request.
- Hydrogenated nitrile rubber (HNBR) is colored in blue for easy recognition.
- The Charge Cupla that employs a double O-Ring seal structure for high airtightness is also available on request.



**A general rule for identification**

- A Charge Cupla with CR seal : The body and grip are coated with blue colored anodic oxidized alumina.
- A Charge Cupla with HNBR seal : The body and grip are coated with red colored anodic oxidized alumina.
- Please contact us should you require any other color.

**Specifications**

Body material	Stainless Steel (Partly Aluminum and Brass)		
Size (Thread)	1/4"		
Working pressure	3.0 MPa, 31 kgf/cm <sup>2</sup> , 30 bar, 435 PSI		
Seal material Working temperature range	Seal material	Mark	Working temperature range
	Chloroprene rubber	CR (C308)	-20°C to +80°C
	Hydrogenated nitrile rubber	HNBR (H708)	-20°C to +120°C

**Min. Cross-Sectional Area (mm<sup>2</sup>)**

Model	CS-2S-V × 2P-V	CS-3S-V × 3P-V
Min. cross-sectional area	17	44

**Combined Overall Length (mm)**

Model	CS-2S-V × 2P-V	CS-3S-V × 3P-V
Combined Overall Length	245.5	250.5

**How to Use**

**Connection to Plug**

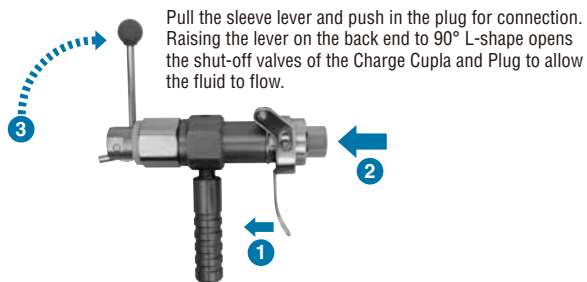

**Disconnection of Plug**

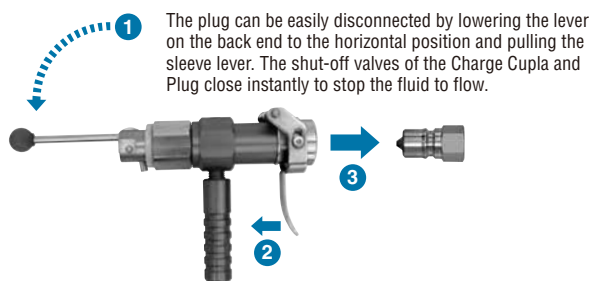

**Models and Dimensions**

**Socket**

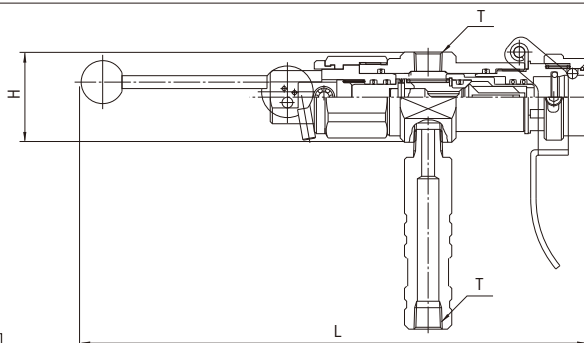

Model	Connecting Plug	Dimensions (mm)		
		L	øH	T
CS-2S-V	2P-V	232.5	42	Rc 1/4
CS-3S-V	3P-V	235.5	42	Rc 1/4

Suits for Refrigerants That Require High Pressure

# Charge Cupla CS-HP Type

Suits for refrigerants that require high pressure. High pressure version of the CS type. Frequent connection and disconnection under pressure can be easily made with the unique lever operation.

- Equipped with an automatic shut-off valve. Fluid in the passage is prevented from flowing out when disconnected.
- The Charge Cupla and Plug can be connected or disconnected even when the residual pressure remains. The shut-off valve can be opened or closed with the lever on the back end.
- The safety design prevents the valve from opening even if the lever is operated without connecting to the plug.
- The lever can be set to any position within the 360 degrees.
- The CS-HP type can be connected to the standard 2P-V, 3P-V, and 4P-V Plugs. The CS-HP-GN type is also available for the 2P-V-GN, 3P-V-GN, and 4P-V-GN Plugs on request.
- The Charge Cupla that employs a double O-Ring seal structure for high airtightness is also available on request.



**A general rule for identification**

- A Charge Cupla with CR seal : The body and grip are coated with blue colored anodic oxidized alumina.
- A Charge Cupla with HNBR seal : The body and grip are coated with red colored anodic oxidized alumina.
- Please contact us should you require any other color.

### Specifications

Body material	Stainless Steel (Partly Aluminum and Brass)		
Size (Thread)	1/4", 1/2"		
Working pressure	4.5 MPa, 46 kgf/cm <sup>2</sup> , 45 bar, 653 PSI		
Seal material Working temperature range	Seal material	Mark	Working temperature range
	Chloroprene rubber	CR (C308)	-20°C to +80°C
	Hydrogenated nitrile rubber	HNBR (H708)	-20°C to +120°C

### Min. Cross-Sectional Area (mm<sup>2</sup>)

Model	CS-2S-V-HP × 2P-V	CS-3S-V-HP × 3P-V	CS-4S-V-HP × 4P-V
Min. cross-sectional area	17	44	71

### Combined Overall Length (mm)

Model	CS-2S-V-HP × 2P-V	CS-3S-V-HP × 3P-V	CS-4S-V-HP × 4P-V
Combined Overall Length	263	267	297

### Models and Dimensions

#### Socket

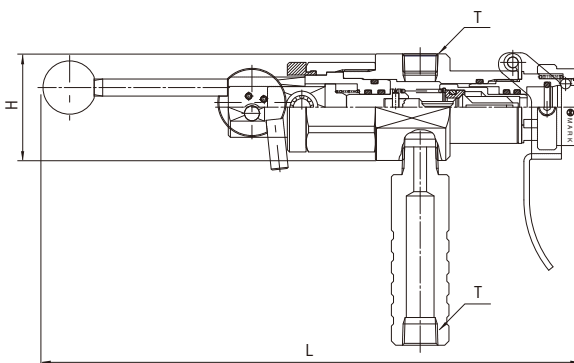

Model	Connecting Plug	Dimensions (mm)		
		L	øH	T
CS-2S-V-HP	2P-V	250	43	Rc 1/4
CS-3S-V-HP	3P-V	252	43	Rc 1/4
CS-4S-V-HP	4P-V	273	50	Rc 1/2

### How to Use

#### Connection to Plug

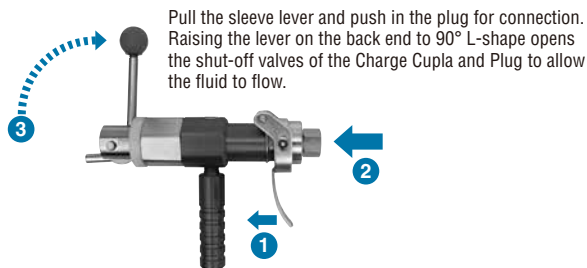

#### Disconnection of Plug

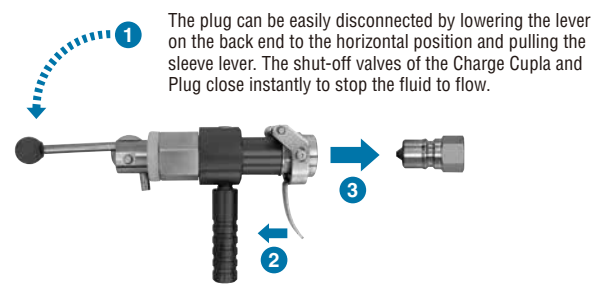

Note: No lubricant is applied to HNBR O-ring in the socket. Please apply refrigerant oil to O-ring before use.

For charging Industrial Gases and Refrigerants

# Charge Cupla CNR Type/LRP Type

Easy disconnection from the plug by lifting the lever to discharge the residual pressure. Perfect for charging refrigerant, vacuum suction, and connection/disconnection under residual pressure.

- Equipped with an automatic shut-off valve. Fluid in the passage is prevented from flowing out when disconnected.
- The Charge Cupla and Plug can be connected or disconnected even when the residual pressure remains. The shut-off valve can be opened or closed with the lever on the back.
- Employs a double O-ring sealing structure for high air-tightness upon connection.
- The safety design prevents the valve from opening even if the lever is operated without connecting to the plug.
- Easy disconnection from the plug by lifting the lever to discharge the residual pressure after charging is complete.
- The CNR type can be connected to the standard 3P-V and 4-PV Plugs, and the LRP type to the standard 2P-V Plug. The CNR-GN type is also available for the 3P-V-GN and 4P-V-GN Plugs, and LRP-GN type for the 2P-V-GN Plug on request.
- Hydrogenated nitrile rubber (HNBR) is colored in blue for easy recognition.

## Specifications

Body material	Stainless Steel (Partly Aluminum and Brass)		
Size (Thread)	1/4", 3/8", 1/2"		
Working pressure	4.5 MPa, 46 kgf/cm <sup>2</sup> , 45 bar, 653 PSI		
Seal material Working temperature range	Seal material	Mark	Working temperature range
	Chloroprene rubber	CR (C308)	-20°C to +80°C
	Hydrogenated nitrile rubber	HNBR (H708)	-20°C to +120°C

## Min. Cross-Sectional Area (mm<sup>2</sup>)

Model	CNR-3S × 3P-V	CNR-4S × 4P-V	LRP-2S × 2P-V
Min. cross-sectional area	44	62	17

## Combined Overall Length (mm)

Model	CNR-3S × 3P-V	CNR-4S × 4P-V	LRP-2S × 2P-V
Combined Overall Length	136	161	110

## Models and Dimensions (WAF : WAF stands for width across flats.)

### Socket

#### CNR Type

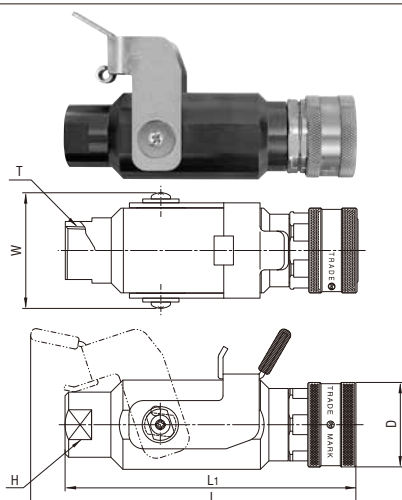

Model	Connecting Plug	Dimensions (mm)					
		L	L <sub>1</sub>	øD	W	H (WAF)	T
CNR-3S	3P-V	135	121	35	(48)	24	Rc 3/8
CNR-4S	4P-V	161	145	45	(54)	32	Rc 1/2

#### LRP Type

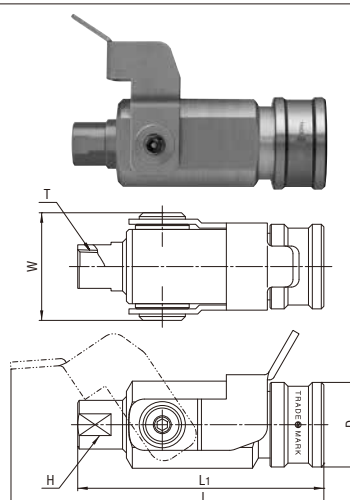

Model	Connecting Plug	Dimensions (mm)					
		L	L <sub>1</sub>	øD	W	H (WAF)	T
LRP-2S-V	2P-V	123	96	33	(42)	17	Rc 1/4



## How to Use

### Connection to Plug

Pull the sleeve on the Charge Cupla and insert the plug into the Charge Cupla for easy connection.

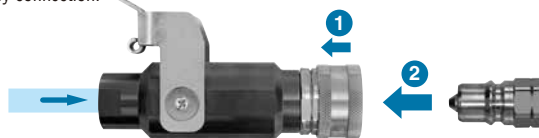

Lowering the lever opens the valve to allow fluid flow.



### Disconnection of Plug

Lifting the lever discharges the remaining pressure between the valves in the Charge Cupla and plug. The plug can then be easily disconnected by pulling the sleeve on the Charge Cupla. Upon disconnection the valves in both sides close the flow passage instantly to prevent fluid from flowing out.



Prior to connecting/disconnecting the plug, reduce the fluid pressure below 1.0 MPa. The lever will spring back when pulled back with pressure remaining inside. Be careful not to get your fingers caught in the Cupla.



For Charging Industrial Gases and Refrigerants

# Airless Charge Cupla CNA Type

The Airless valve structure minimizes air ingress on connection and fluid spillage on disconnection. Perfect for charging refrigerant, vacuum suction, and connection/disconnection under residual pressure.

- A special airless valve structure is employed in both socket and plug. This minimizes air ingress on connection and fluid spillage on disconnection. (CNA-GN Type is also available on request.)
- The Airless Charge Cupla and Plug can be connected or disconnected even when the residual pressure remains. The airless shut-off valve can be opened or closed with the lever on the back.
- The safety design prevents the valve from opening even if the lever is operated without connecting to the plug.



## Specifications

Body material	Stainless Steel (Partly Aluminum and Brass)		
Size (Thread)	3/8"		
Working pressure	3.0 MPa, 31 kgf/cm <sup>2</sup> , 30 bar, 435 PSI		
Seal material	Hydrogenated nitrile rubber	Mark	HNBR (H708)
Working temperature range	-20°C to +120°C		

## Min. Cross-Sectional Area (mm<sup>2</sup>)

Model	CNA-3S-V × CNA-3P-V
Min. cross-sectional area	31.5

## Combined Overall Length (mm)

Model	CNA-3S-V × CNA-3P-V
Combined Overall Length	111

## How to Use

### Connection to Plug

Pull the sleeve on the Charge Cupla and insert the plug for easy connection. Lowering the lever opens the valve to allow fluid flow.

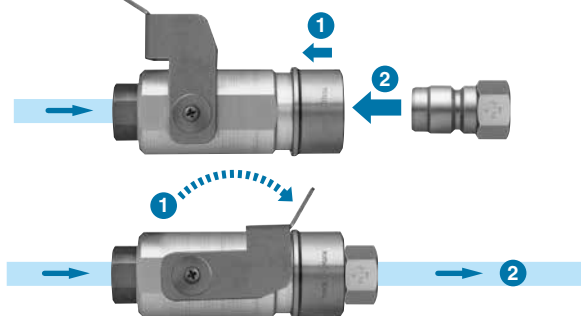

### Disconnection of Plug

The plug can be easily disconnected by lifting the lever and pulling the sleeve on the Charge Cupla. Upon disconnection the valves in both sides close the flow passage instantly to prevent fluid from flowing out.

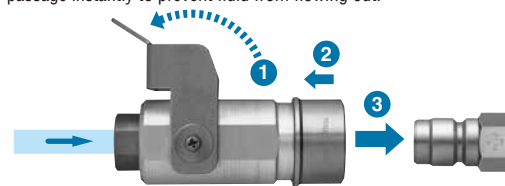

## Models and Dimensions (WAF : WAF stands for width across flats.)

### Socket

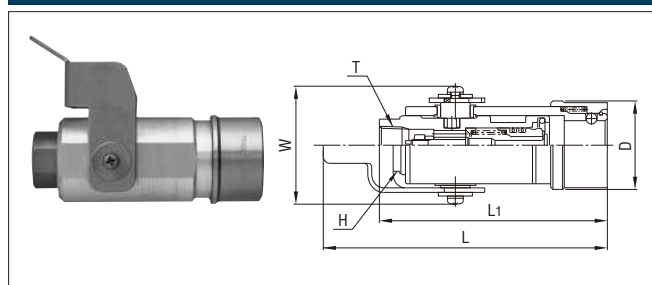

Model	Application	Dimensions (mm)					
		L	L <sub>1</sub>	øD	W	H (WAF)	T
CNA-3S-V	R 3/8	114	103	38	(48)	23	Rc 3/8

### Plug

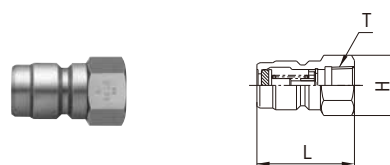

Model	Application	Dimensions (mm)		
		L	H (WAF)	T
CNA-3P-V	R 3/8	43	Hex. 23	Rc 3/8

**Air-driven Mechanism for Plug Disconnection**

# Auto Cupla ACV Type

**Automatic Plug Disconnection Type.**  
**Contributes to energy and labor saving on the production line.**  
**Simply push the Plug into the Auto Cupla for connection.**

- Air-driven mechanism is employed in the Auto Cupla to disconnect the plug. For an emergency, manual disconnection is possible. An automatic shut-off valve in the Auto Cupla prevents fluid from spilling on disconnection.
- The ACV type can be connected to the standard 2P-V and 3P-V Plugs. The ACV-GN type is also available for the 2P-V-GN and 3P-V-GN Plugs on request.
- Hydrogenated nitrile rubber (HNBR) is colored in blue for easy recognition.



**Specifications**

Body material	Stainless Steel (Partly Aluminum and Brass)		
Size (Thread)	1/4", 3/8"		
Working pressure	3.0 MPa, 31 kgf/cm <sup>2</sup> , 30 bar, 435 PSI		
Seal material Working temperature range	Seal material	Mark	Working temperature range
	Chloroprene rubber	CR (C308)	-20°C to +80°C
	Hydrogenated nitrile rubber	HNBR (H708)	-20°C to +120°C
	Nitrile rubber	NBR (SG)	-20°C to +80°C
Maximum Cupla Inner Pressure for Air Operation	When Disconnecting Plug	1.0 MPa, 10 kgf/cm <sup>2</sup> , 10 bar, 142 PSI	

**Auto Cupla is connected to Plug**

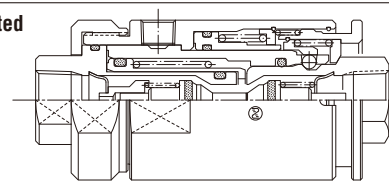

**How to Use**

**Connection to Plug**

Simply push the plug into the Auto Cupla for connection.



Upon connection, the valves in the Auto Cupla and plug open instantly to allow the fluid flow.



**Disconnection of Plug**

Prior to disconnecting the plug, reduce the fluid pressure below 1.0 MPa (10 kgf/cm<sup>2</sup>). The plug can be automatically disconnected by applying air pressure of 0.5 to 0.6 MPa (5 to 6 kgf/cm<sup>2</sup>) to section A.



**Disconnection of Plug for an emergency**

The plug can be easily disconnected by pulling the front side sleeve in the direction of the arrow.

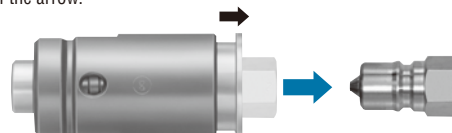

**Models and Dimensions (WAF : WAF stands for width across flats.)**

**Socket**

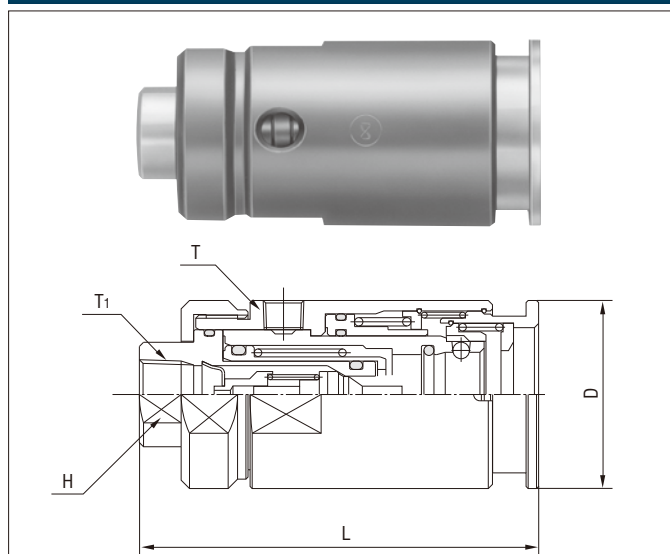

Model	Connecting Plug	Dimensions (mm)				
		L	øD	H (WAF)	T	T1
ACV-2S	2P-V	100	42	19	Rc 1/8	Rc 1/4
ACV-3S	3P-V	96	45	21	Rc 1/8	Rc 3/8

Note: No lubricant is applied to HNBR O-ring in the socket. Please apply refrigerant oil to O-ring before use.

Air-driven Mechanism for Plug Disconnection (High Pressure Version)

# Auto Cupla ACV-HP Type

Suits for refrigerants that require high pressure.  
 High pressure version of the ACV type.  
 Automatic Plug Disconnection Type.  
 Contributes to energy and labor saving on the production line.

- Simply push the plug into the Auto Cupla for connection.
- Air-driven mechanism is employed in the Auto Cupla to disconnect the plug. For an emergency, manual disconnection is possible.
- An automatic shut-off valve in the Auto Cupla prevents fluid from spilling on disconnection.
- The ACV-HP type can be connected to the standard 2P-V and 3P-V Plugs. The ACV-HP-GN type is also available for the 2P-V-GN and 3P-V-GN Plugs on request.



**A general rule for identification**

- An Auto Cupla with CR seal: The body is coated with blue colored anodic oxidized alumina.
- An Auto Cupla with HNBR seal: The body is coated with red colored anodic oxidized alumina.
- Please contact us should you require any other color.

**Specifications**

Body material	Stainless Steel (Partly Aluminum and Brass)		
Size (Thread)	1/4", 3/8"		
Working pressure	4.5 MPa, 46 kgf/cm <sup>2</sup> , 45 bar, 653 PSI		
Seal material Working temperature range	Seal material	Mark	Working temperature range
	Chloroprene rubber	CR (C308)	-20°C to +80°C
	Hydrogenated nitrile rubber	HNBR (H708)	-20°C to +120°C
Maximum Cupla Inner Pressure for Air Operation	When Disconnecting Plug	1.0 MPa, 10 kgf/cm <sup>2</sup> , 10 bar, 142 PSI	

**Models and Dimensions (WAF : WAF stands for width across flats.)**

**Socket**

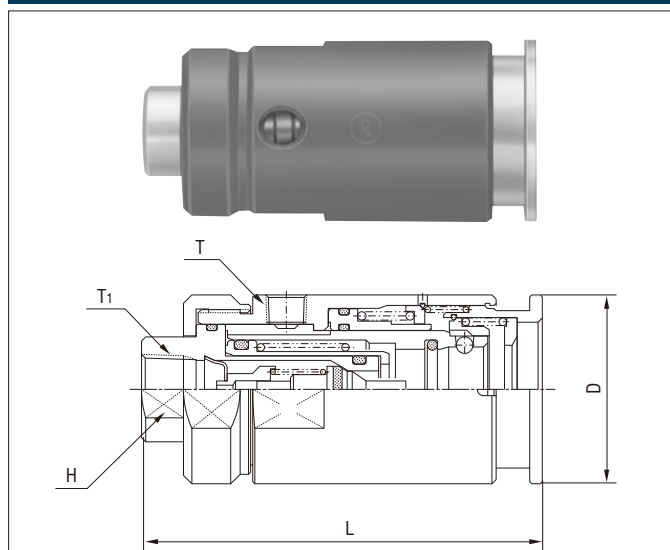

Model	Connecting Plug	Dimensions (mm)				
		L	øD	H (WAF)	T	T1
ACV-2S-HP	2P-V	100	42	19	Rc 1/8	Rc 1/4
ACV-3S-HP	3P-V	96	45	21	Rc 1/8	Rc 3/8

**Auto Cupla is connected to Plug**

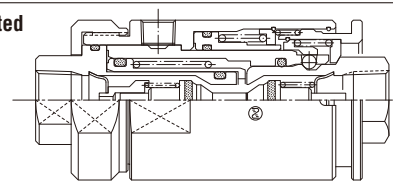

**How to Use**

**Connection to Plug**

Simply push the plug into the Auto Cupla for connection.



Upon connection, the valve in the Auto Cupla and plug open instantly to allow the fluid flow.

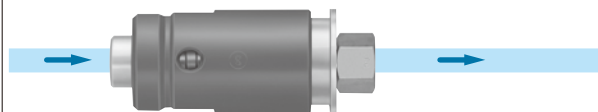

**Disconnection of Plug**

Prior to disconnecting the plug, reduce the fluid pressure below 1.0 MPa (10 kgf/cm<sup>2</sup>). The plug can be automatically disconnected by applying air pressure of 0.5 to 0.6 MPa (5 to 6 kgf/cm<sup>2</sup>) to section A.

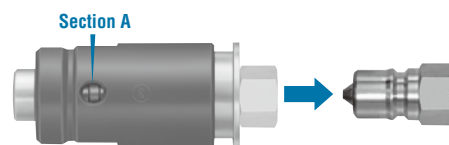

**Disconnection of Plug for an emergency**

The plug can be easily disconnected by pulling the front side sleeve in the direction of the arrow.

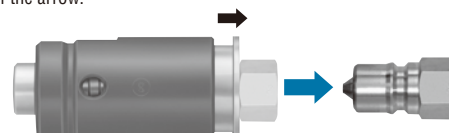

Note: No lubricant is applied to HNBR O-ring in the socket. Please apply refrigerant oil to O-ring before use.

# Auto Cupla AC Type

**Auto Cupla automatically opens and closes the valve, and disconnects the plug. Contributes to energy and labor saving on the production line.**

- Air-driven mechanism is employed in the Auto Cupla to connect and disconnect the plug and to open and close the valve.
- An automatic shut-off valve in the Auto Cupla prevents fluid from spilling on disconnection.
- The unique air-driven mechanism reduces the load when the plug is connected to the Auto Cupla.
- The Auto Cupla and Plug can be connected or disconnected even when the residual pressure remains.
- The safety design prevents the valve from opening even if the valve is operated to open with air-driven mechanism without connecting to the plug.
- The AC type can be connected to the standard 2P-V and 3P-V Plugs. The AC-GN type is also available for the 2P-V-GN and 3P-V-GN Plugs on request.
- Hydrogenated nitrile rubber (HNBR) is colored in blue for easy recognition.

## Specifications

Body material	Stainless Steel (Partly Aluminum and Brass)		
Size (Thread)	1/4", 3/8"		
Working pressure	3.0 MPa, 31 kgf/cm <sup>2</sup> , 30 bar, 435 PSI		
Seal material Working temperature range	Seal material	Mark	Working temperature range
	Chloroprene rubber	CR (C308)	-20°C to +80°C
	Hydrogenated nitrile rubber	HNBR (H708)	-20°C to +120°C
	Nitrile rubber	NBR (SG)	-20°C to +80°C
Maximum Cupla Inner Pressure for Air Operation	When opening and closing the valve	1.0 MPa, 10 kgf/cm <sup>2</sup> , 10 bar, 145 PSI	
	When disconnecting the plug	1.0 MPa, 10 kgf/cm <sup>2</sup> , 10 bar, 145 PSI	

## Models and Dimensions (WAF : WAF stands for width across flats.)

### Socket

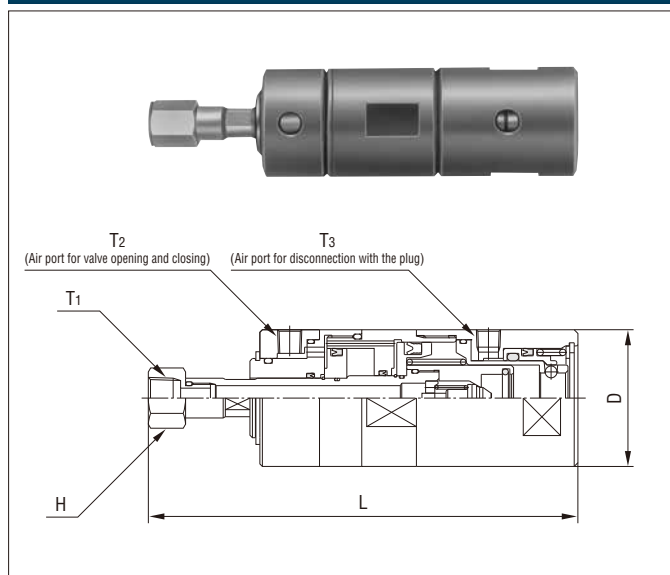

Model	Connecting Plug	Dimensions (mm)					
		L	øD	H (WAF)	T1	T2	T3
AC-2S	2P-V	155	44	Hex. 17	Rc 1/4	Rc 1/8	Rc 1/8
AC-3S	3P-V	173	55	Hex. 21	Rc 3/8	Rc 1/8	Rc 1/8



### Auto Cupla is connected to Plug

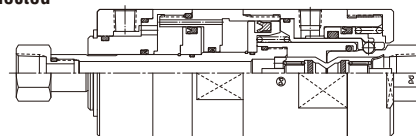

## How to Use

### Connection to Plug

The balls in the Auto Cupla become loose by applying air pressure of 0.5 to 0.6 MPa (5 to 6 kgf/cm<sup>2</sup>) to section A. The plug can then be easily inserted. Completely inserting the plug into the Auto Cupla and reducing the pressure on section A to 0 MPa will lock the Auto Cupla and plug and complete the connection. (\* The valve is not open in this state.)

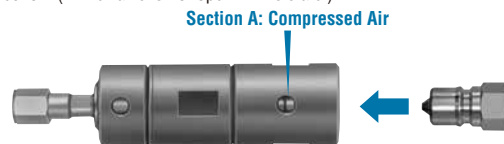

### Opening and Closing the Valve

Prior to operating the valve, reduce the fluid pressure below 1.0 MPa (10 kgf/cm<sup>2</sup>). The valves in the Auto Cupla and plug open by applying air pressure of 0.5 to 0.6 MPa (5 to 6 kgf/cm<sup>2</sup>) to section B. By reducing the air pressure on section B to 0 MPa, the valves in the Auto Cupla and plug close thereby stopping the fluid flow.

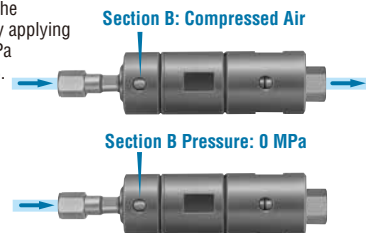

### Disconnection of Plug

Prior to disconnecting the plug, reduce the fluid pressure below 1.0 MPa (10 kgf/cm<sup>2</sup>). The plug can be disconnected by applying air pressure of 0.5 to 0.6 MPa (5 to 6 kgf/cm<sup>2</sup>) to section A after reducing the air pressure on section B to 0 MPa.

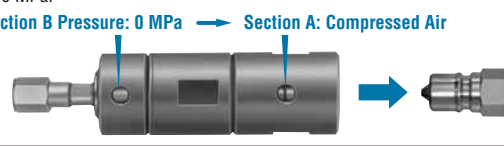

### Auto Cupla ACS Type

The ACS type, which can be connected to the plug by simply pushing the plug into the Auto Cupla, is also available on request.



**Air-driven Mechanism for Valve Opening / Closing and Plug Disconnection (High Pressure Version)**

# Auto Cupla AC-HP Type

**Suits for refrigerants that require high pressure. High pressure version of the AC type. Auto Cupla automatically opens and closes the valve and disconnects the plug. Contributes to energy and labor saving on the production line.**

- Air-driven mechanism is employed in the Auto Cupla to connect and disconnect the plug and to open and close the valve.
- An automatic shut-off valve in the Auto Cupla prevents fluid from spilling on disconnection.
- The unique air-driven mechanism reduces the load when the plug is connected to the Auto Cupla.
- The Auto Cupla and Plug can be connected or disconnected even when the residual pressure remains.
- The safety design prevents the valve from opening even if the valve is operated to open with air-driven mechanism without connecting to the plug.
- The AC-HP type can be connected to the standard 3P-V Plug. The AC-HP-GN type is also available for the 3P-V-GN Plug on request.



## Specifications

Body material	Stainless Steel (Partly Aluminum and Brass)		
Size (Thread)	3/8"		
Working pressure	4.5 MPa, 46 kgf/cm <sup>2</sup> , 45 bar, 653 PSI		
Seal material	Seal material	Mark	Working temperature range
Working temperature range	Hydrogenated nitrile rubber	HNBR (H708)	-20°C to +120°C
Maximum Cupla Inner Pressure for Air Operation	When opening and closing the valve	1.0 MPa, 10 kgf/cm <sup>2</sup> , 10 bar, 145 PSI	
	When disconnecting the plug	1.0 MPa, 10 kgf/cm <sup>2</sup> , 10 bar, 145 PSI	

## Models and Dimensions (WAF : WAF stands for width across flats.)

### Socket

Model	Connecting Plug	Dimensions (mm)					
		L	øD	H (WAF)	T1	T2	T3
AC-3S-HP	3P-V	176	65	Hex. 21	Rc 3/8	Rc 1/8	Rc 1/8

**Auto Cupla is connected to Plug**

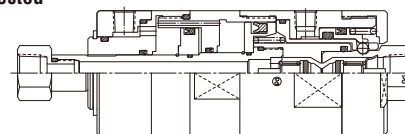

## How to Use

### Connection to Plug

The balls in the Auto Cupla become loose by applying air pressure of 0.5 to 0.6 MPa (5 to 6 kgf/cm<sup>2</sup>) to section A. The plug can then be easily inserted. Completely inserting the plug into the Auto Cupla and reducing the pressure on section A to 0 MPa will lock the Auto Cupla and plug and complete the connection. (\* The valve is not open in this state.)

**Section A: Compressed Air**



### Opening and Closing the Valve

Prior to operating the valve, reduce the fluid pressure below 1.0 MPa (10 kgf/cm<sup>2</sup>). The valves in the Auto Cupla and plug open by applying air pressure of 0.5 to 0.6 MPa (5 to 6 kgf/cm<sup>2</sup>) to section B. By reducing the air pressure on section B to 0 MPa, the valves in the Auto Cupla and plug close thereby stopping the fluid flow.

**Section B: Compressed Air**



**Section B Pressure: 0 MPa**

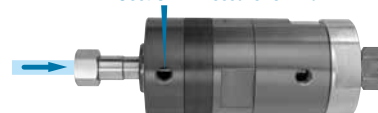

### Disconnection of Plug

Prior to disconnecting the plug, reduce the fluid pressure below 1.0 MPa (10 kgf/cm<sup>2</sup>). The plug can be disconnected by applying air pressure of 0.5 to 0.6 MPa (5 to 6 kgf/cm<sup>2</sup>) to section A after reducing the air pressure on section B to 0 MPa.

**Section B Pressure: 0 MPa → Section A: Compressed Air**

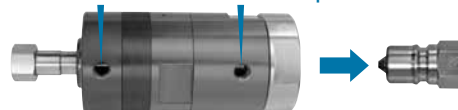

Note: No lubricant is applied to HNBR O-ring in the socket. Please apply refrigerant oil to O-ring before use.

Screw-on Type Cupla

# Screw Cupla NCF Type

**Screws on to the male unified thread easily.  
Made up of the nut and body.  
The bearing in the Screw Cupla makes rotation of the nut smooth and reduces damage to the three-terraced-shape lip packing.**

- Employing a three-terraced-shape lip packing enables more stable seal performance opposed to conventional packing and O-rings.
- Withstands a vacuum of up to  $1.3 \times 10^{-1}$ Pa ( $1 \times 10^{-3}$  mmHg) (when connected) making it possible to be used in leak test, vacuum suction and refrigerant charge.
- Select from two standard types of seal materials to be used with fluids for air conditioner and refrigerator production lines. Many models available to suit various thread sizes.
- The nut shape is changed for visual recognition of the seal material used in the Screw Cupla.

### Specifications

Body material	Stainless steel		
Size	For unified thread		
Working pressure	4.5 MPa, 46 kgf/cm <sup>2</sup> , 45 bar, 653 PSI		
Seal material Working temperature range	Seal material	Mark	Working temperature range
	Chloroprene rubber	CR (C308)	-20°C to +80°C
	Hydrogenated nitrile rubber	HNBR (H708)	-20°C to +120°C

### Models and Dimensions (WAF : WAF stands for width across flats.)

When considering using the Screw Cupla NCF Type, refer to the external dimensions of the Cuplas below and verify if the Cupla can be connected to the unified external threads without any interference.

#### Socket

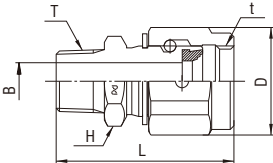
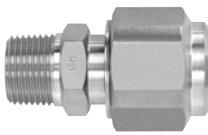
Model	External thread for connection (t)	Model	Dimensions (mm)				
			L	D (WAF)	øB	H (WAF)	T
NCF-7U	7/16-20UNF	NCF-7U-2	44	Hex. 27 × ø29	4.2	Hex. 17	R 1/4
		NCF-7U-3					R 3/8
NCF-10U	5/8-18UNF	NCF-10U-2	46	Hex. 27 × ø29	8	Hex. 19	R 1/4
		NCF-10U-3					R 3/8
NCF-12U	3/4-16UNF	NCF-12U-2	48	Hex. 27 × ø29	10	Hex. 21	R 1/4
		NCF-12U-3					R 3/8
NCF-14U	7/8-14UNF	NCF-14U-2	51	Hex. 32 × ø35	7	Hex. 24	R 1/4
		NCF-14U-3					10
NCF-17U	1 1/16-14UNS	NCF-17U-2	50	Hex. 35 × ø39	7	Hex. 29	R 1/4
		NCF-17U-3					10

### Screw Cupla NCF Type with Plug

- Specify the plug type (SP-V, SP-V-GN), the body material and seal material when ordering.
- The Loctite (medium strength 242) is used as standard for the plug mounting adhesive. Should you require other adhesive or method such as thread seal tape, please specify.

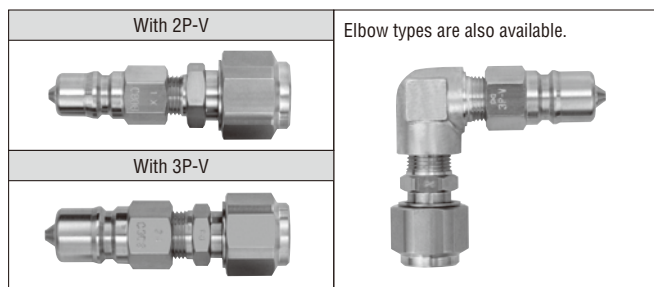

### Three-terraced-shape lip packing

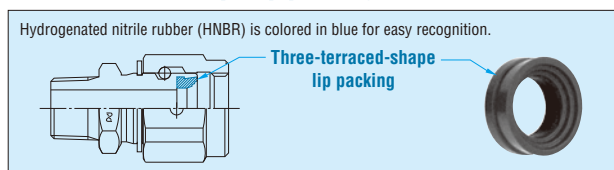

### Identification of the seal material by the Appearance of the Nut

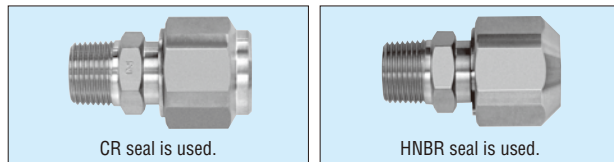

### Work for connection

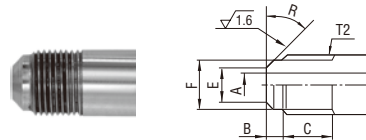

Unified thread: Pursuant to JIS B 8607

Unified thread dimensions (mm)						
øE	øF	R	B	C	øA	T2
5.5	9.2	45° to 46°	3.7	7.6 or more	4.8	7/16-20UNF
8	13.5	45° to 46°	4.8	9.2 or more	7	5/8-18UNF
11	16	45° to 46°	5.5	11.3 or more	10	3/4-16UNF
13.5	19	45° to 46°	6	13.9 or more	12.5	7/8-14UNF
18	24	45° to 46°	6	17.4 or more	16	1 1/16-14UNS

### NCF Cupla with Plug (With Identification Ring)

- When several refrigerants are used on the production line simultaneously, Screw Cupla with colored rings are available for visual recognition and to distinguish the seal material used.

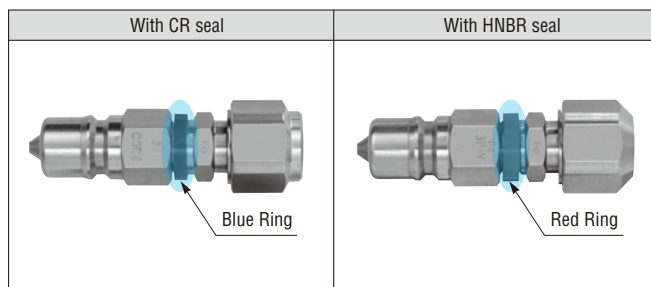

\* Following types are available on request: Long adapter type, 45 degree elbow type, types with round knurled nut, small outer diameter nut or O-ring seal.



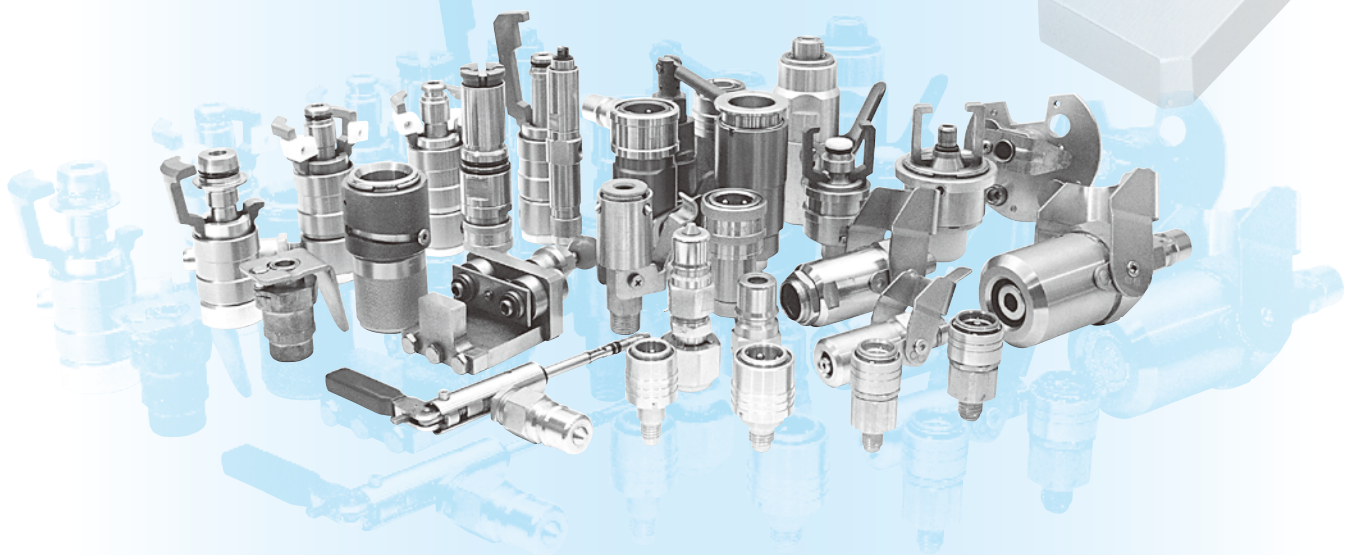

# Pipe Cupla Series

The Pipe Cuplas have been developed for production lines of refrigeration, air conditioning, and automotive industries, and for maintenance services for these products.

Connecting the Cuplas directly to various types of pipes greatly contributes to enhance productivity, labor-saving, and automation in the production lines.

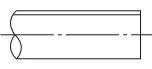
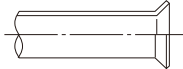

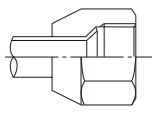
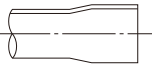
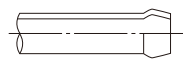
**Connects to various types of pipes and fittings (see the examples below)**

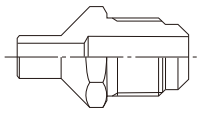
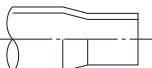
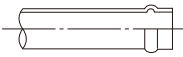
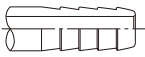
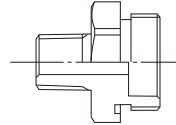
 Straight Pipes	 Flared Pipes	 Bulged Pipes for Heaters	 Flare Nuts
 Expanded Pipes	 Bulged Pipes for Fuel for Engines	 Bulged Pipes for Radiators	 Unified Thread Fittings
 Swaged Pipes	 Spool Pipes for Fuel	 Hose Barbs	 Union Adapters

## Applications

For Charging Work

For Pressure Resistance Test

For Leak Test

For Vacuum Suction Test

For Running Test

## When Considering to Use Pipe Cuplas

- All Pipe Cuplas are made-to-order products that will be designed based on the specifications of customer's work presented by the customer.
- When considering to use Pipe Cuplas, please let us know the following points: pressure, name of fluid, end configuration of Cupla, usage condition, and application, etc.
- All Pipe Cuplas are designed based on the specifications of customer's work. Therefore, it is essential for us to receive the drawing of the work and the work sample from the customer.

## Chuck Lock System for Expanded Pipes and Bulged Pipes

# Pipe Cupla PCHS Type

A special chuck lock system is employed to reduce lock scratches and improve pressure resistance.

Suits for high pressure use.

- Simply push pipes into the Pipe Cupla for connection.
- Locking the outer surface of pipe with the special collet chuck reduces lock scratches and improves pressure resistance.
- A model with sleeve stopper mechanism is also available on request. It prevents accidental disconnection after connecting the Pipe Cupla to pipes.

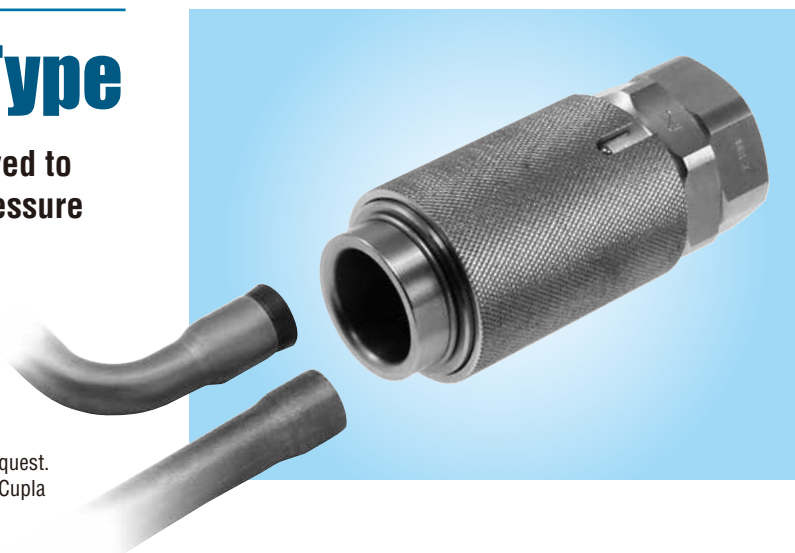

### Applications

Charging Work  
Pressure Resistance Test  
Leak Test

## For Expanded Pipes

# Pipe Cupla PCB Type

Suits for connection and disconnection with expanded pipes and spool pipes.

Easy to handle with the ball lock system using sleeve operation.

- Connects directly to pipes.
- Employs a ball lock system to grip on the outer surface of pipe.
- A model equipped with automatic shut-off valve or sleeve lock mechanism to prevent accidental disconnection is available on request.

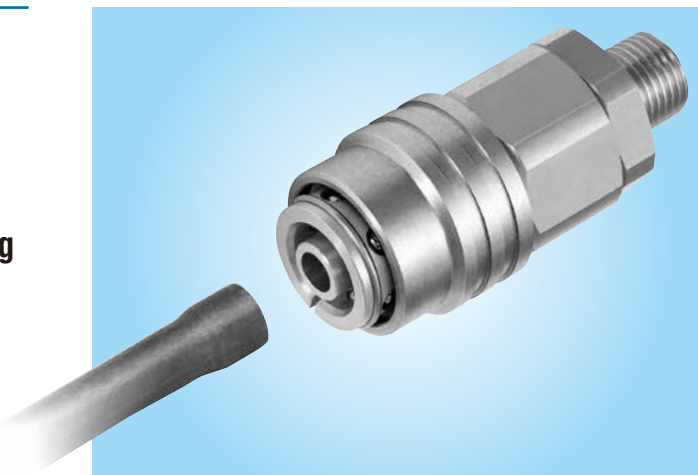

### Applications

Charging Work  
Pressure Resistance Test  
Leak Test  
Vacuum Suction Test



For Bulged Pipes and Spool Pipes

# Pipe Cupla PCBW Type

Suits for connection and disconnection with bulged pipes and spool pipes.  
Resistance to bending forces and vibration is increased by employing a double-row ball lock system.

- Simply push pipes into the Pipe Cupla for connection.
- Employs a double-row ball lock system to grip on the outer surface of pipe securely and to increase resistance to bending forces and vibration.
- A model equipped with automatic shut-off valve or sleeve lock mechanism to prevent accidental disconnection is available on request.



**Applications**

- Charging Work
- Pressure Resistance Test
- Leak Test

For Bulged Pipes and Spool Pipes

# Pipe Cupla PCP Type

Employs a plastic chuck that scarcely scratches pipes.  
Great workability with lighter weight.

- Simply push pipes into the Pipe Cupla for connection.
- A plastic chuck scarcely scratches pipes.
- Improves workability with lighter weight.

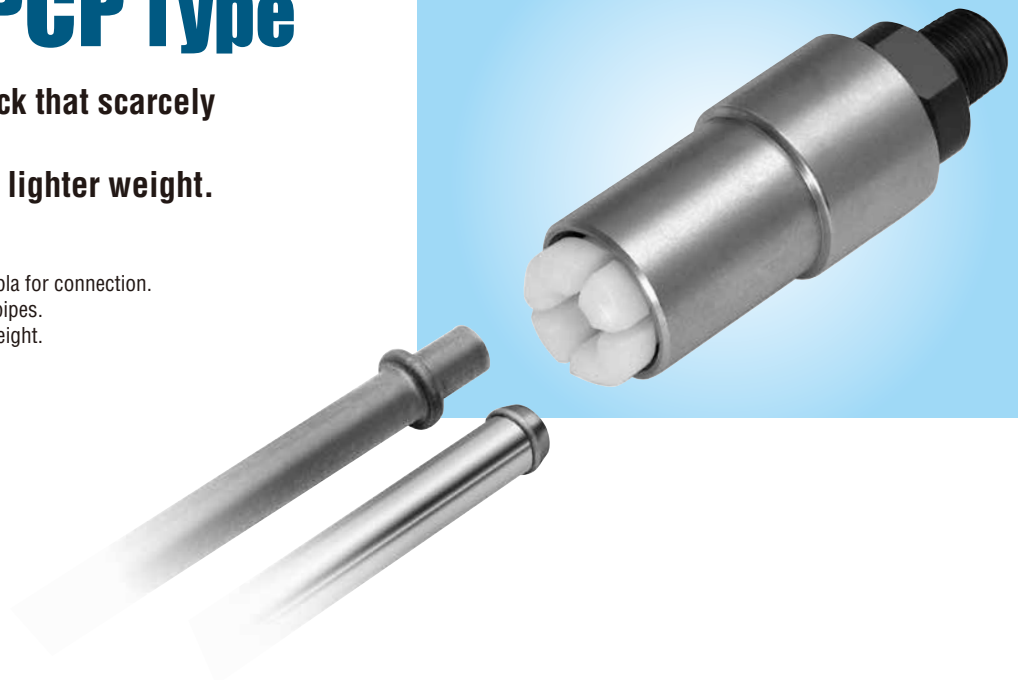

**Applications**

- Charging Work
- Pressure Resistance Test
- Leak Test

## For Straight Pipes

# Pipe Cupla PCBL Type

Suits for connection and disconnection with straight pipes.

Employs a ball lock system to grip on the outer surface of pipe. Improved connection and disconnection with lever operation.

- Connects directly to straight pipes.
- A ball lock system grips on the outer surface of pipe.
- Employs a lever operation system for easy connection and disconnection.
- Employs an aluminum body to lighten the weight and to improve workability.
- Particularly suitable for refrigerator assembly lines.

### Applications

Charging Work  
Pressure Resistance Test  
Leak Test  
Vacuum Suction Test

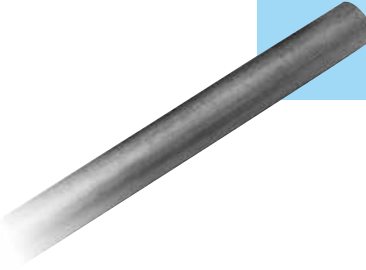
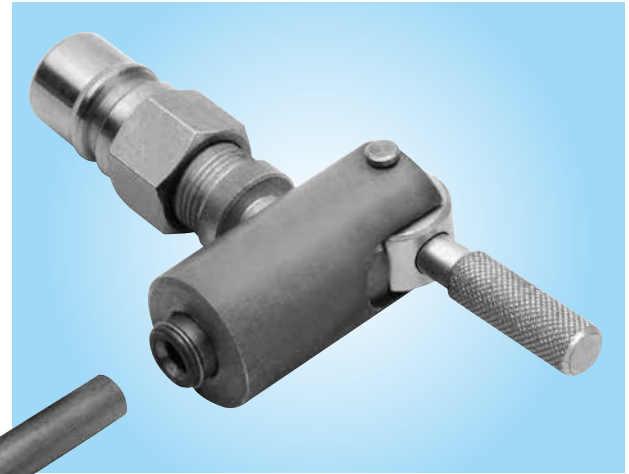

## For Straight Pipes

# Pipe Cupla PCLB Type

Suits for connection and disconnection with straight pipes.

Employs a ball lock system to grip on the outer surface of pipe.

One-handed lever operation facilitates easy connection and disconnection with pipes.

- Connects directly to straight pipes.
- A ball lock system grips on the outer surface of pipe.

### Applications

Charging Work  
Pressure Resistance Test  
Leak Test

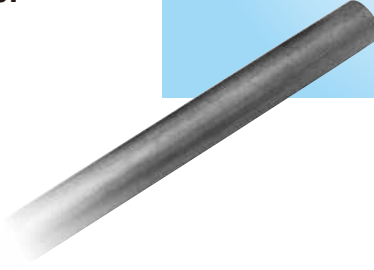

For Straight Pipes

# PCV Type Cupla with Residual Pressure Release Device

Equipped with the residual pressure release device. Lever operation releases the residual pressure for easy disconnection.

- Made up of PCV Type Cupla and the residual pressure release device.
- Raising the lever of the residual pressure release device releases the residual pressure for easy pipe disconnection.
- Suits for refrigerants that require high pressure.

**Applications**

- Charging Work
- Pressure Resistance Test
- Leak Test

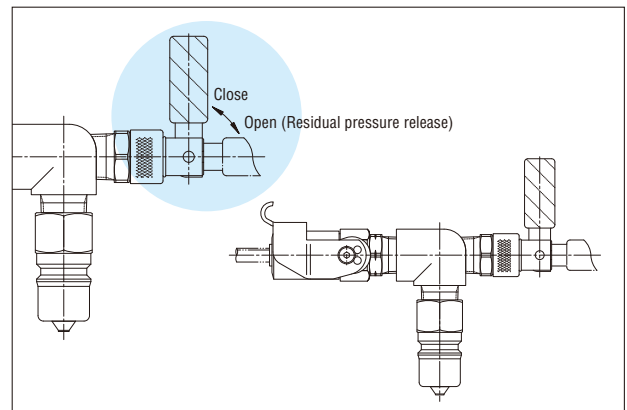
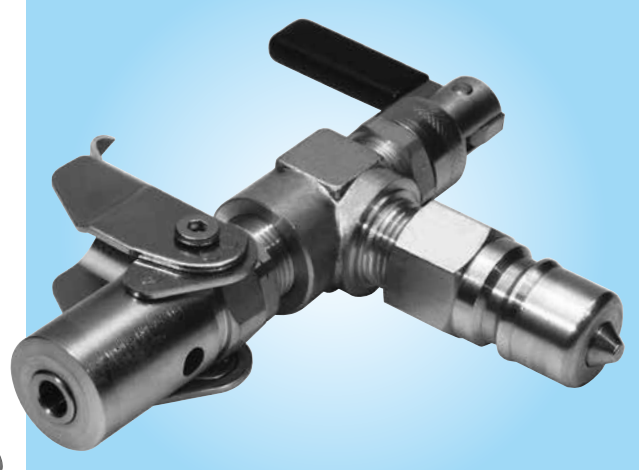

For Pipes with Fittings

# Pipe Cupla PCB Type

Suits for connection and disconnection with pipe fittings. A ball lock system grips on the rear of the hex. nut of pipe fitting upon connection.

- Connects directly to pipe fittings.
- Simply push pipes into the Pipe Cupla for connection. The balls in the Pipe Cupla grip on the rear of the hex. nut of pipe fitting upon connection.

**Applications**

- Charging Work
- Pressure Resistance Test
- Leak Test

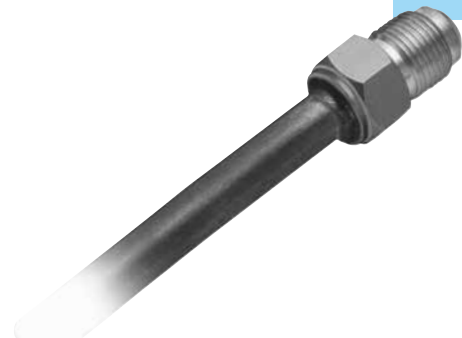

For Straight Pipes and Pipes with Blind Rubber Plugs

## Pipe Cupla PCW Type

Suits for connection and disconnection with straight pipes and pipes with blind rubber plugs. Frequent connection and disconnection can be easily made with the unique lever operation.

- Connects directly to pipes.
- Unique lock design on pipes allows some slight variations in pipe dimensions.

### Applications

Charging Work  
Pressure Resistance Test  
Leak Test

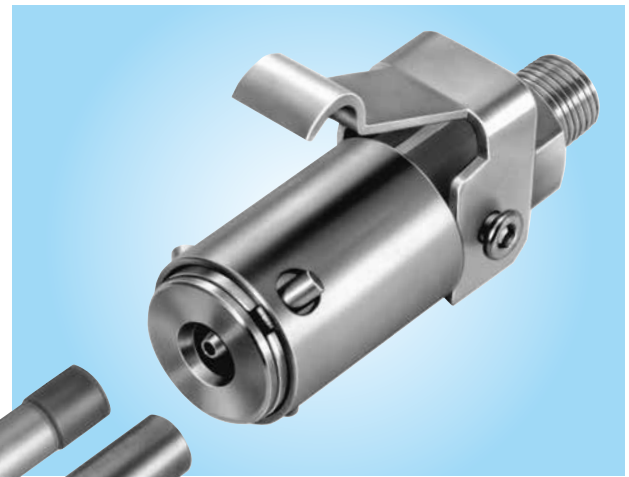
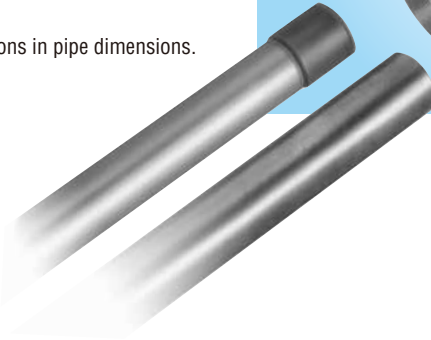

For Large Diameter Straight Pipes

## Pipe Cupla PCA Type

Suits for connection and disconnection with large diameter straight pipes. Employs a special chuck lock system. High pressure resistant version is also available on request.

- Connects directly to large diameter straight pipes.
- Employs a special chuck lock system to grip on the outer surface of pipe.

### Applications

Charging Work  
Pressure Resistance Test  
Leak Test  
Vacuum Suction Test

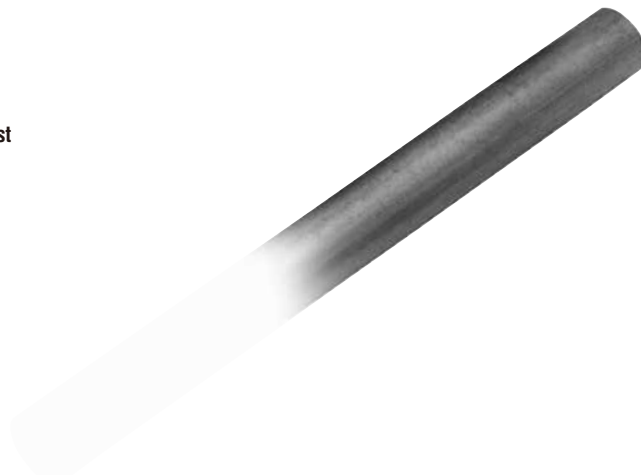

## For Special Pipes

# Pipe Cupla PCD Type

Simply push the Pipe Cupla onto pipe fittings.  
Unique locking mechanism provides outstanding pressure resistance and air-tightness.

- Applicable to pipes with a wide variety of fittings.
- A special clamp locks the outer surface of pipe.
- A model equipped with sleeve lock mechanism to prevent accidental disconnection is available on request.

### Applications

Charging work  
Pressure Resistance Test  
Leak Test  
Vacuum Suction Test

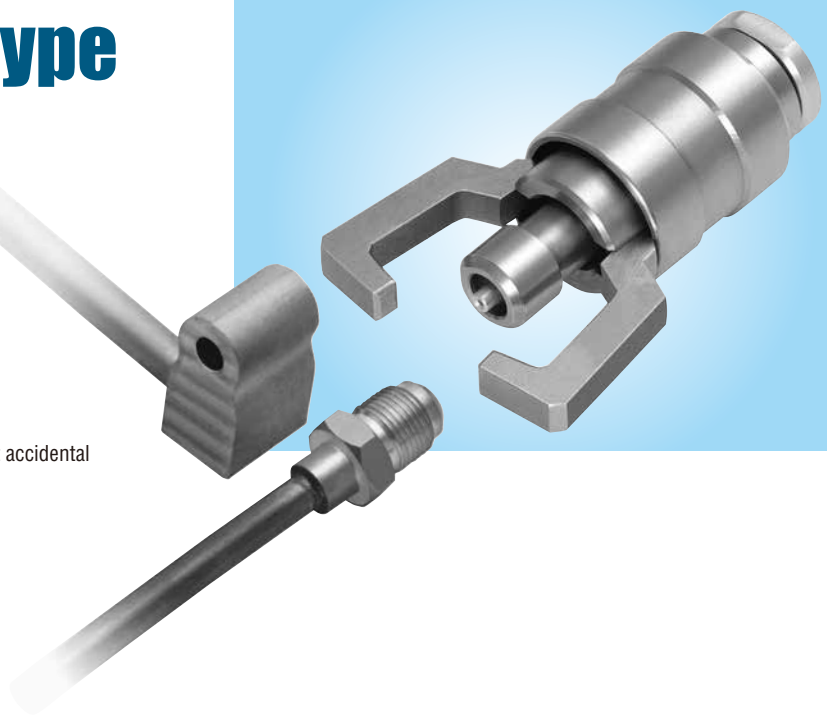

## High Pressure Type for Spool Pipes

# Pipe Cupla PCH Type

Suits for connection and disconnection with spool pipes.  
A special chuck lock system reduces lock scratches and improves pressure resistance.

- Simply push spool pipes into the Pipe Cupla for connection.
- A special chuck lock system is employed to reduce lock scratches and improve pressure resistance.
- A model equipped with sleeve lock mechanism to prevent accidental disconnection is available on request.

### Applications

Charging Work  
Pressure Resistance Test  
Leak Test



## Screw-in Type Cupla

# Screw Cupla PCSI Type

By pushing the Screw Cupla direct to the female thread for connection improves operating efficiency.

- Connects directly to the female thread.
- Simply push the Screw Cupla into the female thread. The safety design ensures an instant and secure grip on the thread with the locking claws upon connection.
- Time-consuming screw tightening work is eliminated, resulting in reduced connection time.

### Applications

Charging Work  
Pressure Resistance Test  
Leak Test

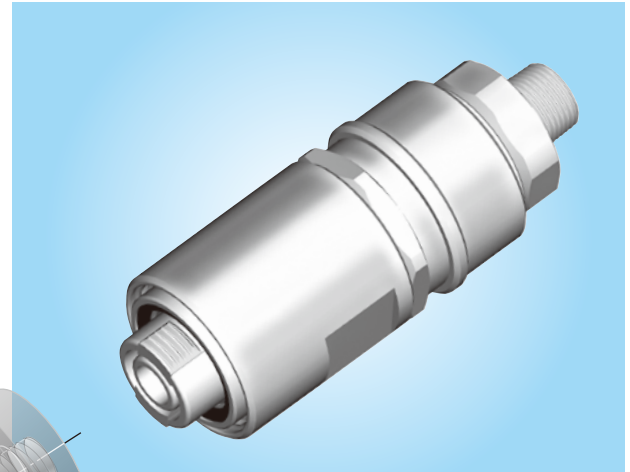
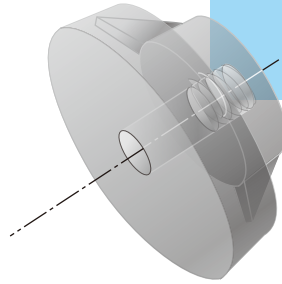

## For Locking at the Leading End of Workpiece from the Inside

# Pipe Cupla PCBI Type

Employs balls to lock at the leading end of workpiece from the inside.  
Greatly improves workability.

- Simply push the back end of the Pipe Cupla toward the workpiece for connection. The balls in the Pipe Cupla lock at the leading end of the workpiece from the inside upon connection.
- Internal pressure is utilized to enhance the sealing performance between the Pipe Cupla and workpiece.
- Time-consuming connection work is eliminated.

### Applications

Charging Work  
Pressure Resistance Test  
Leak Test



For Locking at the Leading End of Workpiece from the Inside

# Pipe Cupla PCI Type

Employs chucks to lock at the leading end of workpiece from the inside.  
Greatly improves workability.

- Simply push the back end of the Pipe Cupla toward the workpiece for connection. The chucks in the Pipe Cupla securely lock at the leading end of the workpiece from the inside upon connection.
- Internal pressure is utilized to enhance the sealing performance between the Pipe Cupla and workpiece.
- Time-consuming connection work is eliminated.

**Applications**

- Charging Work
- Pressure Resistance Test
- Leak Test

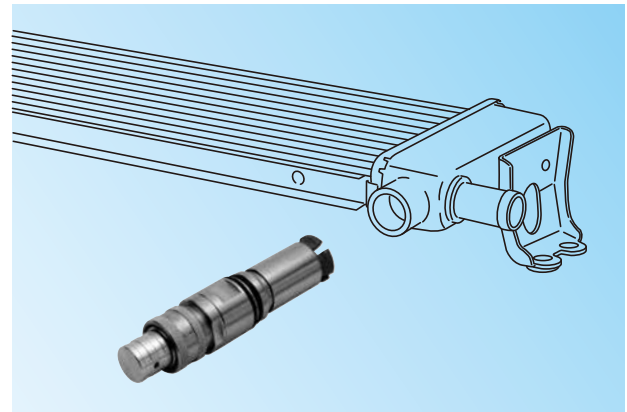
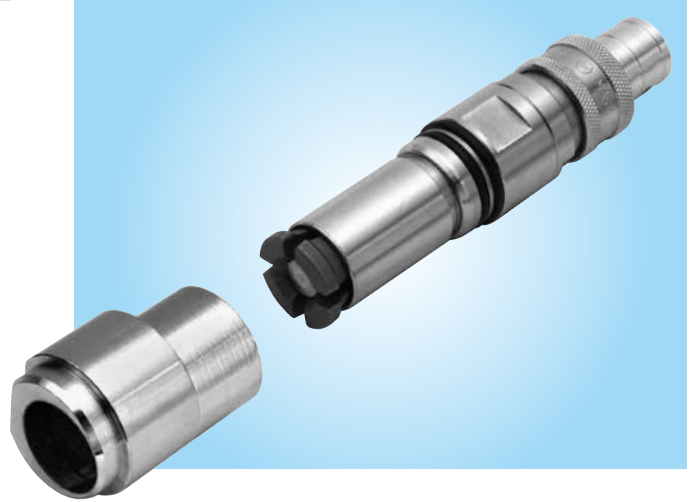

For Pipe Inner Wall Lock

# Pipe Cupla PCIF Type

Employs chucks to grip on the inner wall of pipe.  
Suitable for applications with a small amount of clearance.

- Moving the lever of the Pipe Cupla horizontally completes connection with the pipe.
- Pushing the rod shaped part of the Pipe Cupla into the inside of pipe and moving the lever horizontally activates the chucks to grip on the inner wall of pipe securely.
- Lever operation seals the fluid passage at the inner wall and the leading end of pipe.
- Time-consuming connection work is eliminated.

**Applications**

- Charging Work
- Pressure Resistance Test
- Leak Test
- Vacuum Suction Test

A PCIF type shown below is available on request.

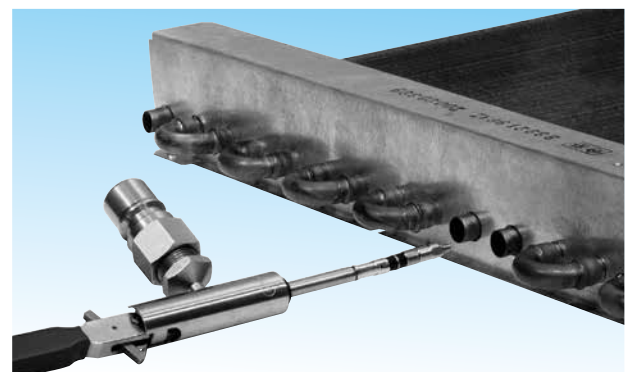
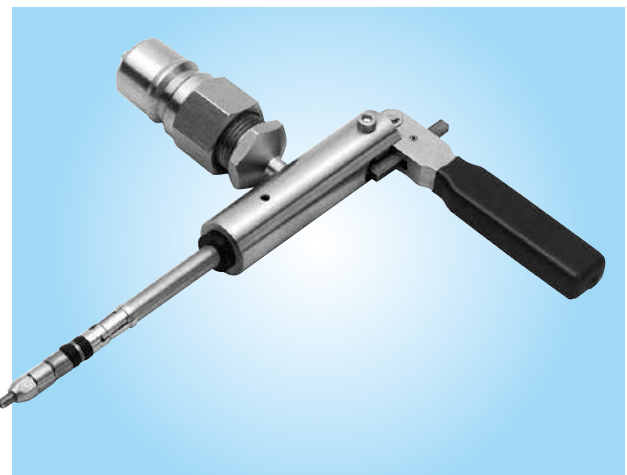

**For Automatic Pipe Disconnection**

# AUTO Cupla APCB Type

**Automatic Pipe Disconnection Type.  
Contributes to energy and labor saving on the  
production line.**

- Simply push pipes into the Auto Cupla for connection.
- Air-driven mechanism is employed in the Auto Cupla to disconnect the pipe automatically.  
When an air pressure of 0.5 to 0.6 MPa (5 to 6 kgf/cm<sup>2</sup>) is applied to section A, the pipe is automatically disconnected.

**Applications**

- Charging Work
- Pressure Resistance Test
- Leak Test

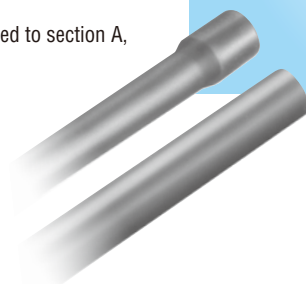
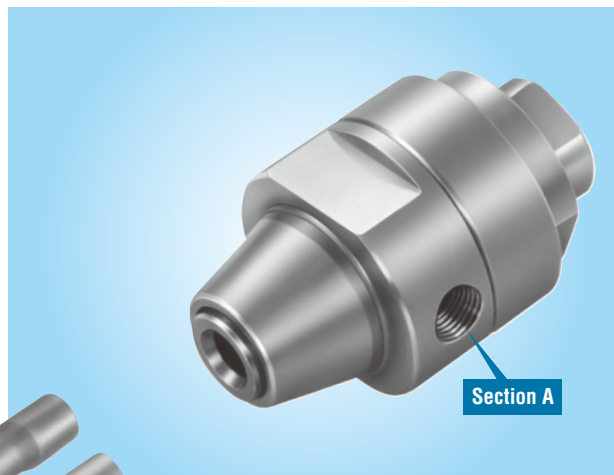

**For Refrigerant Charge Valves Used in  
Car Air conditioner Production Lines**

# PCB Type Cupla for Charge Valves

**Quick connection and disconnection with  
refrigerant charge valves (JRA2009 standard)  
used in car air conditioner  
production lines.**

- Greatly improve workability in charging refrigerants and vacuum suction.

**Applications**

- Charging Work
- Pressure Resistance Test
- Leak Test
- Vacuum Suction Test

Valve built-in types are also available on request.

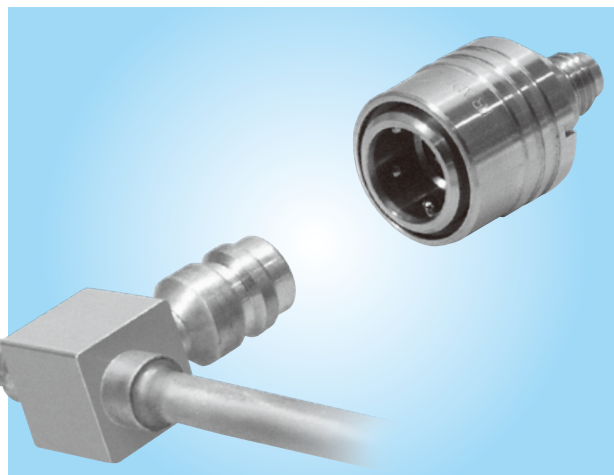
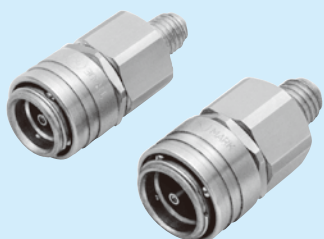

For high pressure use

For low pressure use







# Safety Guide

## Safety Precautions

The safety precautions provide instructions for the safe use of Nitto Cuplas to avoid the potential danger of bodily harm or damage to surrounding property. The safety precautions are categorized under the headings Danger, Warning and Caution, in accordance with the degree of potential hazard to the body or surrounding property, if the Cuplas are used incorrectly.

They are all important notes for safety and must be followed as well as in accordance with International standards #1 and other local safety regulations #2.

#1: ISO 4413, Hydraulic Fluid Power – General rules relating to systems    ISO 4414, Pneumatic Fluid Power – General rules relating to systems

#2: Industrial Health & Safety law (for example)

### **DANGER**

Indicates an imminently hazardous situation which, if not avoided, will result in death or serious injury.

### **DANGER**

Stop using the Cupla immediately if there is any anticipated danger of operation or reduced safety.

### **WARNING**

Indicates a potentially hazardous situation which, if not avoided, could result in death or serious injury.

### **WARNING**

The enclosed safety precautions are only a guideline. When using Nitto Cuplas, you are requested to pay particular attention to possible hazardous situations for the application which are not stated in the safety precautions.

### **CAUTION**

Indicates a potentially hazardous situation which, if not avoided, may result in personal injury or property damage.

## Safety Guide for Refrigeration, Automotive and Air Conditioning Cupla Series

### **WARNING**

- Do not use Cuplas continuously exceeding the rated working pressure.
- Only use Cuplas within the range of the rated temperature. Otherwise the seal may get damaged or deteriorate and cause leakage.
- Do not apply any excessive impact, bend or tension more than is necessary to connect or disconnect Cuplas. It may cause leakage or damage.
- Do not connect or disconnect Cuplas while they are pressurized or residual pressure remains.
- Do not disassemble Cuplas.

### **CAUTION**

- Use a thread sealant on the male taper pipe thread to ensure no leakage.
- The fluid to be used must be compatible with the body and seal material of Cupla.
- Only use Cuplas as quick connecting fluid couplings.
- Only use Cuplas with a combination of Nitto Cuplas.
- Do not use Cuplas in a place where dust or metal dust gets in. It may cause malfunction or leakage.
- May cause malfunction or leakage if paint sticks to Cuplas.
- Install a shut-off valve between the pressure source and Cuplas.
- Do not use Cuplas as a swivel joint.
- Do not connect Cuplas directly to a vibrating or impact device. It may result in reduced lifetime.
- Selecting the wrong type of seal material may cause leakage. In making your selection, check the compatibility of seal and body material with the type of fluid and temperature. As to the use of any special paint or solvent, make thoroughly sure of the material compatibility.
- In cleaning Cuplas, do so in a manner that will not affect the seal and body materials of Cuplas.
- Do not drop Cuplas. It may reduce the performance of the Cuplas.
- Do not use Cuplas continuously at the lowest or highest working temperature.
- Do not exceed the recommended maximum torque when screwing in to the male or female thread of a Cupla for installation. It may cause damage.
- Do not apply any excessive bending, tension or rotation to Cuplas. It may cause leakage or damage.
- Dirt, scratches or damages on the sealing surface may cause leakage.
- The inclusion of foreign matter in the fluid to be used may cause malfunction. Fluid must be cleaned through filters before reaching to Cuplas.
- Do not strike the tip of an automatic shut-off valve with a hammer or a similar tool. It may cause leakage or malfunction. Consult us for an alternative way of releasing the residual pressure.
- Put a Nitto genuine dust cap on the plug after disconnection when there is a possibility of dirt sticking to the plug seal surface.
- Do not exceed the recommended maximum torque when screwing in to the male or female thread of a Cupla for installation. It may cause thread damage.
- As a rule no lubricant is applied to the H.NBR O-ring in the socket prior to shipment. Apply refrigerant oil to the O-ring before use.
- Make sure that there is no burr, deformation and foreign matter on and around the end and insertion port of the pipes before connecting pipes to the Cuplas.
- After connection, try to pull the Cupla and pipe apart to check secure connection.
- When in storage or not in use, do not keep the Cupla levers turned down.
- Be sure to make the connection/disconnection tests and leakage test after having done maintenance on Cuplas.
- Safety precautions differ depending on the types of Cuplas. For further details contact us.
- The dimensions of pipes to be connected with the Cupla must be the ones drawn on drawings, specification sheets, etc.

# Safety Guide

## ⚠ Caution When Selecting Cuplas

### ⚠ DANGER

- Connection to a coupling of another brand may cause imperfect connection or disconnection, reduced air tightness, impaired pressure resistance or durability, reduced flow rate and potentially result in an unexpected accident and therefore must be avoided. Nitto Kohki cannot accept liability for any accident that may result by mixed use with the coupling of another brand. Please be sure to check for our marks on the right side, which are always inscribed on Nitto Kohki Cupla products, when you order and purchase.
- Do not use Cuplas under conditions and environments other than specified in the catalog.

### ⚠ WARNING

- Please consult us prior to use if Cuplas are required for use on machines, equipment or systems (hereafter referred to as "equipment, systems, etc.") for sustaining or controlling human life or body.
- When Cuplas are used for the purpose of ensuring safety, please consult us beforehand.
- The compatibility of the product with specific equipment, systems, etc. must be determined by the person designing the equipment, systems, etc. or the person who decides its specifications based on necessary analysis and test result. The expected performance and safety assurance of the equipment, systems, etc. will be the responsibility of the person who has determined its compatibility with the product.
- If Cuplas are to be used for the following applications, please consult us:
  - Vehicles, aircraft and associated equipment systems that accommodate people
  - Medical facilities or suction equipment that directly affects human body
  - Equipment that directly comes into contact with and runs food, drugs or medicines, drinking water, atomic energy equipment or equipment that ensures safety.
- Selecting the wrong type of seal material may cause a leak. In making your selection, please check the compatibility of the seal material with the type of fluid and temperature used in the application.
- Please consult us prior to selection or use of Cuplas when they are intended for use with corrosive or flammable gases/liquids and/or in atmospheres of these types of gases and liquids.

### Markings



## Warranty and Disclaimer

### Our responsibilities for the defects in our products shall be as follows:

- We shall be responsible for any defects in design, material or workmanship of our products, if it is apparent that such defects are due to reasons solely attributable to us.
- Our responsibilities shall be limited to one of the following, as determined by us:
  - (a) repair of any defective products or parts thereof,
  - (b) replacement of any defective products or parts thereof; or
  - (c) compensation for loss and damages incurred by you, which shall in no case exceed the amount of your purchase price for the defective products.
- We shall in no case be liable for any special, indirect or consequential loss or damages, whether such loss or damages are those arising from work stoppage, impairment of other goods or death or personal injury.

## Performance, Dimensions and Its Limitation

Please note the performance charts and outside dimensions in this catalog do not take into account any tolerances found in mass production. The information is an average, to be a guide for selecting models and to enable technical appraisal by users.

## Beware of Imitations

Recently, similar products which invite misidentification or confusion with Nitto Kohki Cuplas have appeared on the market.

Connection with such a similar product to a Nitto Kohki Cupla may cause:

1. Imperfect connection or disconnection
2. Reduced air tightness
3. Impaired pressure resistance or durability
4. Reduced flow rate

and could result in unexpected accidents.

Therefore, connection other than with a Nitto Kohki Cupla must be avoided.

Please be sure to check for our original marks on the right hand side of this page, which are always inscribed on Nitto Kohki Cupla products, when you order and purchase.

**Note: Nitto Kohki cannot accept any liability for any accident that may occur as a result of using couplings of another brand in conjunction with our own.**

## ⚠ Caution for Custom-made Cuplas

Custom-made Cuplas are products designed and produced based on the specifications presented by the customer.

Prior to actual production, technical documentation presented by us (drawings, specification sheets, etc.) shall be exchanged and approved by the customer.

For the use of the product, the customer shall check the safety and the full compatibility with the equipment used by evaluating its performance thoroughly, under actual operating conditions.

We shall in no case be liable for any loss or damage if the Cupla is used outside the conditions and specifications set out in the original technical documentation.

## ⚠ Caution for Storing Cuplas

- Store Cuplas in a place where no dust or foreign matter gets in. If fluid flows while the dust or foreign matter is present inside Cuplas, the dust or foreign matter may go into the equipment connected to the Cupla and may cause malfunction.
- Store Cuplas indoors away from water or moisture.
- Store Cuplas in a shaded, dry and well-ventilated place.
- Do not to drop Cuplas. It will deform or damage Cuplas.
- If Cuplas are stored or not being used for a long period of time, check their appearance, function and performance before use.

# Special order / Custom-made Cuplas contributing to labor-saving and productivity enhancement in all industries (Here are some of the application examples.)

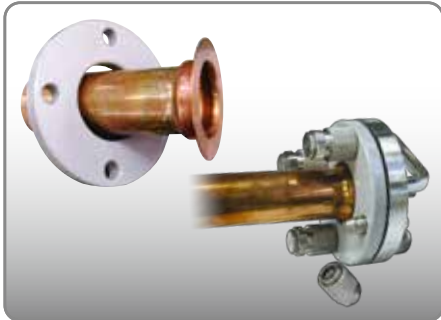

**Leak Test on Large-sized Air Conditioner Pipes**

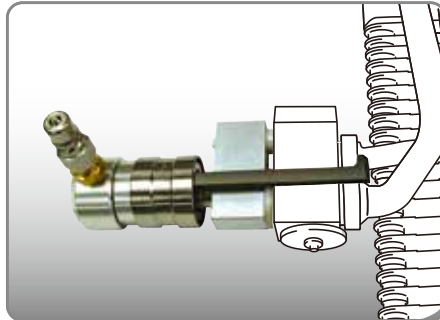

**Helium Leak Test on Car Air Conditioners**



**Pressure Resistance and Leak Test on Special Pipes**

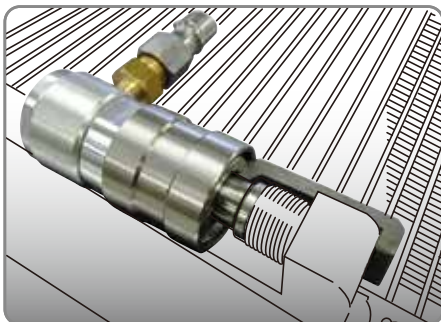

**Helium Leak Test on Condensers**

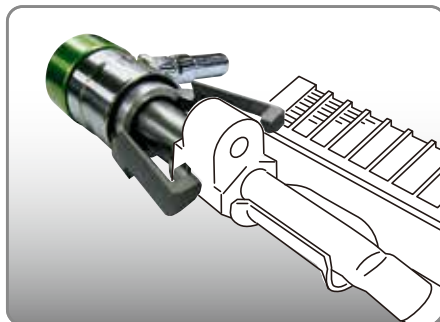

**Helium Leak Test on Car Air Conditioners**

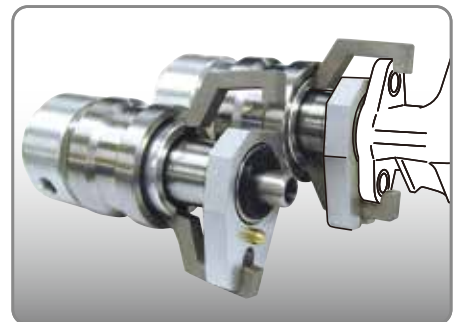

**Helium Leak Test on Car Air Conditioners**

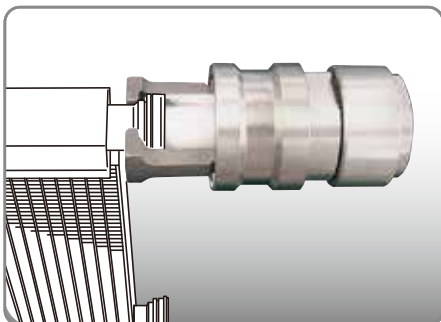

**Helium Leak Test on Car Air Conditioners**



**Helium Leak Test on Heat Exchangers**

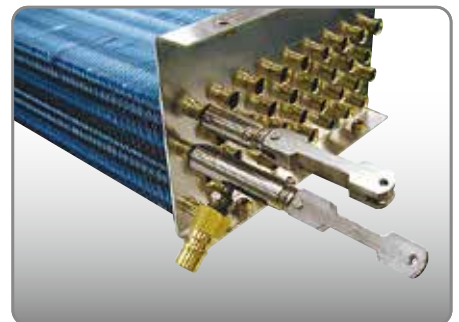

**Helium Leak Test on Heat Exchangers**

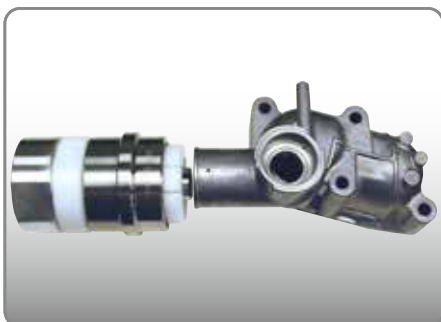

**Engine Bench Test**

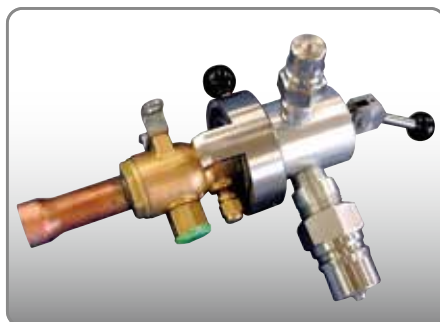

**Helium Leak Test on Package Air Conditioners**



**Helium Leak Test on Condensers**

# From Development to Production, Management and Marketing of “Cuplas”

Nitto Kohki has introduced the “integrated product assurance system” that can respond promptly to “users’ requirements” by covering the range of development, quality control, production and marketing in order to ensure supply of high-performance high-quality “Cuplas”.

## Research and Development

The needs of the time and the latest information are gathered and analyzed, and unique technology is utilized to the challenge for ceaseless development of better Cuplas, Cuplas that suggest new applications.



Headquarters and R & D Laboratory



## Quality Control

The careful selection of materials, painstaking pursuit of machining precision, and strict surveillance process such as severe endurance tests have earned trust for our Cuplas as a global brand.



## Production

High-grade, rationalized, and integrated production system extends from the machining of parts to the assembly and testing of completed products. Robots that we make ourselves for our own plants and many other state-of-the-art facilities that cannot be seen elsewhere have marvelous capacity for mass production. And with them all, we aim to be an establishment of a flexible supply system.



## Marketing

Meticulous marketing activities include advertising in the general industrial press and specialist papers, national and local exhibitions, training sessions, catalogs, promotion videos, other presentation tools and technical data sheets for new launches, and unique yet dynamic campaigns, etc.



## Production Facilities That Assure Our Product Quality

### Production Facilities Assure Flexible Supply System

Large scale production facilities in Tochigi Prefecture, Japan and Ayutthaya, Thailand, having the capability of flexible mass production, are in full operation around the clock and constitute a complete high-grade supply system, from the machining of components to the assembly and testing of finished products, that is forever ready and able to respond to our user’s reliance.

TOCHIGI NITTO KOHKI CO., LTD.



NITTO KOHKI INDUSTRY (THAILAND) CO., LTD.



# Nitto Kohki's Laborsaving Products

Nitto Kohki is capturing the needs of users by introducing to the world not only "Cuplas" quick connect couplings, but also next-generation laborsaving devices, including various "machine tools and hand tools", high precision "Delvo" electric screwdrivers, and linear-motor-driven piston "compressors/vacuum pumps".



## Machines and Tools

### Machines and Tools to Achieve Energy and Labor Savings in Processing Work

Machines and tools are used at various processing sites for such work as cutting, polishing, scaling, drilling and chamfering of steel materials. We have created a product line up of pneumatic, electric and hydraulic machines and tools to match the diversification of processing methods and the conditions of work operations.



## delvo

### High Precision "Delvo" Electric Screwdrivers for Professional Use

NITTO KOHKI "delvo" Electric Screwdrivers are high-quality tools for professional use, with special emphasis on precise control of torque and long life. They apply just the correct amount of torque—with sure, positive control always at your fingertips. They are smooth and shockless in operation, too.



## Linear

### Compressors, Vacuum Pumps and Their Applied Products

MEDO pumps are unique products featuring a linear-motor-driven free piston system. NITTO KOHKI has made available a complete series of air compressors and suction pumps that incorporate this uniquely functional design. These are quite appropriate as air sources or suction power units for various pneumatically operated equipment and apparatus in advanced industries.



บริษัท นานตีอินเตอร์เทรด จำกัด  
**NANDEE INTER-TRADE CO., LTD.**

314, 316, 318, 320, 322 ซอยจันทน์ 32 ถนนจันทน์ แขวงทุ่งวัดดอน เขตสาทร กทม. 10120

- ☎ : 0-2675-8239
- 📞 : @nandeeintertrade
- 📘 : nandeeintertrade
- 🌐 : www.nandee.co.th
- ✉ : [marketing@nandee.co.th](mailto:marketing@nandee.co.th)  
[sales@nandee.co.th](mailto:sales@nandee.co.th)