



HYDRAULIC

Product Lineup Catalog



HYDRAULIC PROCESS DIAGRAM

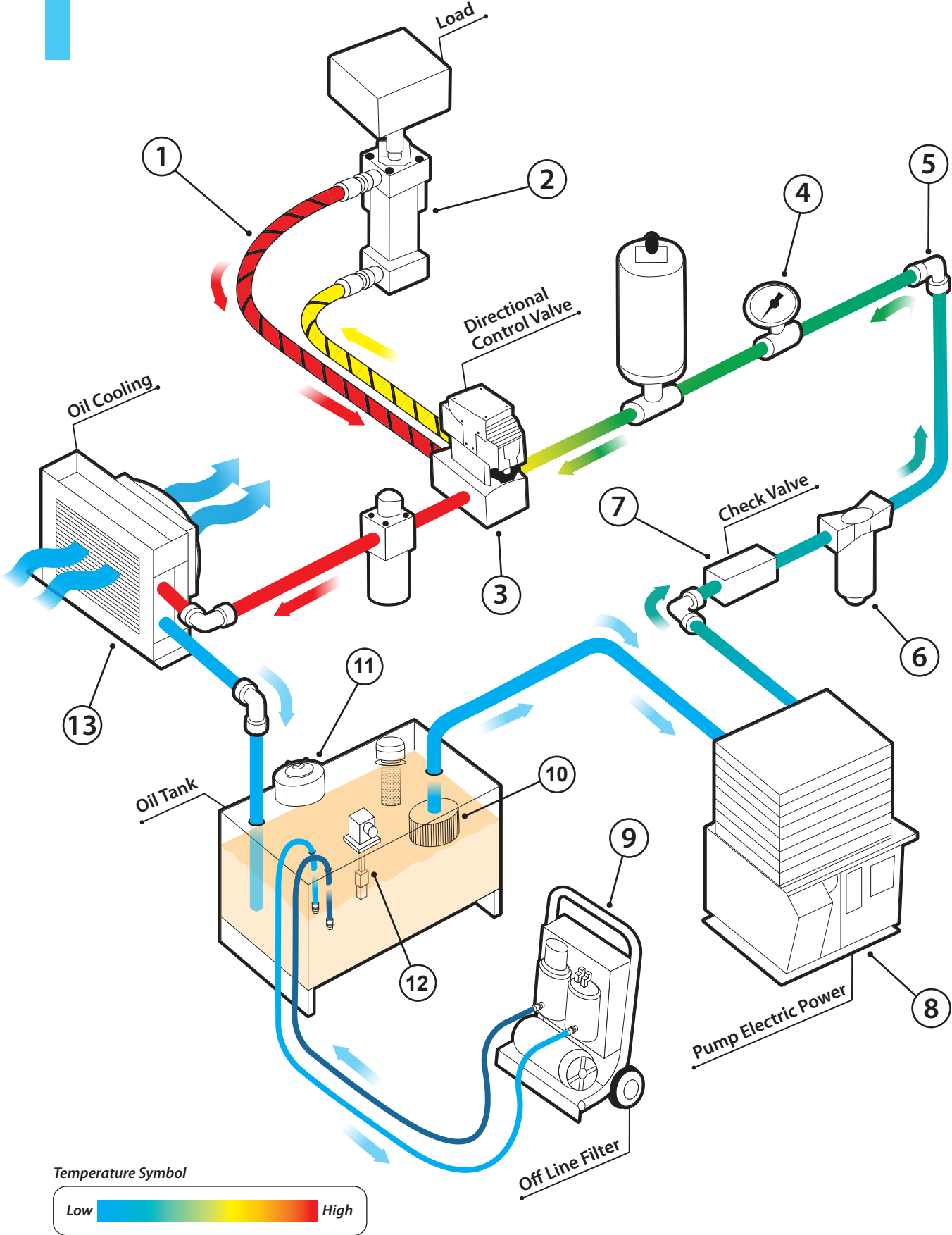

HYDRAULIC PRODUCT LINEUP CATALOG

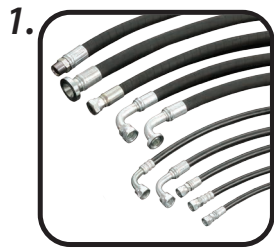

SUMITOMO RIKO
Hydraulic Hose

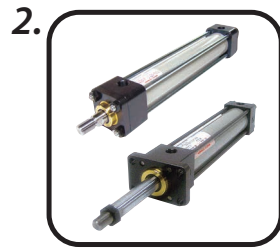

HORIUCHI MACHINERY
Hydraulic Cylinder

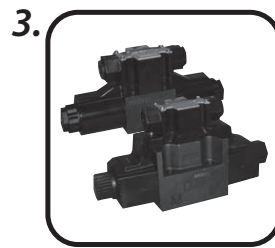

DAIKIN
Directional Control Valve

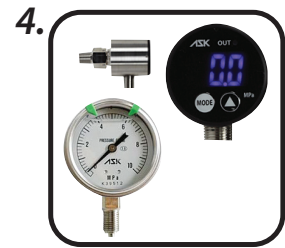

ASK
Measuring Instrument
- Pressure Gauge
- Digital Pressure Switch



IHARA SCIENCE
- Fitting
- Valves
- Piping System



TAISEI KOGYO
Filtrations - Line Filter



ASK
Check Valve

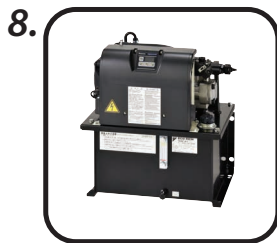

DAIKIN
Inverter - Controlled
Hydraulic Power Unit

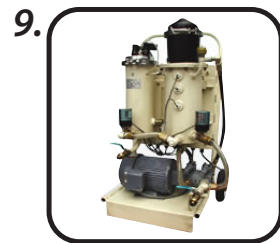

TAISEI KOGYO
Off Line Filter

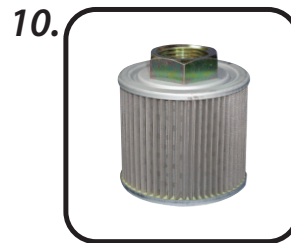

TAISEI KOGYO
Suction Filter



TAISEI KOGYO
Filtrations
- Air Breather
- Fluid Refill Breather

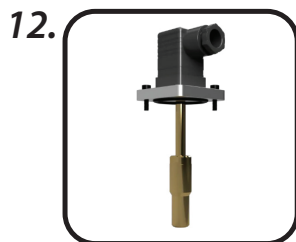

ASK
Temperature Switch



DAIKIN **TAISEI KOGYO**
Oil Cooling Shell And Tube, Air-Cooled

 **3 - 21**

 **TAISEI KOGYO** **23 - 41**

 **43 - 48**

 **51 - 57**

 **SUMITOMO RIKO** **60 - 65**

 **67 - 69**

 **NITTO KOKHI** **70 - 78**



HYBRID HYDRAULIC SYSTEM

ECORICH	3
SUPER UNIT	4
SUPER UNIT [with double pump specification]	5
HIGH-ACCURACY SUPER UNIT	6
SUPER UNIT CASE STUDY	7
THE FUNDAMENTALS OF IPM MOTORS	8

FLUID COOLING UNIT

OIL COOLING UNIT [Circulation type] - AKZ SERIES	9
COOLANT COOLING UNIT [Immersion type] AKJ SERIES	10
COOLANT COOLING UNIT [Circulation type] AKC SERIES	11

HYDRAULIC PART

V SERIES	12
DS SERIES [Compact Single Stage Vane Pump]	13
M SERIES	14
JRB SERIES [Pilot Operated Relief Valve]	15
HDFT SERIES [Throttle Valves / Throttle Valves with Check Valve]	16
KSO SERIES [Solenoid Valve]	17
HDIN SERIES [Inline Check Valve]	18
JCA SERIES [Right-angle Check Valve]	19
MT-02 SERIES [02 Series Stacking Type Port A / B Throttle Valves]	20
MP SERIES	21
MPD SERIES	21

ECORICH

The world's first hybrid hydraulic system that combines hydraulics technology and Daikin motor/inverter technology.



- Power consumption**
 The highly efficient IPM motor surpasses IE4 class to reduce power consumption by an additional 65% compared to a conventional hydraulic unit.
- Oil temperature**
 Suppressing the oil temperature reduces the thermal influence on the machine, improves the environment at the machine site, prevents degradation of hydraulic oil and extends the oil replacement interval.
- Space-saving design**
 A more compact and lightweight unit offers easier installation. All models offer a 9% reduced footprint. The EHU1404/2504 model offers a 40% mass reduction.
- Complies with regulations**
 All models meet CE standards.

Model code		EHU1404-40	EHU2504-40	EHU2507-40	EHU3007-40	EHU3007-40-Y		
Maximum operating pressure	bar	40			70			
Operation pressure adjustment range	bar	15 ~ 40			15 ~ 70			
Maximum flow	L/min	15.2	25.1		28.5			
Operation flow rate adjustment range	L/min	2.5 ~ 15.2	3.5 ~ 25.1		3.5 ~ 28.5			
Motor capacity	equivalent kW	0.75	1.5	2.2	2.8			
Tank capacity	L	18						
Power supply voltage	V	3 ~ 200 V (50 Hz), 200 V (60 Hz), 220 V (60 Hz)				3 ~ 380 V (50 Hz) / 400 V (60 Hz) / 460 V (60 Hz)		
		Permissible voltage fluctuation: ±10%						
Rated current	200V/50Hz	A	6.0	7.0	4.7	10.3	380V / 50Hz	7
	200V/60Hz	A	5.9	7.0	4.5	10.3	400V / 60Hz	6.5
	220V/60Hz	A	5.5	6.7	4.3	9.7	460V / 60Hz	6
No fuse breaker capacity	A	15				10		
External input signal		3 channels, photo coupler insulation, DC 24 V, (maximum of DC 27 V), 5 mA per channel						
External output signal	Digital output	1 channel, photo coupler insulation, open collector output, DC 24 V, 50 mA maximum per channel						
	Contact output	1 channel, relay output, contact capacity: DC 30 V, 1 A (resistance load), 1 common contact						
Usable oil		General petroleum-based hydraulic oil (R&O) / Wear-resistant hydraulic oil • Viscosity grade: ISO VG32 to 68 • Viscosity range: 15 to 400 mm ² /s • Contamination: Within NAS class 10						
Tank oil temperature		0 to 60°C (Recommended operating temperature range: 15 to 50°C)						
Operating ambient temperature		0 ~ 40°C						
Storage ambient temperature		-20 ~ 60°C						
Operating ambient humidity		85% RH maximum (no condensation)						
Waterproof protection rating		IP44						
Installation site		Indoors (Be sure to secure with bolts, etc.)						
Vibration resistance		X direction 4.9 m/s ² Y direction 4.9 m/s ² Z direction 14.7 m/s ² 7.5~100 Hz 2.5 hr						
Altitude		1,000 m maximum						
Standard coating color		Black						
Mass (hydraulic oil excluded)	kg	26			29			

SUPER UNIT

The advanced SUPER UNIT offers several different features to achieve higher performance and energy savings.

- Power consumption**
 Daikin's original high-efficiency IPM motors with inverter technology provides a 50% increase in energy-savings compared to a conventional hydraulic unit.
- Multi-stage pressure/flow rate control**
 The operation panel on the unit features 16 different pressure (P) and flow rate (Q) settings to control the cylinder and ensure shockless operation according to the parameter settings.
- Low operational noise**
 The double pump feature helps the SUPER UNIT achieve an operational noise level of 60 dB(A) (when the pressure is at 206 bar), and less than 73 dB(A) in the operating area.
- Complies with regulations**
 All models meet CE standards.



Function option:

- Communication function**
 This function is available for all models and allows remote control and setting changes through an RS232C serial communication.
- Analogue command input**
- This function is available for single pump type models and enables continuous control of pressures and speeds as required.

NEW MODEL WINTER 2022 NEW MODEL WINTER 2022 NEW MODEL WINTER 2022 NEW MODEL WINTER 2022

Model code	SUT03S 4007-30	SUT06S 6007-30	SUT10S 8007-30	SUT03S 3010-30	SUT03S 1516-30	SUT06S 3016-30	SUT00S 4007-40Y	SUT00S 6007-40Y	SUT00S 8007-40Y	SUT00S 3016-40Y	
Maximum operating pressure	70			100	160		70		160		
Operation pressure adjustment range	15 ~ 70			15 ~ 100	15 ~ 160		15 ~ 70		15 ~ 160		
Maximum flow	39.7	61.1	83.0	25.6	15.2	25.6	39.7	61.1	83	25.6	
Operation flow rate adjustment range	5.3 ~ 39.7	8.7 ~ 61.1	11.6 ~ 83.0	3.4 ~ 25.6	2.4 ~ 15.2	3.4 ~ 25.6	5.3 ~ 39.7	8.7 ~ 61.1	11.6 ~ 83.0	3.4 ~ 25.6	
Motor capacity	3.7	5.0	7.0	3.7		5.0	3.7	5	7	5	
Tank capacity	30	60	100	30		60	-				
Power supply voltage	3 ~ 200 V (50 Hz), 200 V (60 Hz), 220 V (60 Hz)						3 ~ 400 V (50/60Hz)				
	Permissible voltage fluctuation: ±10%										
Rated current	200V/50Hz	A	16.1	22.1	25.5	18.4	15.2	21.4	-		
	200V/60Hz	A	15.8	21.7	24.8	18.4	15.2	21.4	-		
	220V/60Hz	A	14.8	20.2	22.7	16.9	14.6	20.2	-		
	380V	A	-				8.5	11.6	13.4	11.3	
	400V	A	-				7.9	10.9	12.4	10.7	
	480V	A	-				6.8	9.3	10.4	9.3	
No fuse breaker capacity	A	20	30	50	20		30	15	15	20	
External input signal	5 channels, photo coupler insulation, DC 24 V (maximum of DC 27 V), 5 mA per channel										
External output signal	Digital output	2 channels, photo coupler insulation, FET output, DC 24 V, 50 mA maximum per channel									
	Contact output	1 channel, relay output, Contact capacity: DC 30 V, 0.5 A (resistance load), 1 common contact									
Usable oil	General petroleum-based hydraulic oil (R&O) / Wear-resistant hydraulic oil (Refer to Daikin "Oil hydraulic brochure" for the oil in detail) • Viscosity grade: ISO VG32 to 68 • Viscosity range: 15 to 400 mm ² /s • Recommendation is from 20-200 mm ² /s • Contamination: Within NAS class 9 (Within Nas class class10 at 70 bar or less pressure) • Volumetric water content: 0.1% maximum										
Tank oil temperature	0 to 60°C (Recommended operating temperature range: 15 to 50°C)										
Operating ambient temperature	0 ~ 40°C										
Storage ambient temperature	-20 ~ 60°C										
Humidity	85% RH maximum (no condensation)										
Installation site	Indoors (Be sure to secure with bolts, etc.)										
Vibration resistance	Motor: 29.4m/s ² 33.3 Hz X,Y direction 2 hr Z direction 4 hr Controller: 21.6m/s ² 33.3 Hz X,Y direction 2 hr Z direction 4 hr										
Altitude	1,000 m maximum										
Standard coating color	Ivory white (Munsell code 5Y7.5/1)										
Mass (hydraulic oil excluded)	kg	64	97	131	64	68	60	46	56	72	
Other	• Be sure to connect a circuit breaker for all (three) poles and the earth leakage breaker • Make sure that the electrical wiring meets the requirements of European Standard EN60204-1 • Be sure to connect the ground terminal										

SUPER UNIT [with double pump specification]

This SUPER UNIT combines the efficient Daikin IPM motor and double pump switching control technology.

- Power consumption**
 The unit automatically changes the pump combinations, which consist of a single or tandem operation depending on the load condition. At the pressure retained operation, only the low displacement pump operates, saving a significant amount of energy.
- Low operational noise**
 The double pump feature helps the SUPER UNIT achieve an operational noise level of 60 dB(A) (when the pressure is at 206 bar). Adding double phase-differential pumps can reduce the noise level even more.



Double pump system

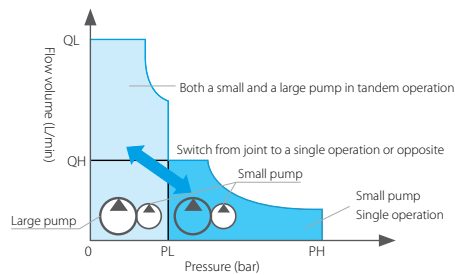
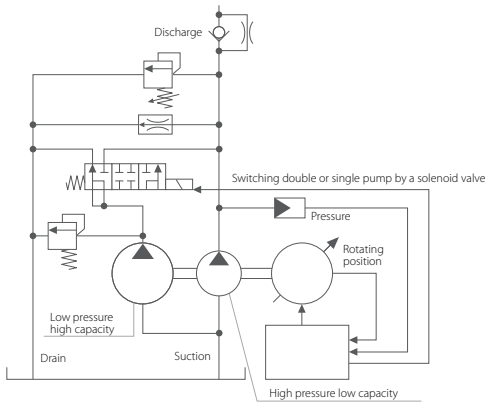

Power consumption \propto Pressure x Flow volume
 Flow volume = Pump capacity x Rotation speed
 Pump capacity is smaller due to a reduction in power consumption during the high pressure retaining operation

NEW MODEL WINTER 2022

Model code	SUT06D 4016	SUT06D 6021	SUT10D 6021	SUT10D 8021	SUT16D 8021	P-SUT20D 11KW	SUT00D 6021-40Y	SUT00D 8021-40Y		
Maximum operating pressure	157	206		206		206	206			
Operation pressure adjustment range	15 ~ 160	15 ~ 206		15 ~ 206		15 ~ 206	15 ~ 206			
Maximum flow	41.0	61.1		83.0		110	61.1	83		
Operation flow rate adjustment range	5.4 ~ 41.0	8.7 ~ 61.1		11.6 ~ 83.0		13.3 ~ 110	8.7 ~ 61.1	11.6 ~ 83.0		
Motor capacity	Equivalent to 3.7		Equivalent to 5.0		Equivalent to 7.0		Equivalent to 11.0			
Tank capacity	60	60	100	100	160	200	-			
Power supply voltage	3 ~ 200V (50 Hz), 200V (60 Hz), 220V (60 Hz)						3 ~ 400V (50/60Hz)			
	Permissible voltage fluctuation: $\pm 10\%$									
Rated current	200V/50Hz	A	17.9	22.7	25.5		38.3	-		
	200V/60Hz	A	17.7	21.7	24.8		37.8	-		
	220V/60Hz	A	16.5	20.2	22.7		34.9	-		
	380V	A	-		-		11.9	13.4		
	400V	A	-		-		10.9	12.4		
480V	A	-		-		9.3	10.4			
No fuse breaker capacity	A	20	30	50		75	15	20		
External input signal	5 channels, photo coupler insulation, DC 24 V (maximum of DC 27 V), 5 mA per channel									
External output signal	Digital output	2 channels, photo coupler insulation, FET output, DC 24 V, 50 mA maximum per channel								
	Contact output	1 channel, relay output, Contact capacity: DC 30 V, 0.5 A (resistance load), 1 common contact								
Usable oil	General petroleum-based hydraulic oil (R&O) / Wear-resistant hydraulic oil (Refer to Daikin "Oil hydraulic brochure" for the oil in detail.) • Viscosity grade: ISO VG32 to 68 • Viscosity range: 15 to 400 mm ² /s (Recommendation is from 20-200 mm ² /s) • Contamination: Within NAS class 9 (Within Nas class class10 at 70 bar or less pressure) • Volumetric water content: 0.1% maximum									
Tank oil temperature	0 to 60°C (Recommended operating temperature range: 15 to 50°C)									
Operating ambient temperature	0 ~ 40°C									
Storage ambient temperature	-20 ~ 60°C									
Humidity	85% RH maximum (no condensation)									
Installation site	Indoors (Be sure to secure with bolts, etc.)									
Vibration resistance	Motor: 29.4m/s ² 33.3 Hz X,Y direction 2 hr Z direction 4 hr Controller: 21.6m/s ² 33.3 Hz X,Y direction 2 hr Z direction 4 hr									
Altitude	1,000 m maximum									
Standard coating color	Ivory white (Munsell code 5Y7.5/1)									
Mass (hydraulic oil excluded)	94	99	112	133	145	360	58	72		
Other	• Be sure to connect a circuit breaker for all(three)poles and the earth leakage breaker • Make sure that the electrical wiring meets the requirements of European Standard EN60204-1 • Be sure to connect the ground terminal									

HIGH-ACCURACY SUPER UNIT

This analogue command input/high-accuracy type SUPER UNIT offers extended operating for high pressure and flow rates.

- High voltage/high flow rate**
 This extension offers PQ control with even greater accuracy than conventional SUPER UNITS.
- Power consumption**
 Helps industrial machinery such as presses and general industrial machines achieve high performance, smooth operation and higher energy efficiency.
- High accuracy**
 Achieving stable servo control in response to analog input voltages over a range from low pressure (1%)/flow rate (1%) to the maximum pressure/flow rate.
- Operational commands**
 All models allow selection of the input type as the analogue command input type or 8-PQ digital command input type using a parameter.



HYBRID HYDRAULIC SYSTEM

Model list

Flow rate / pressure combinations other than those given in the model list below are also available. Please consult with a Daikin expert when considering your options.

Maximum discharge rate	SUPER UNIT (analogue command input, high-accuracy type)									
	Pressure/flow rate model list									
300 L / min			SUT00D30021 200 / 400 V		37	The numbers indicate the nominal motor capacity (kW).		SUT00D30028 200 / 400 V		37
260 L / min			SUT00D26021 200 / 400 V		37			SUT00D22028 200 / 400 V		37
220 L / min								SUT00D22028 200 / 400 V		37
200 L / min	SUT00S20018 400 V	22	SUT00D20021 200 / 400 V		15	SUT00D20025 200 / 400 V		22		
150 L / min	SUT00S15018 200 / 400 V	15	SUT00D15021 200 / 400 V		15					
130 L / min	SUT00S13018 400 V	15	SUT00S13021 400 V	15	SUT00D13021 200 / 400 V	15	SUT00D13025 400 V	15		
80 L / min	SUT00S8018 200 / 400 V		SUT00D8021 200 / 400 V		11	SUT00D8025 400 V		11		
50 L / min			SUT00S5021 200 / 400 V		11	SUT00S5025 200 / 400 V		15		
30 L / min	SUT00S3018 200 V	7	SUT00D3021 200 / 400 V		7					
Maximum operating pressure	176 bar		206 bar		250 bar		280 bar			

CASE STUDIES

SUPER UNIT CASE STUDY

Improving the efficiency of press machines

A conventional hydraulic unit that works continuously during the pressure retaining period can lead to higher energy consumption. With a SUPER UNIT, the system can reduce the rotational speed of the motor during the pressurising process to lower power consumption and save energy costs.

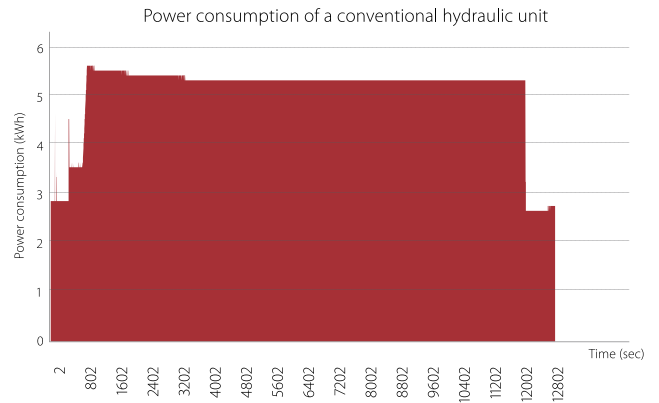

Comparison of power consumption

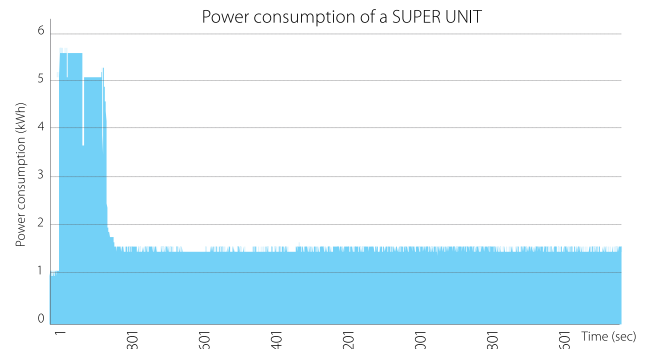
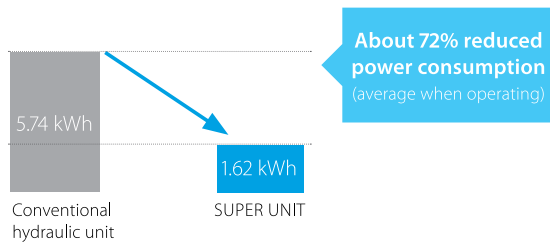

		Model	Pressure	Motor capacity	Tank capacity
Before	Conventional hydraulic unit	Tandem gear pump	125 bar	5.5 kW	200 L
After	SUPER UNIT	SUT10D6021	125 bar	Equivalent to 5.0 kW	100 L

Cost down by energy-saving effect for one year: \$ 4,620

*CO₂ gas reduction for one year: 18.3 t down

ECORICH-R CASE STUDY

Improving the efficiency of machining centres

Daikin technologies optimised every facet of the ECORICH-R to attain higher energy savings than a conventional hydraulic unit. The efficient operating system of the ECORICH-R reduces overall energy consumption and provides better control of the oil temperature to prevent damage and extend the service life of the oil.

Comparison of power consumption

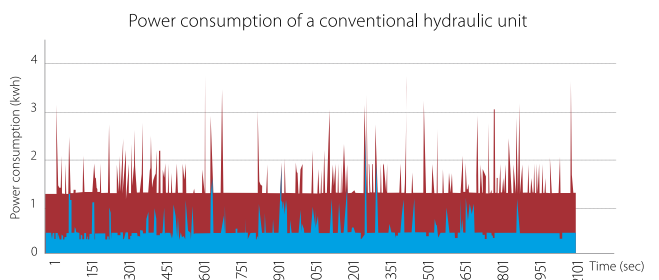
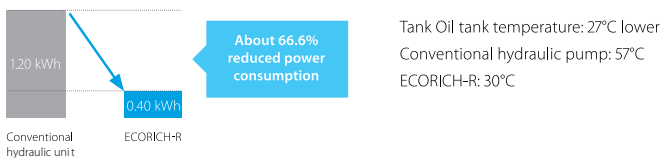

		Model	Pressure	Tank capacity
Before	Conventional hydraulic unit	Piston pump	65 bar	10 L
After	ECORICH-R	EHU30R-M0701	65 bar	10 L

THE FUNDAMENTALS OF IPM MOTORS

A rare-earth permanent magnet deeply positioned in the rotor generates magnet torque (attraction/repulsion between coil and permanent magnet) and reluctance torque (coil attracts iron). This electromagnetic structure attains high torque for the highest possible efficiency.

Structure of a conventional AC servo motor

Surface permanent magnet (SPM) motor

The lengths of the magnetic field lines at the south and north poles are equivalent, which means there's no rotational force or reluctance force generated.

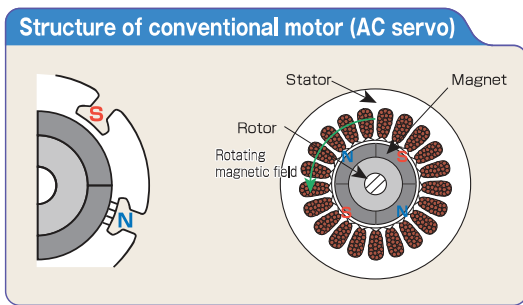

Structure of a Daikin IPM motor

IPM motor drive system

The magnetic field lines at the south pole side are longer than the north side. Similar to how a stretched rubber band contracts, the magnetic field lines at the south pole will try to shorten. As a result, a rotational force will occur due to the reluctance torque moving in a counterclockwise direction (see the arrow in the illustration).

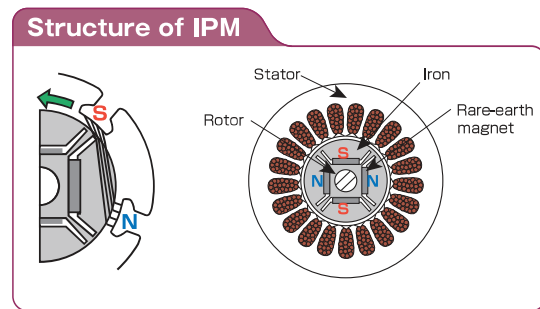

OIL COOLING UNIT APPLICATION

The full cooling unit range

Customers can choose a cooling unit based on the liquid the machine uses and installation preferences.

The application and design policy determine the liquid a unit can use. Most machines use oil, water or coolant, which is why Daikin offers several different types of cooling units to meet every type of need.

Daikin also offers two different types of machines: a circulation type and an immersion type. The circulation type unit contains a heat exchanger inside of a cooling unit. In comparison, the immersion type includes a heat exchanger below the unit and install on the top of tank for a smaller installation footprint.

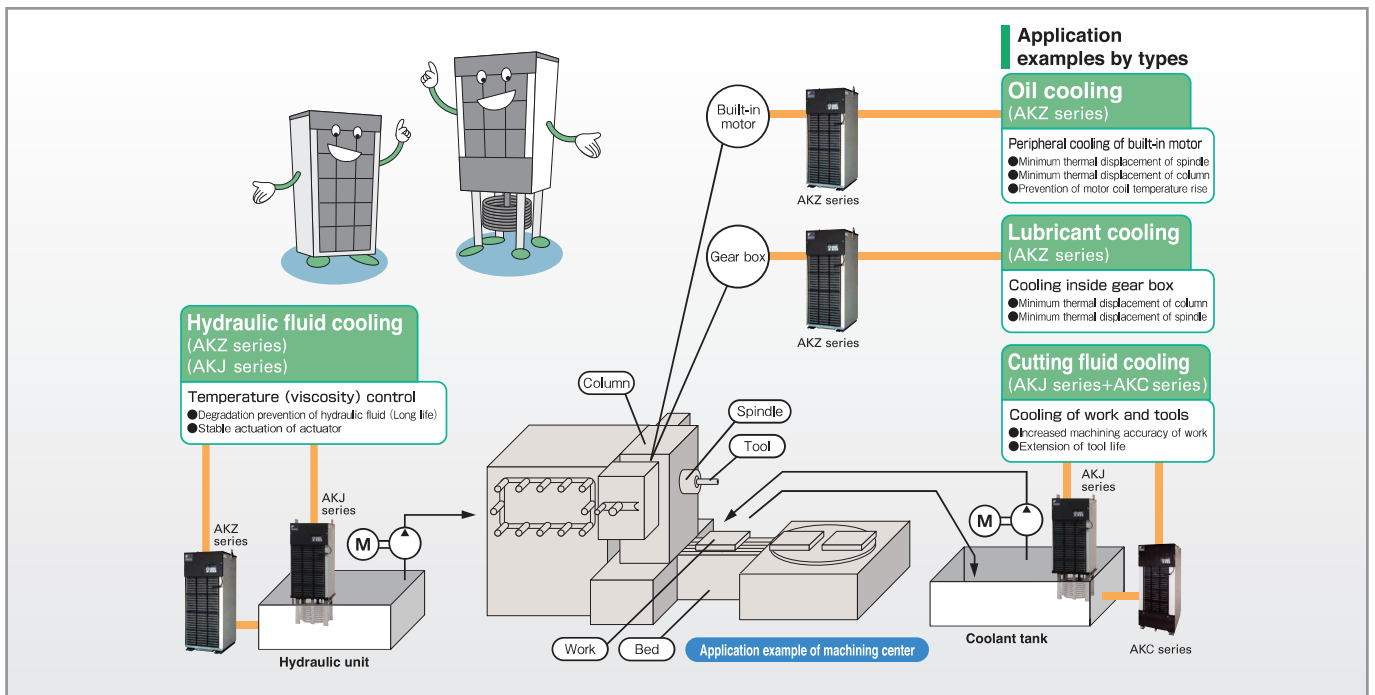

OIL COOLING UNIT - AKZ SERIES

[Circulation type]

- High-accuracy temperature control with Daikin inverter.
- Greater energy- savings performance. Reduction of approximately 45%
- Expansion of cooling capacity control range
- Low-noise operation in the low-load range



FLUID COOLING UNIT

9 series

Model Code		AKZ149				AKZ329				AKZ439				
Oil cooling unit horsepower	(HP)	0.5				1.2				1.5				
Cooling capacity (50/60Hz)	kW	1.3/1.4				2.8/3.2				3.8/4.3				
Circuit voltage	Main circuit	3-Phase AC 200/200-220V 50/60Hz												
	Operating circuit	DC12/24V												
Max. power consumption Max. consumption current	200V 50Hz	0.90kW/3.9A	1.29kW/4.1A	0.90kW/3.9A	*1	1.36kW/4.9A	1.49kW/4.8A	1.36kW/4.9A	*1	1.80kW/6.6A				*1
	200V 60Hz	0.91kW/3.6A	1.32kW/4.2A	0.91kW/3.6A		1.43kW/4.8A	1.61kW/5.2A	1.43kW/4.8A		1.88kW/6.4A				
	220V 60Hz	0.91kW/3.5A	1.43kW/4.2A	0.91kW/3.5A		1.43kW/4.6A	1.72kW/5.0A	1.43kW/4.6A		1.88kW/6.1A				
Outside dimensions (HxWxD)	mm	650x360x440	950x360x440	810x360x535	950x360x440	775x360x440	1075x360x440	965x360x535	1075x360x440	875x360x440	1175x360x440	1065x360x535	1175x360x440	
Compressor (Totally enclosed DC swing type)		Equivalent to 0.4kW				Equivalent to 0.75kW				Equivalent to 1.1kW				
Oil pump (Theoretical discharge rate)	L/min	12/14.4								24/28.8				
Refrigerant control		Compressor revolutions by inverter + Opening of electric expansion valve												
Mass	kg	51	78	68	87	56	83	73	92	64	91	81	100	
Items to be prepared by custome	Molded-case circuit breaker (Rated current) A	10 (Required for types other than - B type)												

Model Code		AKZ569				AKZ909					
Oil cooling unit horsepower	(HP)	2.0				3.0					
Cooling capacity (50/60Hz)	kW	5.0/5.6				8.0/9.0					
Circuit voltage	Main circuit	3-Phase AC 200/200-220V 50/60Hz									
	Operating circuit	DC12/24V									
Max. power consumption Max. consumption current	200V 50Hz	2.22kW/7.7A		2.50kW/8.4A		*1	4.25kW/13.6A				*1
	200V 60Hz	2.30kW/7.6A		2.57kW/8.1A			4.30kW/13.5A				
	220V 60Hz	2.30kW/7.3A		3.00kW/8.9A			4.28kW/13.0A				
Outside dimensions (HxWxD)	mm	1110x470x560	1375x470x580	1410x470x560	1360x470x590	1220x560x680	1485x560x700	1520x560x680	1470x560x659		
Compressor (Totally enclosed DC swing type)		Equivalent to 1.5kW				Equivalent to 2.2kW					
Oil pump (Theoretical discharge rate)	L/min	30/36									
Refrigerant control		Compressor revolutions by inverter + Opening of electric expansion valve									
Mass	kg	82	115	100	145	97	132	122	175		
Items to be prepared by custome	Molded-case circuit breaker (Rated current) A	15 (Required for types other than - B type)				20 (Required for types other than - B type)					

Options and their combinations

Option symbol	With breaker	Compliance with CE	With heater	With tank
-B	✓			
-C		✓		
-H			✓	
-T				✓

COOLANT COOLING UNIT - AKJ SERIES

[Immersion type]

This compact unit is versatile to suit installation on the tank while delivering the same high energy performance.

- A cooler mounted directly on the coolant tank (circulation pump not included).
- Superior energy-saving performance.
- Design is even more compact than the top-class unit in the industry.
- Enhanced support for shallow tanks with the reduced cooling coil depth.
- An extended cooling capacity range.



9 series

Model code		AKJ189	AKJ359	AKJ459	AKJ569	AKJ909	AKJ1509
Oil cooling unit horsepower	HP	0.5	1.2	1.5	2.0	3.0	5.0
Cooling capacity (50/60Hz)	kW	1.6 / 1.8	3.2 / 3.5	4.2 / 4.5	5.0 / 5.6	8.0 / 9.0	15.0 / 15.0
Compressor (Hermetic DC swing type)		Equivalent to 0.4 kW	Equivalent to 0.75 kW	Equivalent to 1.1 kW	Equivalent to 1.5 kW	Equivalent to 2.2 kW	Equivalent to 3.7 kW
Refrigerant		R-410A					
Power voltage	Main circuit	3-phase AC 200/200-220 V 50/60 Hz					
	Operation circuit	DC12/24 V					
Max. power consumption	200 V / 50 Hz	0.82 kW / 3.3 A	1.37 kW / 5.2 A	1.46 kW / 5.6 A	2.77 kW / 9.4 A	3.38 kW / 10.8 A	5.40 kW / 17.3 A
Max. current consumption	200 V / 60 Hz	0.83 kW / 3.2 A	1.38 kW / 5.1 A	1.48 kW / 5.4 A	2.72 kW / 9.2 A	3.43 kW / 10.7 A	5.37 kW / 16.9 A
	220 V / 60 Hz	0.83 kW / 3.0 A	1.39 kW / 4.8 A	1.48 kW / 5.1 A	2.83 kW / 8.9 A	3.43 kW / 10.2 A	5.40 kW / 15.7 A
External dimensions H x W x D	mm	920 x 360 x 440	1,045 x 360 x 440	1,200 x 360 x 440	1,440 x 470 x 500	1,615 x 560 x 620	1,960 x 735 x 725
Mass	kg	38	44	50	72	89	140
Items prepared by the customer	Moulded-case circuit breaker (Rated current)	10 (Required for types other than -B)			15 (Required for types other than -B)	20 (Required for types other than -B)	30 (Required for types other than -B)
	Device other than moulded-case circuit breaker	Tank, supply pump, float switch, return filter, water strainer					

Options and their combinations

Option symbol	With breaker	Compliance with CE	With heater	Voltage Type (1) AC 220 • 230	Voltage Type (2) AC 380 • 400 • 415 V	Voltage Type (3) AC 440 • 460 • 480 V
-B	✓					
-C		✓				
-H			✓			
-046				✓		
-047	✓				✓	
-048	✓					✓

COOLANT COOLING UNIT - AKC SERIES

[Circulation type]

This unit is an easy retrofit for existing tanks and features an enhanced evaporator to prevent clogging.

- High-accuracy temperature control with Daikin inverter.
- Greater energy- savings performance.
- Design meets the latest environmental regulations.
- Easy maintenance for end users.
- Durable against oil mist and dust.



FLUID COOLING UNIT

9 series

Model code		AKC359	AKC569
Oil cooling unit horsepower	HP	1.2	2.0
Cooling capacity (50 / 60 Hz)	kW	3.5 / 3.5	5.6 / 5.6
Compressor (Hermetic DC swing type)		Equivalent to 0.75 kW	Equivalent to 1.5 kW
Refrigerant		R-410A	
Power voltage	Main circuit	3-phase AC 200 / 200-220 V 50/60 Hz	
	Operation circuit	DC12 / 24 V	
Max. power consumption	200 V / 50 Hz	1.17 kW / 4.2 A	1.78 kW / 6.2 A
	200 V / 60 Hz	1.22 kW / 4.3 A	1.87 kW / 6.3 A
	220 V / 60 Hz	1.21 kW / 4.1 A	1.86 kW / 6.1 A
External dimensions HxWxD	mm	995 x 450 x 560	1,200 x 470 x 670
Mass	kg	83	100
Moulded-case circuit breaker (builtin)	A	10	15

Options and their combinations

Option symbol	Compliance with CE	With heater	Unit with pump
-C	✓		
-H		✓	
-200			✓
-CH	✓	✓	
C200	✓		✓
H200		✓	✓
K200	✓	✓	✓

DAIKIN

V SERIES

- **Low noise**
Low noise operation over the entire pressure range has been realized in each series.
- **High efficiency**
Fluid temperature rise can be reduced due to the smaller power loss. This means that the tank can be designed in a small size.
- **High reliability**
High responsivity, high stability, and long life make it possible to increase the reliability of the main machine.



HYDRAULIC PART : PISTON PUMP

Nomenclature

• Pressure compensator control

※ - V ※ ※ A ※ ※ ※ - ※ ※ ※ ※
 1 2 3 4 5 12 15 16 17

• Combination control (pressure feedback method)

※ - V ※ ※ C ※ ※ R H X - ※ ※ ※ ※
 1 2 3 4 7 8 12 13 15 16 17

• Combination control (solenoid operated method)

※ - V ※ ※ C ※ ※ R J ※ X - ※ ※ ※ ※
 1 2 3 4 7 8 12 13 14 15 16 17

• Dual pressure control

※ - V ※ ※ D ※ ※ R ※ X - ※ ※ ※ ※
 1 2 3 4 9 10 12 14 15 16 17

• Power-match control

※ - V ※ ※ SA ※ ※ ※ ※ - ※ ※
 1 2 3 4 6 11 12 15 16

- 1 Applicable fluid code**
No designation : Petroleum-based hydraulic fluid
W : Water-glycol hydraulic fluid
F : Phosphate ester hydraulic fluid
- 2 Model No.**
V: V series piston pump
- 3 Pump capacity**
8: 8.0 cm³/rev
15: 14.8 cm³/rev
23: 23.0 cm³/rev
38: 37.7 cm³/rev
50: 51.6 cm³/rev
70: 69.8 cm³/rev
- 4 Control method I**
A: Pressure compensator control
C: Combination control
D: Dual pressure control
SA: Power-match control

- 5 6 Pressure adjustment range**
- 7 9 Low pressure adjustment range**
- 8 10 High pressure adjustment range**
- 11 FC valve differential pressure**
A: 0.7 MPa {7 kgf/cm²}
B: 1.4 MPa {14 kgf/cm²}
C: 2.1 MPa {21 kgf/cm²}
- 12 Direction of rotation, when viewed from the shaft end**
R: Clockwise (rightward)
L: Counterclockwise (leftward)

*The direction of rotation (rightward or leftward) cannot be changed.
- 13 Control method II**
H: Pressure feedback method
J: Solenoid operated method

- 14 Voltage code for the solenoid valve**
A: AC 100 V (50/60 Hz), AC 110 V (60 Hz)
B: AC 200 V (50/60 Hz), AC 220 V (60 Hz)
N: DC 12 V
P: DC 24 V
- 15 Piping direction**
No designation: Axial port
X: Side port
- 16 Design No.**
20: Pump model V8, V50
95: Pump model V15, V38
30: Pump model V23
<When control method I is A, CH, or SA>
35: Pump model V23
<When control method I is CJ or D>
60: Pump model V70
- 17 Control method III**
No designation: Without remote control system
RC: With remote control system

Specifications

Model No.	Theoretical discharge rate cm ³ /rev	Maximum operating pressure MPa (kgf/cm ²)	Permissible rotational speed min ⁻¹	Discharge rate adjustment range 1800 min ⁻¹ ℓ/min		Mass (Control method A) kg	
				Axial port	Side port	Axial port	Side port
V8	8.0	7 { 70}	500 to 1800	2 to 14.4		-	8.9
V15	14.8	21 {210}	500 to 1800	4.5 to 26.6	7.5 to 26.6	12.8	14.5
V15 (Type Y)	14.8	7 { 70}	500 to 1800	4.5 to 26.6		13.5	
V23	23.0	25 {250}	500 to 1800	12 to 41.4		18.4	21.5
V38	37.7	25 {250}	500 to 1800	34 to 68	36.5 to 68	24.4	26
V50	51.6	21 {210}	500 to 1800	0 to 93		-	50
V70	69.8	21 {210}	500 to 1800	13 to 126		-	55

DS SERIES

[Compact Single Stage Vane Pump]

- **Low noise**
Large suction port reduces the suction resistance and realizes low-noise operation.
- **High efficiency**
The cushion plate system keeps the side clearances constant at all times and maintains stable high efficiency without burn or wear even in the high-speed range.
- **Low pulsation**
The cam ring minimizes the fluctuation of the discharge rate and achieves quiet operation sound and stable performance with little pulsation.



Nomenclature

※ - DS ※※ P - 20 - ※
 1 2 3 2 4 5

- 1 Applicable fluid code**
 No designation: Petroleum-based hydraulic fluid, water-glycol hydraulic fluid
 Water/oil emulsion type hydraulic fluid
 F: Phosphate ester hydraulic fluid

- 2 Model No.**
 DS_P: Compact single stage vane pump

- 3 Pump capacity code**
 11: DS11 type
 12: DS12 type
 13: DS13 type
 14: DS14 type

- 4 Design No.**
 (The design No. is subject to change)

- 4 Direction of rotation, when viewed from the shaft end**
 No designation: Clockwise (rightward)
 L: Counterclockwise (leftward)

*The direction of rotation (rightward or leftward) cannot be changed.

Specifications

Model No.	[Condition] Input rotational speed: 1800 min ⁻¹ , Fluid used: equivalent to ISO VG32, Fluid temperature: 40°C									
	Discharge rate ℓ/min				Shaft input kW					
	0.4 MPa {4 kgf/cm ² }	3 MPa {30 kgf/cm ² }	5 MPa {50 kgf/cm ² }	7 MPa {70 kgf/cm ² }	0.4 MPa {4 kgf/cm ² }	1 MPa {10 kgf/cm ² }	3 MPa {30 kgf/cm ² }	5 MPa {50 kgf/cm ² }	7 MPa {70 kgf/cm ² }	
DS 11P	5.0	4.5	4.1	3.9	0.15	0.28	0.55	0.82	1.1	
DS 12P	7.7	7.2	6.7	6.5	0.20	0.40	0.75	1.12	1.5	
DS 13P	12.6	11.8	11.5	11.0	0.25	0.50	1.05	1.55	2.1	
DS 14P	22.1	21.2	20.5	20.0	0.35	0.77	1.65	2.50	3.4	

M SERIES

- These are motor pumps that integrate a V series piston pump and an electric motor in one body.



Nomenclature

- Pressure compensator control

※ - M ※ ※ A ※ ※ - ※ ※ - ※ ※ - ※ ※ - ※ ※ E
1 2 3 4 5 15 17 12 16 18 19 20

- Combination control (pressure feedback method)

※ - M ※ ※ C ※ ※ H X - ※ ※ - ※ ※ - ※ ※ - ※ ※ E
1 2 3 4 7 8 13 15 17 12 16 18 19 20

- Combination control (solenoid operated method)

※ - M ※ ※ C ※ ※ J X - ※ ※ - ※ ※ - ※ ※ - ※ ※ E
1 2 3 4 7 8 13 14 15 17 12 16 18 19 20

- Dual pressure control

※ - M ※ ※ D ※ ※ X - ※ ※ - ※ ※ - ※ ※ - ※ ※ E
1 2 3 4 9 10 14 15 17 12 16 18 19 20

- Power-match control

※ - M ※ ※ SA ※ ※ ※ - ※ ※ - ※ ※ - ※ ※ E
1 2 3 4 6 11 15 12 16 18 19 20

- 1 Applicable fluid code**
No designation: Petroleum-based hydraulic fluid
W: Water-glycol hydraulic fluid F: Phosphate ester hydraulic fluid
- 2 Model No.** M: M series motor pump
- 3 Pump capacity**
8: V 8 (8.0 cm³/rev) 15: V15 (14.8 cm³/rev)
23: V23 (23.0 cm³/rev) 38: V38 (37.7 cm³/rev)
- 4 Control method I**
A: Pressure compensator control C: Combination control
D: Dual pressure control SA: Power-match control
- 5 6 Pressure adjustment range**
- 7 9 Low pressure adjustment range**
- 8 10 High pressure adjustment range**
- 11 FC valve differential pressure**
A: 0.7 MPa { 7 kgf/cm² } B: 1.4 MPa { 14 kgf/cm² }
C: 2.1 MPa { 21 kgf/cm² }
- 12 Motor output code**
- 13 Control method II**
H: Pressure feedback method J: Solenoid operated method
- 14 Voltage code for the solenoid valve**
A: AC 100 V (50/60 Hz), AC 110 V (60 Hz)
B: AC 200 V (50/60 Hz), AC 220 V (60 Hz)
N: DC 12 V P: DC 24 V
- 15 Piping direction**
No designation: Axial port X: Side port
Y: Suction port: Flange
Discharge port: Taper pipe threads

- 16 Design No.**
60: Pump model M8 (50 when **12** Motor output code = 05)
100: Pump model M15
70: Pump model M23
80: Pump model M38
- 17 Control method III**
No designation: Without remote control system
RC: With remote control system
- 18 Voltage specifications**
1: 200 V (50/60 Hz), 220 V (60 Hz)
4: 400 V (50/60 Hz), 440 V (60 Hz)
- 19 Terminal box position**
No code: Top
R: Right
- 20 Paint color** E: Daikin standard colors

JRB SERIES

[Pilot Operated Relief Valve]

JIS graphic symbols for hydraulic system

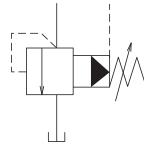

- Achieves stable pressure control over a wide range of flow rates and also works as a safety valve.
- The main circuit pressure can be controlled remotely by connecting a relief valve for remote control to the vent port.
- The vent port can be used to provide the function of an unload valve.
- High-vent type units are available as options.

Nomenclature

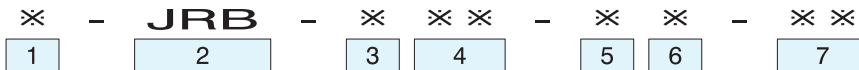

- 1 Applicable fluid code**
No designation: Petroleum-based hydraulic fluid, water-glycol hydraulic fluid
F: Phosphate ester hydraulic fluid
- 2 Model No.**
JRB: J series pilot operated relief valve
- 3 Connections**
G: Gasket mount type
T: Screw connection type
F: Flange connection type
- 4 Nominal diameter**
06: 3/4, 10: 1 1/4, 16: 2
- 5 Pressure adjustment range**
1: Up to 7 MPa {Up to 70 kgf/cm²}
3: Up to 21 MPa {Up to 210 kgf/cm²}
- 6 Vent type code**
No designation: Low-vent type
V: High-vent type
- 7 Design No.**
12: Nominal diameter 16 (2)
13: Nominal diameter 06 (3/4), 10 (1 1/4)

Specifications

Model code	Nominal diameter	Pressure adjustment range MPa {kgf/cm ² }	Maximum flow rate ℓ / min	Mass kg
JRB-G06-1-13	3/4	Up to 7 {Up to 70}	170	6
JRB-G06-3-13		Up to 21 {Up to 210}		
JRB-T06-1-13		Up to 7 {Up to 70}		4.6
JRB-T06-3-13		Up to 21 {Up to 210}		
JRB-F06-1-13		Up to 7 {Up to 70}		
JRB-F06-3-13		Up to 21 {Up to 210}		
JRB-G10-1-13	1 1/4	Up to 7 {Up to 70}	380	9
JRB-G10-3-13		Up to 21 {Up to 210}		
JRB-T10-1-13		Up to 7 {Up to 70}		8.5
JRB-T10-3-13		Up to 21 {Up to 210}		
JRB-F10-1-13		Up to 7 {Up to 70}		
JRB-F10-3-13		Up to 21 {Up to 210}		
JRB-F16-1-12	2	Up to 7 {Up to 70}	700	20
JRB-F16-3-12		Up to 21 {Up to 210}		

Model code	Pressure change MPa {kgf/cm ² } per handle revolution
JRB-※※※-1	2.1 {21}/revolution
JRB-※※※-3	5.2{52}/revolution

Sub-plate model code

- The sub-plate is not provided with the valve. Order it separately as required by specifying the model code given in the table below.

Model code	Nominal diameter	Connection port diameter	Mass kg
JRB-06M	3/4	Rc 3/4	3.5
JRB-06M08		Rc1	
JRB-10M	1 1/4	Rc1 1/4	6.5
JRB-10M12		Rc1 1/2	

Accessories

Connections	Model No.	Hexagon socket head cap bolt	Quantity	Tightening torque N·m {kgf·cm}
Gasket mount type	JRB-G06	M16 x 85	4	250 to 300 {2500 to 3000}
	JRB-G10	M18 x 90	2	322 to 402 {3220 to 4020}
		M18 x 110	2	
Flange connection type	Flang (JIS B 2291 SSA), O-ring, mounting bolts			

HDFT SERIES

[Throttle Valves/Throttle Valves with Check Valve]

- Well balanced structure for pressure enables easy operation of the handle even at a high pressure.
- The compact design minimizes the installation space.
- Facilitates fine adjustment of the flow rate.

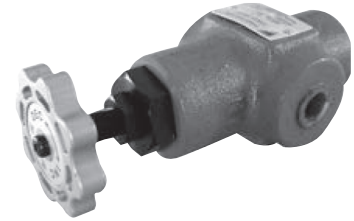

JIS graphic symbols for hydraulic system

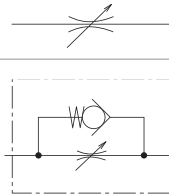

Nomenclature



1 Applicable fluid code

No designation: Petroleum-based hydraulic fluid, water-glycol hydraulic fluid
 F: Phosphate ester hydraulic fluid

2 Model No.

HDFT: H series throttle valve

3 Check valve code

No designation: Without check valve
 C : With check valve

4 Connections

G: Gasket mount type
 T: Screw connection type
 F: Flange connection type

5 Nominal diameter

03 : 3/8
 06 : 3/4
 10 : 1 1/4
 16 : 2

Specifications

Model code	Nominal diameter	Maximum operating pressure MPa {kgf/cm ² }	Maximum control flow rate ℓ/min	Check valve Cracking pressure MPa {kgf/cm ² }	Mass kg	
HDFT(C)-G03	3/8	21 {210}	30	0.2 {2}	2.7	
HDFT(C)-T03					1.5	
HDFT(C)-G06	3/4		75		0.15 {1.5}	4.2
HDFT(C)-T06						3.6
HDFT(C)-F06				9.5		
HDFT(C)-G10	1 1/4		190	0.2 {2}	11	
HDFT(C)-T10		9.4				
HDFT(C)-F10		11				
HDFT(C)-F16	2	470	0.2 {2}	21		

Sub-plate model code

•The sub-plate is not provided with the valve. Order it separately if required by specifying the model code given in the table below.

Model code	Nominal diameter	Connection port diameter	Mass kg
HDFT-03M	3/8	Rc 3/8	1.7
HDFT-06M	3/4	Rc 3/4	3
HDFT-10M	1 1/4	Rc 1 1/4	8

Accessories

Connections	Model No.	Hexagon socket head cap bolt	Quantity	Tightening torque Nm {kgf/cm ² }
Gasket mount type	HDFT(C)-G03	M10 x 70	4	48 to 63 {480 to 630}
	HDFT(C)-G06	M10 x 80	4	48 to 63 {480 to 630}
	HDFT(C)-G10	M12 x 45	6	92 to 122 {920 to 1220}
Flange connection type	Flange (JIS B 2291 SSA), O-ring, mounting bolts.			

KSO SERIES

[Solenoid Valve]

- These models realize high-pressure large-f low-rate control at 35 MPa {350 kgf/cm²} and 100 ℓ/min (G02) or 160 ℓ/min (G03).
- They are best suited to integration into European Safety Standard (CE) compliant equipment since they have dust-/water-proof properties that satisfy the IEC Pub529 IP65 ingress protection grade.

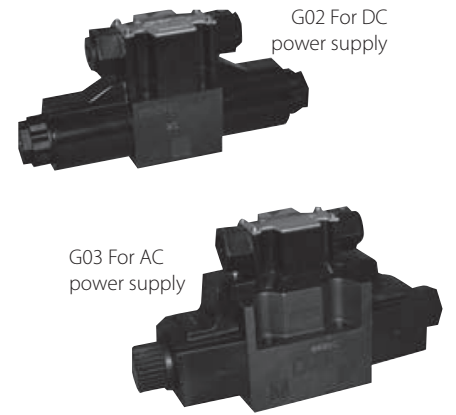

Nomenclature



- | | |
|--|--|
| <p>1 Applicable fluid code
No designation: Petroleum-based hydraulic fluid
H : Water-glycol hydraulic fluid applicable only to G03(G02 accepts water-glycol hydraulic fluid with no designation.)
F : Phosphate ester hydraulic fluid</p> <p>2 Model No.
KSO : K series solenoid valve</p> <p>3 Connections
G : Gasket mount type</p> <p>4 Nominal diameter
02: ¼ 03: ⅜</p> <p>5 Spool type (See the model table)</p> | <p>6 Spool operating method
C: Spring center type
A: Spring offset type (with A solenoid)
B: Spring offset type (with B solenoid)
N: No-spring type (without detent, applicable only to KSO-G02)
D: No-spring type (with detent)</p> <p>7 Voltage code (See the solenoid specification table)</p> <p>8 Design No.
20: Nominal diameter 03 (⅜)
30: Nominal diameter 02 (¼)</p> <p>9 Option code (See the option code table)</p> <p>10 Auxiliary spool type (See the model table)</p> |
|--|--|

Model No.	Nominal diameter	Maximum operating pressure MPa (kgf/cm ²)	Maximum flow rate ℓ/min	Permissible back pressure MPa (kgf/cm ²)	Maximum switching frequency Times/minute			External coating protection
					AC, DC	With rectifier	With built-in surge killer DIN connector type with lamp	
KSO-G02	¼	35 {350}	100	17.5 {175}	240	120	100	IEC Pub529 IP65
KSO-G03	⅜	(25 {250})	160 (DC), 130 (AC)	16 {160}			60	

Solenoid specification table

●KSO-G02

Voltage code	Power supply voltage	starting current A	Holding current A	Holding power W	Permissible voltage fluctuation %	Voltage code	Power supply voltage	starting current A	Holding current A	Holding power W	Permissible voltage fluctuation %
A	AC 100 V (50Hz)	2.42	0.51	21.5	80 to 110	M	AC 230 V (50Hz)	1.05	0.22	21.5	80 to 110
	AC 100 V (60Hz)	2.14	0.37	18	90 to 121		AC 230 V (60Hz)	0.93	0.16	18	90 to 120
	AC 110 V (60Hz)	2.35	0.44	22.5	82 to 110						
B	AC 200 V (50Hz)	1.21	0.26	21.5	80 to 110	N	DC 12 V	-	2.35	28.2	90 to 110
	AC 200 V (60Hz)	1.07	0.19	18	90 to 121	P	DC 24 V	-	1.22	29.2	90 to 110
	AC 220 V (60Hz)	1.18	0.22	22.5	82 to 110	Q	DC 48 V	-	0.61	29.3	90 to 110
C	AC 110 V (50Hz)	2.2	0.46	21.5	80 to 110	R	DC 100 V	-	0.35	34.8	90 to 110
D	AC 220 V (50Hz)	1.1	0.23	21.5	80 to 110	S	DC 110 V	-	0.32	35	90 to 110
J	AC 240 V (50Hz)	1.01	0.21	21.5	80 to 110	T	DC 200 V	-	0.18	35.4	90 to 110
	AC 240 V (60Hz)	0.89	0.15	18	90 to 120	U	DC 220 V	-	0.15	33.6	90 to 110
K	AC 120 V (50Hz)	2.02	0.43	21.5	80 to 110	E	AC 100 V with rectifier	-	0.38	33.5	90 to 110
	AC 120 V (60Hz)	1.78	0.31	18	90 to 120	F	AC 110 V with rectifier	-	0.34	32.8	90 to 110
L	AC 115 V (50Hz)	2.1	0.44	21.5	80 to 110	G	AC 200 V with rectifier	-	0.2	36.8	90 to 110
	AC 115 V (60Hz)	1.86	0.32	18	90 to 120	H	AC 220 V with rectifier	-	0.17	34	90 to 110

HDIN SERIES

[Inline Check Valve]

- Installed in a hydraulic line parallel to the line, the check valve opens when the pressure reaches the cracking pressure, allowing fluid to flow only in one direction and blocking the flow in the reverse direction.



JIS graphic symbols for hydraulic system



Nomenclature

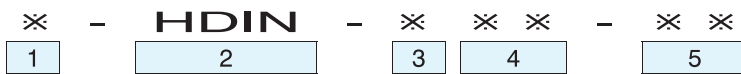

- 1 Applicable fluid code**
No designation: Petroleum-based hydraulic fluid, waterglycol hydraulic fluid
F: Phosphate ester hydraulic fluid
- 2 Model No.**
HDIN: H series inline check valve
- 3 Connections**
T: Screw connection type
F: Flange connection type

- 4 Nominal diameter**
03: 3/8
06: 3/4
10: 1 1/4
12: 1 1/2
16: 2
24: 3
- 5 Cracking pressure code**
See the cracking pressure table below.

Cracking pressure table

Cracking pressure code	0	01	015	02	05	10	12	15	20	25	30	35	45	56	60	90
	Cracking pressure MPa (kgf/cm ²)															
Model No.	0 {0}	0.01 {0.5}	0.015 {0.15}	0.02 {0.2}	0.05 {0.5}	0.1 {1}	0.12 {1.2}	0.15 {1.5}	0.2 {2}	0.25 {2.5}	0.3 {3}	0.35 {3.5}	0.45 {4.5}	0.56 {5.6}	0.6 {6}	0.9 {9}
HDIN-T03	√	—	—	√	√	√	—	√	√	—	—	√	√	√	√	√
HDIN-T06	√	—	√	√	√	√	—	√	√	—	—	√	√	√	√	√
HDIN-F06	√	—	√	√	√	√	—	√	√	—	—	√	√	√	√	√
HDIN-T10	√	—	—	√	√	√	√	√	√	√	√	√	√	—	√	—
HDIN-F10	√	—	—	√	√	√	√	√	√	√	√	√	√	—	√	—
HDIN-F12	√	—	—	—	√	√	—	√	√	—	—	√	√	—	—	—
HDIN-T16	√	—	—	√	√	√	—	√	√	√	—	√	√	—	√	—
HDIN-T24	√	√	—	—	√	√	—	—	√	—	—	√	√	—	—	—

Specifications

Model code	Nominal diameter	Maximum operating pressure MPa (kgf/cm ²)	Maximum flow rate ℓ /min	Mass kg
HDIN-T03-※※	3/8	21 {210}	30	0.3
HDIN-T06-※※	3/4		75	0.7
HDIN-F06-※※			3.2	
HDIN-T10-※※	1 1/4		190	2.7
HDIN-F10-※※			6.9	
HDIN-F12-※※	1 1/2		240	13
HDIN-T16-※※	2		370	16
HDIN-T24-※※	3		1060	43

Accessories (Flange mount type)

Flange (JIS B 2291 SSA), O-ring, mounting bolts

Handling

- Valves of cracking pressure type "0" (cracking pressure of 0 Mpa {0 kgf/cm²}) need to be installed with the inlet port facing downward.

JCA SERIES

[Right-angle Check Valve]

- Installed in a hydraulic line perpendicular to the line, the check valve opens when the pressure reaches the cracking pressure, allowing fluid to flow only in one direction and blocking the flow in the reverse direction.



JIS graphic symbols for hydraulic system



Nomenclature



- | | |
|--|--|
| <p>1 Applicable fluid code
No designation: Petroleum-based hydraulic fluid, water-glycol hydraulic fluid
F: Phosphate ester hydraulic fluid</p> <p>2 Model No.
JCA: J series right-angle check valve</p> <p>3 Connections
G: Gasket mount type
T: Screw connection type
F: Flange connection type</p> | <p>4 Nominal diameter:
03: 3/8
06: 3/4
10: 1 1/4
12: 1 1/2
16: 2
24: 3</p> <p>5 Cracking pressure code
04 : 0.04 MPa {0.4 kgf/cm²}
50 : 0.5 MPa {5 kgf/cm²}</p> <p>6 Design No. (The design No. is subject to change)</p> |
|--|--|

Specifications

Model code	Nominal diameter	Maximum operating pressure MPa {kgf/cm ² }	Maximum flow rate l/min	Mass kg
JCA-G03-※-20	3/8	25 {250}	60	1.7
JCA-T03-※-20				0.9
JCA-G06-※-20	3/4		200	2.9
JCA-T06-※-20				1.7
JCA-F06-※-20			3.7	
JCA-G10-※-20	1 1/4		400	5.5
JCA-T10-※-20				5.6
JCA-F10-※-20				7.6
JCA-F16-※-20	2		800	20
JCA-F24-※-20	3			1600

Handling

- Valves of cracking pressure type "0" (cracking pressure of 0 Mpa {0 kgf/cm²}) need to be installed with the inlet port facing downward. The gasket mount type valves need to be installed with the gasket mating face facing downward (horizontal orientation).

Cracking pressure table

Code	0	01	02	20	35
Model No.	Cracking pressure MPa {kgf/cm ² }				
	0 {0}	0.01 {0.1}	0.02 {0.2}	0.2 {2}	0.35 {3.5}
JCA-※03	√	√	√	√	√
JCA-※06	√	√	—	√	√
JCA-※10	√	—	—	√	√
JCA-F 16	√	—	—	√	√
JCA-F 24	√	—	—	√	√

Sub-plate model code

The sub-plate is not provided with the valve. Order it separately as required by specifying the model code given in the table below.

Model code	Nominal diameter	Connection port diameter	Mass kg
JCP-03M	3/8	Rc 3/8	1.6
JCP-03M04		Rc 1/2	
JCP-06M	3/4	Rc 3/4	2.4
JCP-06M08		Rc1	3
JCP-10M	1 1/4	Rc 1 1/4	4.8
JCP-10M12		Rc 1 1/2	5.7

Accessories

Connections	Model No.	Hexagon socket head cap bolt	Quantity	Tightening torque N-m {kgf-cm}
Gasket mount type	JCA-G03	M10 x 45	4	48 to 63 {480 to 630}
	JCA-G06	M10 x 50	4	48 to 63 {480 to 630}
	JCA-G10	M10 x 55	6	48 to 63 {480 to 630}
Flange connection type	Flange(JIS B 2291 SSA), O-ring, mounting bolts			

MT-02 SERIES

[02 Series Stacking Type Port A/B Throttle Valves]

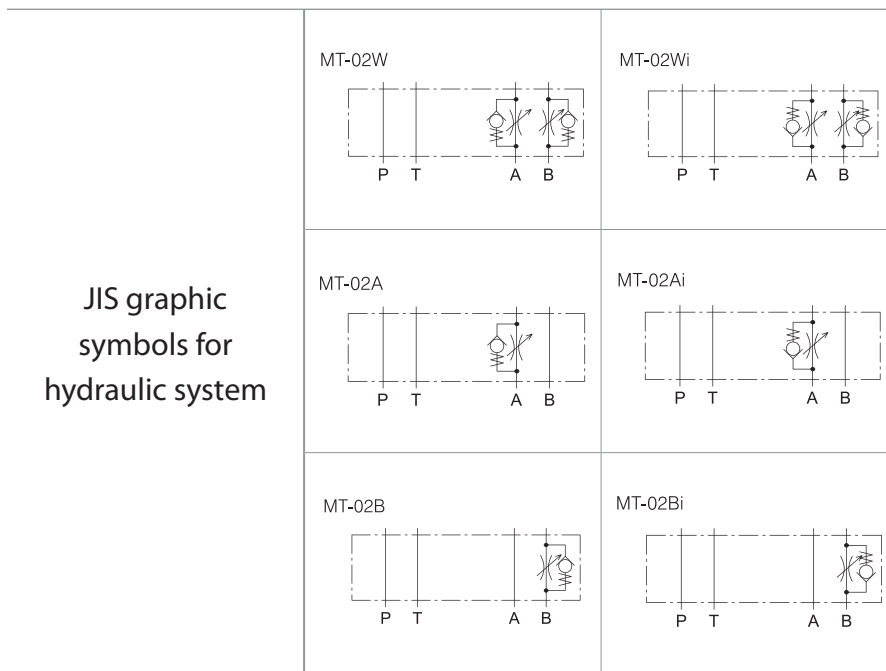

Nomenclature

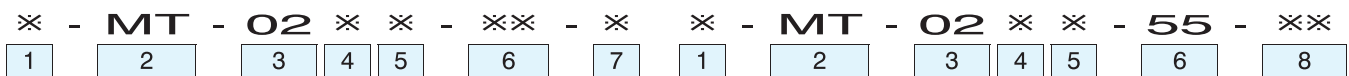

- 1 Applicable fluid code**
No designation: Petroleum-based hydraulic fluid,
water-glycol hydraulic fluid
F: Phosphate ester hydraulic fluid
- 2 Model No.**
MT: Modular stacking type throttle valve
- 3 Nominal diameter**
02: 1/4
- 4 Control port**
W: Port A/B
A: Port A
B: Port B
- 5 Control method**
No designation: Meter-out control
i: Meter-in control

- 6 Design No.**
55: 25 MPa {250 kgf/cm²} series
60: 35 MPa {350 kgf/cm²} series
- 7 Option code**
No designation: Flow rate adjusting screw type
T: Flow rate adjusting handle type
(applicable only to design No. 55)
- 8 Control No. < Low quantity range control type >**
32: Control flow rate 14 ℓ/min
(at differential pressure of 2 MPa {20 kgf/cm²})
33: Control flow rate 20 ℓ/min
(at differential pressure of 2 MPa {20 kgf/cm²})

Specifications

Model code	Maximum operating pressure MPa {kgf/cm ² }	Maximum flow rate ℓ/min	Mass kg
MT-02W※-55	25 {250}	40	1.3
MT-02A(B)※-55			1
MT-02W※-55-32			1.4
MT-02A(B)※-55-32			1.1
MT-02W※-55-33			1.4
MT-02A(B)※-55-33			1.1
MT-02W※-60	35 {350}		1.4
MT-02A(B)※-60			1.2

Handling

- The flow rate will not be zero even when the flow rate adjusting screw is fully tightened.

MP-02 SERIES [02 Series Stacking Type Pilot Operated Check Valves]

JIS graphic symbols for hydraulic system

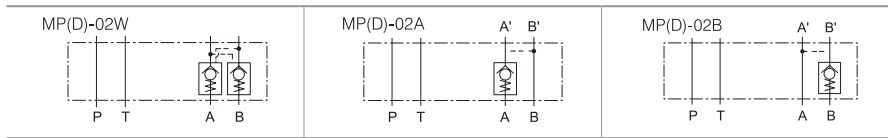

Nomenclature

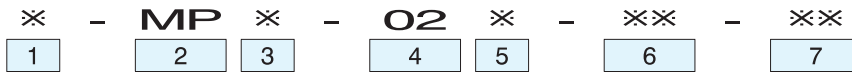

- 1 Applicable fluid code**
No designation: Petroleum-based hydraulic fluid, water-glycol hydraulic fluid
F: Phosphate ester hydraulic fluid
- 2 Model No.**
MP: Modular stacking type pilot operated check valve
- 3 Decompression code**
No designation: Direct operated type
D: Decompression type (applicable only to design No. 55)
- 4 Nominal diameter**
02: 1/4
- 5 Control port**
W: Port A/B
A: Port A
B: Port B
- 6 Cracking pressure code 20: 0.2 MPa {2 kgf/cm²}**
50: 0.5 MPa {5 kgf/cm²}
- 7 Design No.**
55: 25 MPa {250 kgf/cm²}
60: 35 MPa {350 kgf/cm²}

Specifications

Model code	Maximum operating pressure MPa {kgf/cm ² }	Maximum flow rate ℓ/min	Cracking pressure MPa {kgf/cm ² }	Area ratio	Mass kg
MP×-02×-20-55	25 {250}	40	0.2 {2}	(1) 2.7 : 1 (2) 1.96 : 1 (3) 16 : 1	1.1
MP×-02×-50-55			0.5 {5}		
MP-02×-20-60	35 {350}		0.2 {2}		1.2
MP-02×-50-60			0.5 {5}		

Handling

The internal drain type is adopted.

MPD-04 SERIES [04 Series Stacking Type Pilot Operated Check Valves]

JIS graphic symbols for hydraulic system

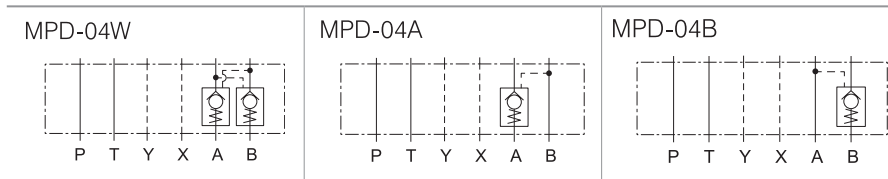

Nomenclature

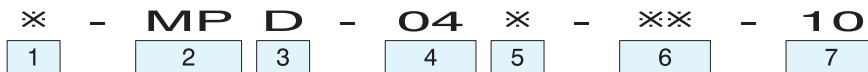

- 1 Applicable fluid code**
No designation: Petroleum-based hydraulic fluid, water-glycol hydraulic fluid
F: Phosphate ester hydraulic fluid
- 2 Model No.**
MP: Modular stacking type pilot operated check valve
- 3 Decompression code**
D: Decompression type
- 4 Nominal diameter**
04: 1/2
- 5 Control port**
W: Port A/B
A: Port A
B: Port B
- 6 Cracking pressure code**
20: 0.2 MPa {2 kgf/cm²}
50: 0.5 MPa {5 kgf/cm²}

Specifications

Model code	Maximum operating pressure MPa {kgf/cm ² }	Maximum flow rate ℓ/min	Cracking pressure MPa {kgf/cm ² }	Area ratio	Mass kg
MPD-04×-20-10	35 {350}	300	0.2 {2}	(1) 2 : 1 (2) 13.27 : 1	6.8
MPD-04×-50-10			0.5 {5}		



FILTRATION & HEAT EXCHANGER

SUCTION STRAINER : SFN SERIES	23
SUCTION STRAINER : SFT / SFG SERIES	24
SUCTION LINE FILTER : VN SERIES	25
SUCTION LINE FILTER : TSF SERIES	26
IN-LINE FILTER : UL SERIES	27
IN-LINE FILTER : UM SERIES	28
IN-LINE FILTER : UH SERIES	29
IN-LINE FILTER : AK SERIES	30
RETURN LINE FILTER : TRA / TRF SERIES	31
RETURN LINE FILTER : TR SERIES	32
CARTRIDGE FILTER : CF SERIES	33
BREATHER : AP SERIES	34
OFF-LINE FILTER : FP SERIES	35
OFF-LINE FILTER : FP SERIES "OIL REFRESHER"	37
SHELL AND TUBE TYPE : FCF SERIES	39
AIR-COOLED TYPE : ATK SERIES	40
AIR-COOLED TYPE : ATS SERIES	41

SUCTION STRAINER : SFN SERIES

Suction Strainer Standard Flow Rate : 7 ~ 530 ℓ/min.

- For General hydraulic fluid
- Less widening of filtration gap and stable performance comparing with wire gauze
- Flat surface of notch wire (dimple wire) enables easy cleaning
- Pipe connection type is "Rc threaded"

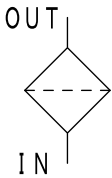

oil filter

Specification

Inner diameter		02	03	04	06	08	10	12	16	20	24
Standard flow rate *	ℓ/min	7	17	30	41	60	160	200	270	425	530
Max working pressure	MPa	-0.1 ~ 0									
Working temperature	°C	-10 ~ 150									
Main material	Inlet, Fin tube, End plate	Aluminum, SS									
	Filtration media (Notch wire)	Stainless-steel									
Coating		Non-coating									
Weight	kg	0.21	0.28	0.49	1.02	1.42	1.77	2.77	2.87		

* Standard flow rate is estimated by the condition of density : 0.86, kinematic viscosity : 32mm²/s, filtration rating: 150K, pressure drop : lower than 0.05MPa. (Since it is adjusted by characteristic of each product, value can be different in some cases.)

Model Code

(Model code example)

SFN — **08** — **150K**

Code	Inner diameter
02	Rc 1/4
03	Rc 3/8
04	Rc 1/2
06	Rc 3/4
08	Rc1
10	Rc1 1/4
12	Rc1 1/2
16	Rc2
20	Rc2 1/2
24	Rc3

Code	Filtration rating
Notch wire (Dimple wire)	
200K	200Mesh
150K	150Mesh
100K	100Mesh
60K	60Mesh

SUCTION STRAINER : SFT / SFG SERIES

Suction Filter Standard Flow Rate: 7 ~ 817 ℓ/min

- SFT : General hydraulic fluid, SFG : Fire-resistant hydraulic fluid
- All stainless-steel SFG is available for water-based fluid
- Pleated wire gauze enables large filtration area and space saving
- Cleanable and reusable because of stainless-steel wire gauze
- Pipe connection type is "Rc threaded"

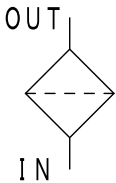

oil filter

FILTRATION & HEAT EXCHANGER

Specification

Inner diameter		02	03	04	06	08	10	12	16	20	24
Standard flow rate * ℓ/min		7	17	25	52	91	140	206	337	605	817
Max working pressure MPa		-0.1~0									
Working temperature °C		-10~150									
Main material	Inlet, Inner tube End plate	SFT	Plated steel plate, SS								
		SFG	Stainless-steel								
	Filtration media (Wire gauze)	Stainless-steel									
Coating		Non-coating									
Weight kg	SFT	0.085	0.115	0.2	0.325	0.405	0.59	0.75	0.95		
	SFG	0.075	0.105	0.19							

* Standard flow rate is estimated by the condition of density : 0.86, kinematic viscosity : 32mm²/s, filtration rating: 150W, pressure drop: lower than 0.05MPa. (Since it is adjusted by characteristic of each product, value can be different in some cases.)

Model Code

(Model code example)

SFT
SFG

08

150W

Code	Fluid type
SFT	Mineral oil
SFG	Fire resistant fluid
	Water

Code	Inner diameter
02	Rc 1/4
03	Rc 3/8
04	Rc 1/2
06	Rc 3/4
08	Rc1
10	Rc1 1/4
12	Rc1 1/2
16	Rc2
20	Rc2 1/2
24	Rc3

Code	Filtration rating
Wire gauze	
200W	200Mesh
150W	150Mesh
100W	100Mesh
60W	60Mesh

SUCTION LINE FILTER : VN SERIES

Suction Filter Case type, Standard Flow Rate: 20 ~ 1,350 ℓ/min

- Special structure to prevent air pocket inside filter
- Special structure to prevent flow-out of collected particles when replacing element
- Light filter housing of aluminum alloy
- Clogging indicator*1 and relief valve are included in standard model
- Magnet is installable for magnetic particle removal (option)
- Pipe connection type is "flange" for standard model (option : Rc threaded type companion flange)



FILTRATION & HEAT EXCHANGER

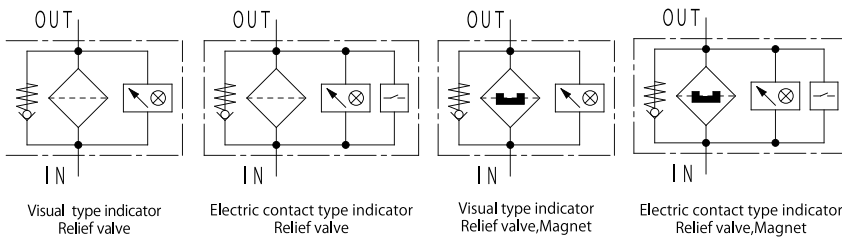

Specification

Max working pressure	MPa	0.5
Working temperature	Standard	°C -10 ~ 90
	High temperature*2	°C -10 ~ 130
Indicator working pressure	MPa	0.02
Cracking pressure	MPa	0.023
Allowable differential pressure of filter element	MPa	0.15
Flow direction / Extract direction of filter element		IN→OUT / Upward

Inner diameter		03A	04A	06A	08A	10A	12A	16A	20B	24B	28A	32A
Standard flow rate *	ℓ/min	20	36	70	120	240	330	490	670	830	1070	1350
Main material	Body	AC										
	Upper cover	ADC										AC
Coating		Non-coating										
Weight	kg	3.0		5.0		6.0		8.5		11.0		20.0

* Standard flow rate is estimated by the condition of density:0.86, kinematic viscosity : 32mm²/s, filtration rating: 150W, pressure drop: lower than 0.05MPa. (Since it is adjusted by characteristic of each product, value can be different in some cases.)
 Ⓢ Size: Inner diameter 125A and 150A are available (built-to-order)

Model Code

(Model code example)



Code	Fluid type
Blank	Mineral oil
F	Phosphate ester fluid
G	Water glycol fluid
C	Fatty ester fluid
W	High water base fluid
S	Fuel (Kerosene, Gas oil, Diesel oil)
B	Brake fluid

Code	Inner diameter
03A	10A
04A	15A
06A	20A
08A	25A
10A	32A
12A	40A
16A	50A
20B	65A
24B	80A
28A	90A
32A	100A

Code	Filtration rating
60W	60Mesh
100W	100Mesh
150W	150Mesh
200W	200Mesh

Code	Option
① Indicator	
Blank	Closing plug
I	Visual type (Standard)
E	Electric contact type
D	Electric contact type (Micro capacity)
② Magnet	
Blank	Non
M	Magnet
③ Companion flange	
Blank	Weld type (Standard)
P	Rc threaded type

* 1 Visual type indicator is installed for standard model. Electric contact type indicator is selectable as an option.
 * 2 Sealing parts: FKM, visual type indicator is available (Max oil temperature is electric contact type : 90°C)

SUCTION LINE FILTER : TSF SERIES

Suction Filter Case type, Standard Flow Rate: 40 ~180 ℓ/min

- Directly installable on tank-top (piping at Outlet side only)
- Light filter housing of aluminum alloy (steel housing for large models)
- Pressure gauge/switch for secondary pressure is available as an option
- Relief valve is available as an option
- Pipe connection type is "Rc threaded" and "flange" for standard model (option: companion flange)

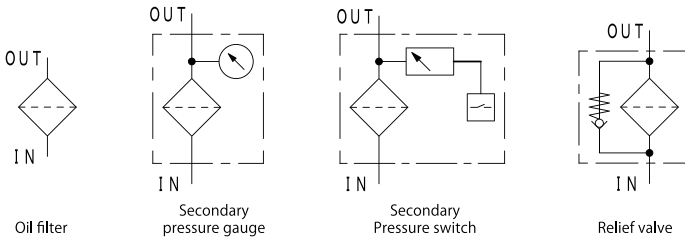

Specification

Max working pressure	MPa	0.5
Working temperature	Standard	°C -10 ~ 90
	High temperature*1	°C -10 ~150
Measurable pressure range	MPa	-0.1~0
Cracking pressure	MPa	0.04
Allowable differential pressure of filter element	MPa	0.15
Flow direction / Extract direction of filter element		IN→OUT / Upward

Inner diameter		06A	08A	10A	12A	16
Standard flow rate *	ℓ/min	40	50	95	130	180
Main material	Body	ADC				
	Case	Steel plate				
	Cover	ADC				
Coating	Body, Cover	Non-coating				
	Case	Protective film treatment				
Weight*2	kg	2.5		3.7		8.0

* Standard flow rate is estimated by the condition of density:0.86, kinematic viscosity : 32mm²/s, filtration rating : 150W, pressure drop: lower than 0.05MPa. (Since it is adjusted by characteristic of each product, value can be different in some cases.)

Model Code

(Model code example)

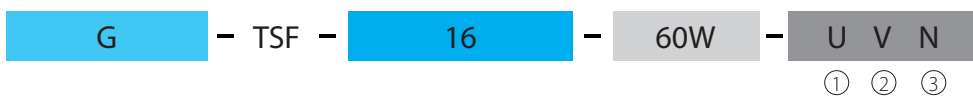

Code	Fluid type
Blank	Mineral oil
F	Phosphate ester fluid
G	Water glycol fluid
C	Fatty ester fluid
W	High water base fluid
S	Fuel (Kerosene, Gas oil, Diesel oil)
B	Brake fluid*3

Code	Inner diameter	
	IN	OUT
06A	Rc 3/4 (20A)	Rc1
08A	Rc1 (25A)	
10A	Rc1 1/4 (32A)	Rc1 1/2
12A	Rc1 1/2 (40A)	
16	Rc2 (50A)	Rc2

Code	Filtration rating
Wire gauze	
200W	200Mesh
150W	150Mesh
100W	100Mesh
60W	60Mesh

Code	Option	Indicator position	
① Indicator			
Blank	Closing plug	06A-12A	16
U	Pressure gauge (Secondary pressure)	On the upper cover	Opposite side of outlet
UR		Non	Right side as seen from outlet
UL		Non	Left side as seen from outlet
E	Electric contact type (Secondary pressure)	On the upper cover	Opposite side of outlet
ER		Non	Right side as seen from outlet
EL		Non	Left side as seen from outlet
D	Electric contact type (Micro capacity)	On the upper cover	Opposite side of outlet
DR		Non	Right side as seen from outlet
DL		Non	Left side as seen from outlet

② Relief valve	
K	Non
V	Relief valve

③ Companion flange	
Blank	Non
N	Companion flange

* 1 Sealing parts: FKM, indicator is not available (Max oil temperature is pressure gauge or electric contact type : 90°C)

* 2 Weight without companion flange

* 3 Electric contact type indicator is not available.

IN-LINE FILTER : UL SERIES

Line Filter 3.5MPa, Standard Flow Rate: 30 ~ 730 ℓ/min

- Light filter housing of aluminum alloy (FCD for large models)
- Exchange of In/Outlet is available by changing of cover direction
- Easy element replacement by only removing 4 bolts
- Clogging indicator, magnet, relief valve, and companion flange are selectable as an option
- Element of "U" series (UL, UM, UH) can be used in common



FILTRATION & HEAT EXCHANGER

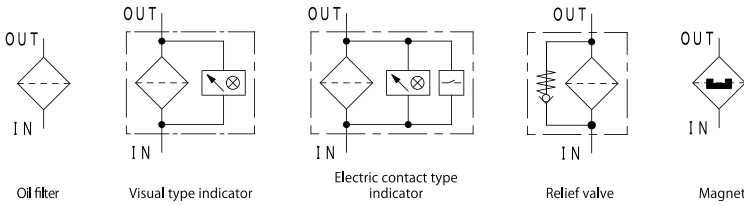

Specification

Max working pressure	MPa	3.5
Repetition durability test		0~3.5MPa x10 ⁷ times
Working temperature	Standard	°C -10~90
	High temperature* ¹	°C -10~150
Indicator working pressure	MPa	0.3
Cracking pressure	MPa	0.35
Allowable differential pressure of filter element	MPa	0.7
Flow direction/Extract direction of filter element		OUT→IN / Upward

Inner diameter		03A	04A	06A	08A	10A	12A	16A	20B	24B	
Standard flow rate *	ℓ/min	30	50	90	105	240	290	440	680	730	
Main material	Body	ADC						FCD			
	Cover	ADC						FCD			
	Inlet	ADC									
Coating		Non-coating						Aqua blue			
Weight** ²	kg	2.5		3.0		5.5		21.5		37.0	

* Standard flow rate is estimated by the condition of density : 0.86, kinematic viscosity : 32mm²/s, filtration rating: 10U, pressure drop: lower than 0.05MPa. (Since it is adjusted by characteristic of each product, value can be different in some cases.)

Model Code

(Model code example)



Code	Fluid type
Blank	Mineral oil
F	Phosphate ester fluid
G	Water glycol fluid
C	Fatty ester fluid
W	High water base fluid
S	Fuel (Kerosene, Gas oil, Diesel oil)
B	Brake fluid

Code	Inner diameter
03A	Rc 3/8 (10A)
04A	Rc 1/2 (15A)
06A	Rc 3/4 (20A)
08A	Rc1 (25A)
10A	Rc1 1/4 (32A)
12A	Rc1 1/2 (40A)
16A	Rc2 (50A)
20B	Rc2 1/2 (65A)
24B	Rc3 (80A)

Code	Filtration rating	Code	Filtration rating
C-Fiber		Wire gauze	
3C	3 μm	5UW	5 μm
8C	8 μm	10UW	10 μm
25C	25 μm	20UW	20 μm
Paper		40UW	
10U	10 μm	50UW	50 μm
20U* ³	20 μm	200W	200Mesh
40U* ³	40 μm	150W	150Mesh
		100W	100Mesh
		60W	60Mesh
Notch wire (Dimple wire)			
50UK	50 μm		
200K	200Mesh		
150K	150Mesh		
100K	100Mesh		
60K	60Mesh		

Code	Option
① Indicator	
Blank	Closing plug
I	Visual type
E	Electric contact type
D	Electric contact type (Micro capacity)
② Relief valve	
K	Non
V	Relief valve
③ Companion flange	
Blank	Non
N	Companion flange
④ Magnet	
Blank	Non
M	Magnet

Code	Flow direction of fluid
Blank	Left→Right
L	Right→Left

* 1 Sealing parts: FKM, only for wire gauze element, indicator and relief valve are not available (Max oil temperature is visual type: 130°C, electric contact type: 90°C)
 * 2 Weight without companion flange
 * 3 Not available for water-glycol based oil and high water based fluid

TAISEI KOGYO

IN-LINE FILTER : UM SERIES

Line Filter 7.0MPa, Standard Flow Rate: 30 ~ 730 ℓ/min

- Strong filter housing by FCD material.
- Exchange of In / Outlet is available by changing of cover direction
- Easy element replacement by only removing 4 bolts
- Clogging indicator, magnet, relief valve, and companion flange are selectable as an option
- Element of "U" series (UL, UM, UH) can be used in common

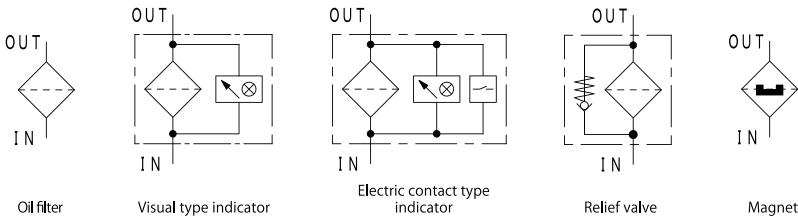

FILTRATION & HEAT EXCHANGER

Specification

Max working pressure	MPa	7.0								
Repetition durability test		0~7.0MPa x 10 ⁷ times								
Working Temperature	Standard	°C	-10 ~ 90							
	High temperature* ¹	°C	-10 ~ 150							
Indicator working pressure	MPa	0.3								
Cracking pressure	MPa	0.35								
Allowable differential pressure of filter element	MPa	0.7								
Flow direction / Extract direction of filter element		OUT → IN / Upward								

Inner diameter		03	04	06	08	10	12	16A	20B	24B
Standard flow rate *	ℓ/min	30	50	90	105	240	290	440	680	730
Main material	Body	FCD								
	Cover	FCD								
	Inlet	ADC								
Coating		Aqua blue								
Weight*²	kg	8.9		11.1		22.7		21.5		37.0

* Standard flow rate is estimated by the condition of density: 0.86, kinematic viscosity: 32mm²/s, filtration rating: 10U, pressure drop: lower than 0.05MPa.
(Since it is adjusted by characteristic of each product, value can be different in some cases.)

TAISEI KOGYO

Model Code

(Model code example)

F - UM - 08 - 10U - I V N M - L

①
②
③
④

Code	Fluid type	Code	Inner diameter	Code	Filtration rating	Code	Filtration rating	Code	Option	Code	Flow direction of fluid
Blank	Mineral oil	03	Rc 3/8 (10A)	C-Fiber		5UW	5 μm	Blank	① Indicator	Blank	Left→Right
F	Phosphate ester fluid	04	Rc 1/2 (15A)	Wire gauze		10UW	10 μm	I	Closing plug	L	Right→Left
G	Water glycol fluid	06	Rc 3/4 (20A)	3C	3 μm	20UW	20 μm	E	Visual type		
C	Fatty ester fluid	08	Rc1 (25A)	8C	8 μm	40UW	40 μm		Electric contact type		
W	High water base Fluid	10	Rc1 1/4 (32A)	25C	25 μm	50UW	50 μm	E	Electric contact type (Micro capacity)		
S	Fuel (Kerosene, Gas oil, Diesel oil)	12	Rc1 1/2 (40A)	Paper		200W	200Mesh	D	Relief valve		
B	Brake fluid	16A	Rc2 (50A)	10U	10 μm	150W	150Mesh		② Relief valve		
		20B	Rc2 1/2 (65A)	20U* ³	20 μm	100W	100Mesh	K	Non		
		24B	Rc3 (80A)	40U* ³	40 μm	60W	60Mesh	V	Relief valve		
						Notch wire (Dimple wire)			③ Companion flange		
						50UK	5 μm	Blank	Non		
						200K	200Mesh	N	Companion flange		
						150K	150Mesh		④ Magnet		
						100K	100Mesh	Blank	Non		
						60K	60Mesh	M	Magnet		

* 1 Sealing parts: FKM, only for wire gauze element, indicator and relief valve are not available (Max oil temperature is visual type: 130°C, electric contact type: 90°C)
 * 2 Weight without companion flange
 * 3 Not available for water-glycol based oil and high water based fluid

IN-LINE FILTER : UH SERIES

Line Filter 21.0 MPa, Standard Flow Rate : 30 ~ 480 ℓ /min

- High pressure element of allowable differential pressure 21MPa is available (standard : 0.7MPa)
- Exchange of In / Outlet is available by changing of cover direction
- Easy element replacement by only removing 4 bolts
- Clogging indicator, magnet, relief valve, and companion flange are selectable as an option
- Element of "U" series (UL, UM, UH) can be used in common



FILTRATION & HEAT EXCHANGER

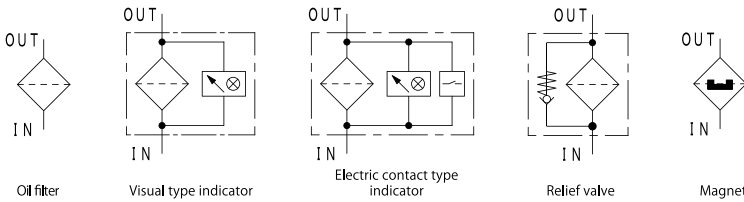

Specification

Max working pressure	MPa	21.0
Repetition durability test		0~21.0MPa x10 ⁷ times
Working Temperature	Standard	°C -10 ~ 90
	High temperature* ¹	°C -10 ~ 150
Indicator working pressure	Standard	MPa 0.3
	High pressure	MPa 0.7
Cracking pressure	Standard	MPa 0.35
	High pressure	MPa Non bypass
Allowable differential pressure of filter element	Standard	MPa 0.7
	High pressure	MPa 21.0
Flow direction/Extract direction of filter element		OUT → IN / Upward

Inner diameter		03A	04A	06A	08A	10A	12A	16A
Standard flow rate *	ℓ /min	35	60	110	125	280	380	480
Main material	Body	FCD						
	Cover	FCD						
	Inlet	ADC						
Coating		Aqua blue						
Weight*²	kg	10.0		12.2		25.4		36.6

* Standard flow rate is estimated by the condition of density: 0.86, kinematic viscosity: 32mm²/s, filtration rating: 10U, pressure drop: lower than 0.05MPa. (Since it is adjusted by characteristic of each product, value can be different in some cases.)

Model Code

(Model code example)



Code	Fluid type
Blank	Mineral oil
F	Phosphate ester fluid
G	Water glycol fluid
C	Fatty ester fluid
W	High water base Fluid
S	Fuel (Kerosene, Gas oil, Diesel oil)
B	Brake fluid

Code	Inner diameter
03A	Rc 3/8 (10A)
04A	Rc 1/2 (15A)
06A	Rc 3/4 (20A)
08A	Rc1 (25A)
10A	Rc1 1/4 (32A)
12A	Rc1 1/2 (40A)
16A	Rc2 (50A)

Code	Filtration rating	Code	Filtration rating
C-Fiber			
3C	3 μm	5UW	5 μm
8C	8 μm	10UW	10 μm
25C	25 μm	20UW	20 μm
High pressure C-Fiber			
3CH	3 μm	40UW	40 μm
8CH	8 μm	50UW	50 μm
25CH	25 μm	200W	200Mesh
Paper			
10U	10 μm	150W	150Mesh
20U* ³	20 μm	100W	100Mesh
40U* ³	40 μm	60W	60Mesh
Notch wire (Dimple wire)			
50UK	5 μm		
200K	200Mesh		
150K	150Mesh		
100K	100Mesh		
60K	60Mesh		



Code	Option
Blank	① Indicator
I	Closing plug
V	Visual type
E	Electric contact type
D	Electric contact type (Micro capacity)
Blank	② Relief valve* ⁴
K	Non
V	Relief valve
Blank	③ Companion flange
N	Companion flange
Blank	④ Magnet
M	Magnet

Code	Flow direction of fluid
Blank	Left → Right
L	Right → Left

* 1 Sealing parts: FKM, only for wire gauze element, indicator and relief valve are not available (Max oil temperature is visual type: 130°C, electric contact type: 90°C)
 * 2 Weight without companion flange
 * 3 Not available for water-glycol based oil and high water based fluid
 * 4 Relief valve is not available if selecting high pressure element

TAISEI KOGYO

IN-LINE FILTER : AK SERIES

- Maximum operating pressure : 1 MPa
- Element can be cleaned with scraper by rotating a handle.
Model AK : Notch wire element
- Thread type connection is provided as standard. Companion flange for flange connection is available in additional option.
- Please contact us for use of fluid other than mineral oil on packing, O-rings and other parts.



FILTRATION & HEAT EXCHANGER

O-ring and Packing

Part No.	12	15	16	17	20
Model					
AK-04	t2 X Ø14 / Ø6.5	Seal washer	G-60		
AK-06					
AK-08	t2 X Ø17 / Ø8.5			P-7	G-50
AK-10					
AK-12					
AK-16					G-70

Companion Flange Dimensions

Symbol	Companion Flange (option)						
	d _s	S	T	P	20	21	Mass kg
Model							
AK-04.06	Companion Flange is not attached						
AK08	34.5	8	12	50	G-50	M8 X 30	0.4
AK-10	43.2		14				
AK12	49.1	10	18	64	G-70	M10 X 40	0.8
AK16	61.1						

Dimensions and Standard Flow Rates

Symbol	d	H	H ₁	H ₂	A	C	D	a	Tap d ₂ X ℓ	Element Allowance E	Element		Mass (kg)	Standard Flow Rate (ℓ/min)
											h ₁	d ₁		
AK-04	Rc 1/2	202	56	146	84	72	59			235	90	44	0.8	20
AK-05	Rc 3/4													38
AK-08	Rc 1/2	300	75	225	120	102	79	22	M8 X 15	384	150	64	2.0	65
AK-10	Rc 1 1/4													130
AK-12	Rc 1 1/2	341	85	256	160	140	110	25	M10 X 20	427	166	84	4.7	200
AK16	Rc2													300

Model Code

(Model code example)



Code	Fluid
Blank	Mineral oil
Fluid Type	Phosphate ester-bases oil
G	Water glycol-bases oil

Code	Inner Dia.
04	15A (1/2B)
06	20A (3/4B)
08	25A (1B)
10	32A (1 1/4B)
12	40A (1 1/2B)
16	50A (2B)

Code	Filtration	Media
50UK	50 microns	Notch wire Model AK
200K	200 mesh	
150K	150 mesh	
100K	100 mesh	
60K	60 mesh	

*Code	Companion Flange
Blank	None
N	With

* Model "04" and "06" have no companion flange

Quick delivery of filters in [] with mineral oil use.

RETURN LINE FILTER : TRA / TRF SERIES

Return Filter 1.0MPa, Standard Flow Rate: 130 ~ 400 ℓ/min

- Lower pressure drop and higher flow rate model by CFD (computational fluid dynamics)
- The new "High flow" element is available
- Differential pressure type indicator (TRA) and Primary pressure gauge (TRF) are selectable as an option
- Direct installation on tank-top is available (pipe connection is at inlet only)



FILTRATION & HEAT EXCHANGER

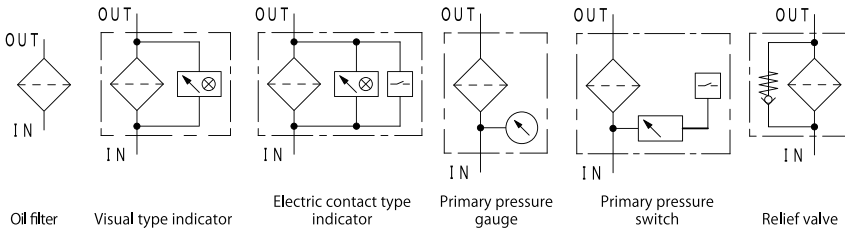

Specification

Max working pressure	MPa	1.0
Repetition durability test		0~1.0MPa x 10 ⁷ times
Working Temperature	Standard	°C -10 ~ 90
	High temperature*1	°C -10 ~ 150
Indicator working pressure	MPa	0.3
Cracking pressure	MPa	0.35
Allowable differential pressure of filter element	MPa	0.7
Flow direction/Extract direction of filter element		OUT → IN / Upward

Model code		TRA				TRF			
Inner diameter		06	08	10	12	06A	08A	10A	12A
Standard flow rate*	Standard ℓ/min	130	170	320	340	130	170	320	340
	High flow ℓ/min	145	185	360	400	145	185	360	400
Main material	Body	ADC							
	Cover	ADC							
Coating	Body	Non-coating							
	Cover	Non-coating							
Weight*2	kg	2.7		4.1		2.5		3.7	

* Standard flow rate is estimated by the condition of density: 0.86, kinematic viscosity: 32mm²/s, filtration rating: 10U/10UF, pressure drop: lower than 0.05MPa. (Since it is adjusted by characteristic of each product, value can be different in some cases.)

Model Code

(Model code example)



Code	Fluid type
Blank	Mineral oil
F	Phosphate ester fluid
G	Water glycol fluid
C	Fatty ester fluid
W	High water base Fluid
S	Fuel (Kerosene, Gas oil, Diesel oil)
B	Brake fluid

Code	Inner diameter	
	IN	OUT
06	Rc 3/4 (20A)	Rc1
08	Rc1 (25A)	Rc1
10	Rc1 1/4 (32A)	Rc1 1/2
12	Rc1 1/2 (40A)	Rc1 1/2
06A	Rc 3/4 (20A)	Rc1
08A	Rc1 (25A)	Rc1
10A	Rc1 1/4 (32A)	Rc1 1/2
12A	Rc1 1/2 (40A)	Rc1 1/2

Code	Filtration rating	Code	Filtration rating
C-Fiber			
3C	3 μm	5UW	5 μm
8C	8 μm	10UW	10 μm
25C	25 μm	20UW	20 μm
Paper			
10U	10 μm	50UW	50 μm
20U*3	20 μm	200W	200Mesh
40U*3	40 μm	150W	150Mesh
High Flow Paper			
10UF*3	10 μm	100W	100Mesh
20UF*3	20 μm	60W	60Mesh

TRA		TRA	
Code	① Indicator	Code	① Pressure gauge
Blank	Closing plug	Blank	Closing plug
I	Visual type	I	Pressure gauge
E	Electric contact type	E	Pressure switch
D	Electric contact type (Micro capacity)		
Common to all models			
Code	② Relief valve		
K	Non		
V	Relief valve		
Code	③ Companion flange		
Blank	Non		
N	Companion flange		

* 1 Sealing parts: FKM, only for wire gauze element, indicator and relief valve are not available (Max oil temperature is visual type: 130°C, electric contact type/pressure gauge/pressure switch: 90°C)
 * 2 Weight without companion flange
 * 3 Not available for water-glycol based oil and high water based fluid

TAISEI KOGYO

RETURN LINE FILTER : TR SERIES

Return Filter 1.0MPa, Standard Flow Rate : 30 ~ 40 ℓ/min

- Double role with built-in air breather (60 mesh)
- Light filter housing of aluminum alloy, ADC
- Relief valve is included in standard model
- Pressure gauge for clogging check is selectable as an option
- Pipe connection type is "Rc threaded"

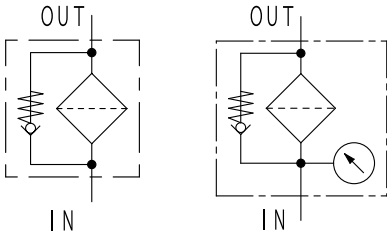

Relief valve

Primary pressure gauge
Relief valve

Specification

Max working pressure	MPa	1.0
Working temperature	Standard	°C - 10 ~ 90
	High temperature*1	°C - 10 ~ 150
Measurable pressure range	MPa	0 ~ 1.0
Cracking pressure	MPa	0.25
Allowable differential pressure of filter element	MPa	0.7
Flow direction/Extract direction of filter element		OUT → IN / Upward

Inner diameter		03	04
Standard flow rate *	ℓ /min	30	40
Main material	Body	ADC	
	Cover	ADC	
Coating		Non-coating	
Weight	kg	0.75	

* Standard flow rate is estimated by the condition of density : 0.86, kinematic viscosity : 32mm²/s, filtration rating: 10U, pressure drop: lower than 0.05 MPa. (Since it is adjusted by characteristic of each product, value can be different in some cases.)

Model Code

(Model code example)



Code	Fluid type
Blank	Mineral oil
F	Phosphate ester fluid
G	Water glycol fluid
C	Fatty ester fluid
W	High water base fluid
S	Fuel (Kerosene, Gas oil, Diesel oil)
B	Brake fluid

Code	Inner diameter
03	Rc 3/8
04	Rc 1/2

Code	Filtration rating	Code	Filtration rating
C-Fiber			
3C	3 μm	5UW	5 μm
8C	8 μm	10UW	10 μm
25C	25 μm	20UW	20 μm
Paper			
10U	10 μm	40UW	40 μm
20U*2	20 μm	50UW	50 μm
40U*2	40 μm	200W	200Mesh
		150W	150Mesh
		100W	100Mesh
		60W	60Mesh
		40W	40Mesh

Code	Option
Blank	Non
P	Pressure gauge

* 1 Sealing parts: FKM, only for wire gauze element, pressure gauge and relief valve are not available (Max oil temperature is pressure gauge : 90°C)

* 2 Not available for water-glycol based oil and high water based fluid

CARTRIDGE FILTER : CF SERIES

Cartridge Filter 0.5MPa, Standard Flow Rate: 25 ~ 85 ℓ/min

- Easy maintenance by cartridge replacement
- Applicable to both total amount filtration and partial filtration depending on flow rate
- Built-in relief valve prevents cartridge from breakdown by clogging
- Pressure gauge is installable at 4 positions: In/Outlet, left/right side (option)
- Pipe connection type is "Rc threaded"

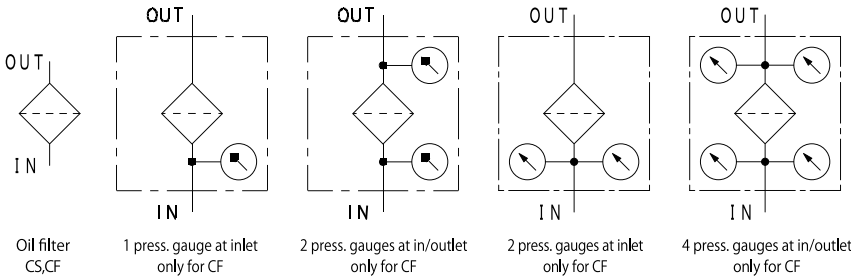

FILTRATION & HEAT EXCHANGER

Specification

Max working pressure	MPa	0.5
Working temperature	°C	-10 ~ 90
Working fluid		Mineral oil
Measurable pressure range	MPa	0 ~ 1.0
Cracking pressure	MPa	0.1
Flow direction/Extract direction of filter element		OUT → IN / Downward

Model code		CS-04	CF-06	CF-08
Standard flow rate ※	ℓ /min	25	70	85
Main material	Body	Aluminum		
Coating	Body	Non-coating		
	Cartridge	Blue gray	Gray	
Weight	kg	0.49	0.92	

※ Standard flow rate is estimated by the condition of density: 0.86, kinematic viscosity: 32mm²/s, filtration rating: 10U, pressure drop: lower than 0.05MPa.
(Since it is adjusted by characteristic of each product, value can be different in some cases.)

Model Code

(Model code example)



Code	Inner diameter
Cs	04 Rc 1/2
CF	06 Rc 3/4
	08 Rc 1

Code	Filtration rating
	Paper
10U	10 μm

Code	Option
Only for CF	
①	Pressure gauge
Blank	Non
P1	1 pc
P2	2 pcs
P3	3 pcs
P4	4 pcs

TAISEI KOGYO

BREATHER : AP SERIES

Air Breather Standard Flow Rate : 0.06 ~ 15.0 m³ /min

- Appropriate to avoid contamination from air inlet of a tank
- Standard filter element is hard paper (equivalent to 20µm)
- Each filtration rating of C-fiber, paper, and wire gauze is selectable for filter element (Not available for AP-02)
- Pipe connection type: AP-02~24 "R Thread", AP-32, 48 "flange (JIS 5K SOP, FF)"

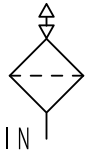

Air breather

FILTRATION & HEAT EXCHANGER

Specification

Inner diameter	02	03	04	06	08	12	16	24	32	48	
Air flow rate * m ³ /min	0.06	0.10	0.15	0.20	0.40	0.90	2.00	4.00	7.00	15.0	
Working temperature °C	- 10 ~ 90										
Main material	Cover	Steel plate						Plated steel plate	Steel plate		
	Nipple	ADC									
	Body								SGP, Steel plate, SS		
Coating	Dark yellow (Upper cover)								Aqua blue		
Weight kg	0.04	0.09	0.14	0.15	0.20	0.35	0.65	1.30	7.50	14.5	

* Please ask us for compatibility of fluid other than mineral oil.

⊕ Standard flow rate is estimated by the condition of air temperature: 20°C, filtration rating (AP-02 ~ 24: hard paper (equivalent to 20 µm), AP-32,48:paper (20 µm)),and ventilation resistance: lower than 0.5kPa.

Model Code

(Model code example)



Code	Inner diameter
02	R 1/4
03	R 3/8
04	R 1/2
06	R 3/4
08	R1
12	R1 1/2
16	R2
24	R3
32	JISSK-100A
48	JISSK-150A

Code	Option
Blank	Non (standard)
W*2	Outdoor spec.*3

Code	Filtration rating	Code	Filtration rating
Hard paper		Wire gauze	
Blank	20 µm Equivalent	5UW	5 µ m
C-Fiber		10UW	10 µ m
3C	3 µ m	20UW	20 µ m
8C	8 µ m	40UW	40 µ m
25C	25 µ m	50UW	50 µ m
Paper		200W	200Mesh
10U	10 µ m	150W	150Mesh
20U*1	20 µ m	100W	100Mesh
40U	40 µ m	60W	60Mesh

* 1 20µm paper (20U) is a standard element for AP-32 and AP-48.

* 2 Not available for AP-32 and AP-48.

* 3 Since it is a simple drip-proof structure to avoid water inlet such as rain drops from above, it cannot shut water inlet from below. Please note that upper cover should be at top when installation.

OFF-LINE FILTER : FP SERIES

[Filtration Unit with Pump motor]

Basic Model Off-line Filter for oil cleanliness improvement

FP-400 series

- Handy type filtration unit is appropriate to new oil filtration
- Easy maintenance by spin-on cartridge replacement

FP-750/1500 series

- Cart type filtration unit enables movable filtration at several locations
- High performance C-fiber element and other filtration rating are selectable

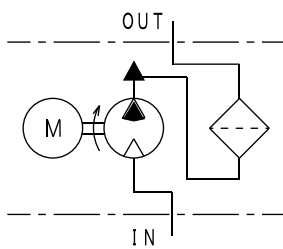

FP-400,750

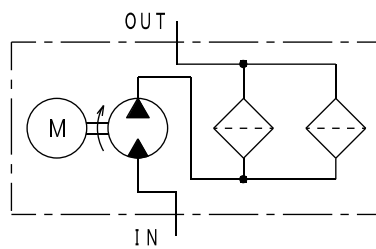

FP-1500S-5060

Specification

Corresponding fluid	Oil type	Mineral oil
	Kinematic viscosity	mm ² /s Under 300 (standard)
Max working pressure	°C	80
Cracking pressure	MPa	0.3

Specification / Model code			400Y-2512	400Y-1318	750S-4030	1500S-5060A
Pump	Flow rate	50Hz	12		30	58.5
		60Hz	14.4		36	70.2
	Discharge pressure	50Hz	0.4		0.55	0.8
		60Hz		0.35	0.6	
IN-OUT inner diameter			Rc 1/2		Rc 3/4	Rc 1 1/4
Motor	Voltage	V	Single phase 100/200		3 phase 200	
	output	kW	0.4		0.75	1.5
Accessory	Suction strainer		Model : SFW-04S (Option)		Y-type suction strainer	
	Braid hose		IN: Ø22x2.0m/ OUT : Ø18x2.0m		IN/OUT : Ø19x2.0m	IN/OUT : Ø32x2.0m
Weight	kg	15	18	60	122	

Model Code

(Model code example)

FP - 400Y - 1348 - 3C - 1

Code	Type
400Y	Handy
750S	Cart
1500S	Cart

Code	Element size
2512	Ø 95 x L135
1318	Ø 130 x L180
4030	Ø 152 x L426 (Single type)
5060A	Ø 152 x L426 (Duplex type)

Code	Filtration rating
C-Fiber	
3C	3 µm
8C ⁺	8 µm
Peper	
10U	10 µm

Voltage		
Only for FP-400Y		
1	100V	Standard
2	200V	Special*
FP-750S/1500S		
Blank	200V	Standard**

* Please ask us for 200V since price and delivery are different with standard.

** Please ask us for special specification : overseas spec (different AC voltage).

* 1 8C (8 µm) is only for FP-750S and FP-1500S.

Dimension - Parts List

FP-400Y-2512-□□

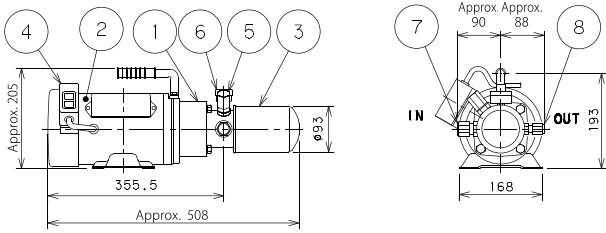

Spare cartridge model
L-9B-□□

No.	Item	Qty
1	Pump	1
2	Motor	1
3	Cartridge filter	1
4	Push switch	1
5	Relief valve	1
6	Pressure gauge Model : ut-3	1
7	In-side hose nipple	1
8	Out-side hose nipple	1

FP-400Y-1318-□□

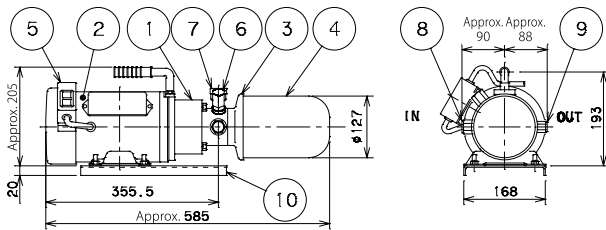

Spare cartridge model
N-1318-□□

No.	Item	Qty
1	Pump	1
2	Motor	1
3	Cartridge adapter	1
4	Cartridge filter	1
5	Push switch	1
6	Relief valve	1
7	Pressure gauge Model : ut-3	1
8	In-side hose nipple	1
9	Out-side hose nipple	1
10	Base	1

FP-750S-4030-□□

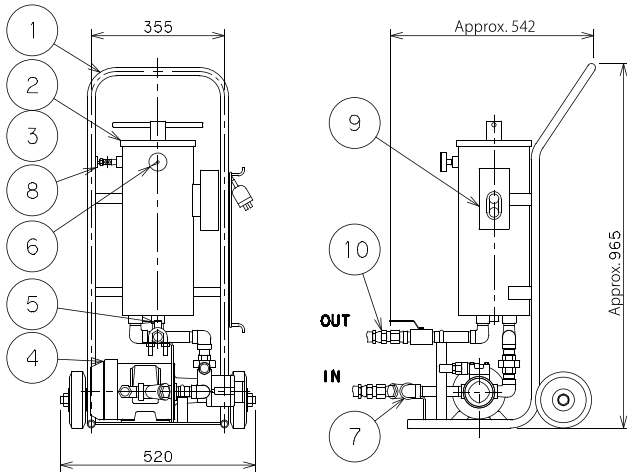

Spare element model
P-LCN-6-□□

Sealing Part

⊕ Parts quantity is for 1 filter case.

	Filter case Cover part packing	Filter element Upper O-ring	Filter element Lower O-ring
Size	t3x Ø194/ Ø178	JIS B2401,1A P20	AS568-243
Qty	1	1	2

FP-1500S-5060-□□

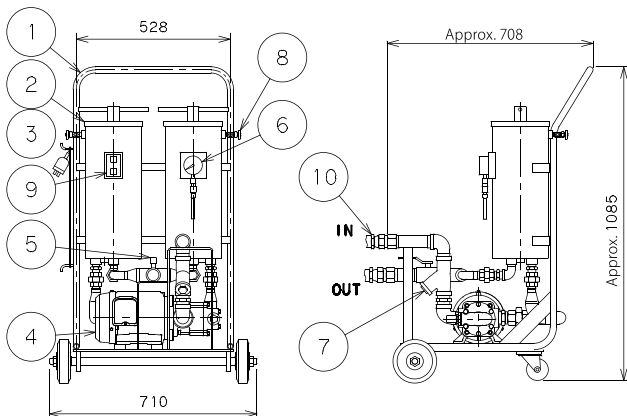

Spare element model
P-LCN-6-□□

Sealing Part

⊕ Parts quantity is for 1 filter case.

	Filter case Cover part packing	Filter element Upper O-ring	Filter element Lower O-ring
Size	t3x Ø194/ Ø178	JIS B2401,1A P20	AS568-243
Qty	1	1	2

OFF-LINE FILTER : FP SERIES

["Oil Refresher" Filtration Unit with Pump motor & Centrifugal Separator]

High performance Off-line Filter for oil cleanliness improvement

- "Oil Refresher" enables TAISEI's original triple filtration method :
 - ① Sludge removal by Centrifugal separator
 - ② Water elimination by Water absorption element
 - ③ Fine particle removal by High performance C-fiber element
- Lower running cost comparing with a general off-line filter
- Clogging indicator (electric contact type) is included in standard model
- Integration time meter, outside lamp, and sight glass are selectable for special accessory
- Cart-type filtration unit enables movable filtration at several locations

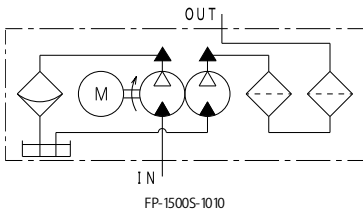

FILTRATION & HEAT EXCHANGER

TAISEI KOGYO

Corresponding fluid	Oil type	Mineral
	Kinematic viscosity	mm ² /s 20~200
	(Standard temperature)	°C [ISO VG32 : 7 ~ 52 VG46 : 13 ~ 60 VG68 : 21 ~ 61]
Max working pressure	°C	0~60
Cracking pressure	MPa	0.3

Pump	Flow rate	ℓ/min	50Hz 9 60Hz 10.8	
	Discharge pressure	MPa	1.0	
	Cracking pressure	MPa	IN→Centrifugal separator	0.7
			Tank→Filter	0.7
IN-OUT inner diameter			Rc1/2	
Motor	Voltage	V	3 phase 200*	
	Output	kW	1.5	
Accessory	Suction strainer	Y-type suction strainer (Standard equipment)		
	Braid hose	IN/OUT : 1/2 B x 2.0m		
Weight	kg	About 95		

* Please ask us for special specification : overseas spec (different AC voltage).

Model Code

(Model code example)

FP - 1500S - 1010 - 3C - S H T

① ② ③

Code	Filtration rating
C-Fiber	
3C	3μm
8C	8μm

Code	Option
① Sight glass	
Blank	Non
S	Sight glass
② IN,OUT,hose tip shape	
Blank	Joint (R 1/2)
H	Non (Notch)
③ Control box	
Blank	Non
T	Integration time meter
R	Outside lamp
TR	Integration time meter, Outside lamp

Flow Rate Graph

Condition

Fluid type : ISO VG46 Tank capacity : 40 ℓ Dust type : ACFTD Amount of water : 100cc

FP model Cleanliness

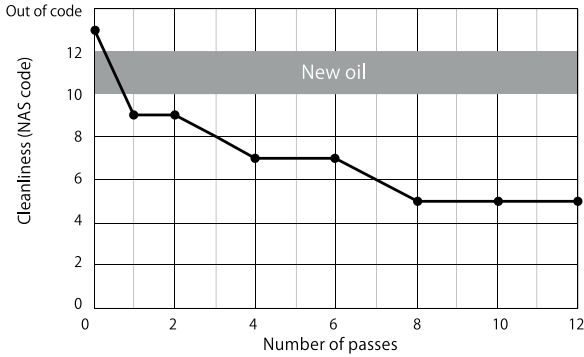

FP model Amount of water removal

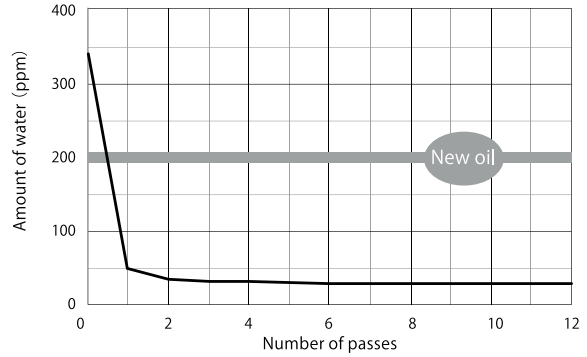

Dimension • Parts List

FP-1500S-1010-□□-S□□

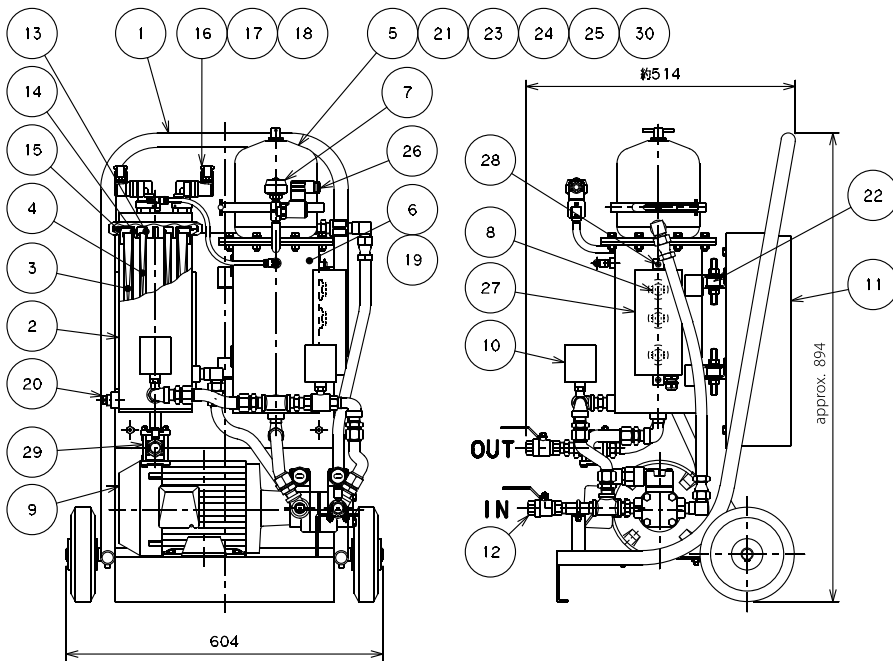

No.	Item	Qty
1	Carrier	1
2	Filter	1
3	Water absorption element	1
4	Filter element	1
5	Centrifuge	1
6	Tank	1
7	Air breather Model : AP-02	1
8	Level sensor	3
9	Pump motor	1
10	Ball valve	2
11	Control box	1
12	Ball valve	2
13	O-ring	2
14	O-ring	2
15	O-ring	1
16	Indicator Mode : EA-3	2
17	O-ring	2
18	O-ring	2
19	Packing	1
20	Drain plug	2
21	Packing	1
22	Rubber vibration isolator	4
23	Paper insert	1
24	O-ring	1
25	O-ring	1
26	Solenoid valve	1
27	Sensor Cover	1
28	Screw	2
29	Sight glass	1
30	O-ring	1

Sealing Parts List

No.	13	14	15	17	18	19	21	24	25	30
Standard	JIS B2401 1A		JIS B2401 1B	JIS B2401 1A	Special packing NBR	Special packing non asbestos	O-ring for centrifuge			
Model code	JIS B2401 1A		JIS B2401 1B	JIS B2401 1A	Special packing NBR	Special packing non asbestos	O-ring for centrifuge			
FP-1500S-1010	P32	G80	G140	P18	P14	t3x Ø213/ Ø167	t1.5x Ø106/ Ø96	For rotor	For cover	For cover nut

Model Code of Spare Parts

Replacement element

No.	Item	Element model	Filtration rating	Remarks
3	Water absorption element	P-AN-03100-W	For water absorption	
4	Filter element	P-GF-A-08-3-3C	3µm	With O-ring
		P-GF-A-08-3-8C	8µm	
23	Paper insert	FM060	For centrifuge	25 sheets/sets

SHELL AND TUBE TYPE : FCF SERIES

Water-Cooled Shell and Tube type
 Compact Oil Cooler Fixed Tube Sheet type
 Heat exchange amount : ~ 119.8kW

- Ø9 Low Fin Tube enables high cooling performance and downsizing
- Wide size variation allows to appropriate model selection
- High flexibility of installation by selectable flow direction and adjustable U-bolt stand
- Fixed tube sheet type is the simplest structure and low price

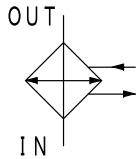

Water-cooled type cooler

FILTRATION & HEAT EXCHANGER

Specification

		Shell side		Tube Side	Shell size code				
					00□	1□□	2□□	3□□	4□□
Max working pressure	MPa	1.0		1.0	Cooling tube type				
Working temperature	°C	100*1		60	Ø9 Low Fin Tube *				
Pass structure		1 pass		2 passes	Main material	Cooling tube			
Fluid type	Standard	Mineral oil		Fresh water		Phosphorous-deoxidized copper			
	G	Water glycol fluid				Body		STKM, SS	STK, SS
			Fatty ester fluid		Chanel				
					FC				
					Coating	Outside coating			
						Aqua blue			
					Inside of channel				
					Tar-free epoxy coating				

* TASEI original high performance cooling tube enables 20% size reduction compared with general Ø12.7 low fin tube.

Model Code

(Model code example)



Code	Fluid type (Shell side)
Blank	Mineral oil
G	Water-glycol fluid
	Fatty ester fluid

Code	Heat transfer area	Shell size	Code	Heat transfer area	Shell size
003	0.15 m ²	Ø63.5	350	2.5 m ²	Ø139.8 (125A)
006	0.3 m ²		370	3.5 m ²	
108	0.4 m ²		390	4.5 m ²	
114	0.7 m ²	311	5.5 m ²		
122	1.1 m ²	313	6.5 m ²		
226	1.3 m ²	314	7.0 m ²		
234	1.7 m ²	316	8.0 m ²		
242	2.1 m ²	411	5.5 m ²	Ø165.2 (150A)	
256	2.8 m ²	414	7.0 m ²		
270	3.5 m ²	416	8.0 m ²		
		418	9.0 m ²		
		420	10.0 m ²		

Code	Flow rate*2
0	Large
1	medium
2	Small

* 1 Temperature difference between shell side fluid and tube side fluid should be within 80°C. If it is larger than 80°C, please select FCD model.

* 2 "Flow rate" is for optimization of flow velocity by adjusting the number of baffle plate depend on flow amount variation.

AIR-COOLED TYPE : ATK SERIES

Air-Cooled type Compact Oil Cooler Plate fin type
Heat exchange amount : ~ 2.1kW

- Light weight aluminum radiator
- Electric connection is selectable from DIN connector and lead wire
- Power connection is selectable from DIN connector and cable
- Fan motor is selectable from single phase AC 100V and 200V
- Other special specification is available : Different AC voltage or DC motor
 - ※ Shape and each specification are different with standard model.



FILTRATION & HEAT EXCHANGER

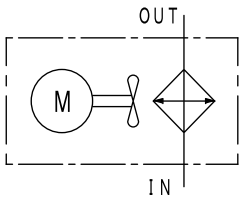

Air-cooled type cooler

Specification

Max working pressure*1	MPa	1.0
Max Working temperature	Inside of tube	°C 100
	Outside of tube	°C 60
Ambient conditions	Temperature	°C - 10 ~ 60
	Relative humidity	% RH35 ~ 85
	Place of installation	Indoor*2
Fluid type	Mineral oil, Water glycol fluid*3	

Model code		1552FA	2032FA	2432FA
Material	Radiator	Aluminum		
	Support	Steel plate		
Coating	Radiator	Black		
	Fan motor • Support	Black		
	Fan guard	Plating		
Weight (With connector)	kg	3.3(3.4)	3.2(3.3)	5.7(5.9)

Model code	Frequency (Hz)	Rated voltage (V)	Rated current (A)	Maximum load current (A)	Sound level *4 (dB)	Standard
ATK-□□□□FA-□□-1	50 / 60	100	0.52 / 0.44	0.61 / 0.51	56 / 58	UL • TUV
ATK-□□□□FA-□□-2		200	0.26 / 0.22	0.3 / 0.27		
ATK-□□□□FA-□□-15		115	0.36 / 0.3	0.42 / 0.41		
ATK-□□□□FA-□□-12		120	0.45 / 0.37	0.52 / 0.5		
ATK-□□□□FA-□□-22		220	0.23 / 0.19	0.27 / 0.23		
ATK-□□□□FA-□□-23		230	0.21 / 0.17	0.25 / 0.22		
Common to all models		Single phase, 2P, Built-in thermal protection				

Model Code

(Model code example)

ATK - **2032FA** - **03** - **A** - **2**

Code	Heat transfer area
1552FA	1.18m ²
2032FA	1.21m ²
2432FA	2.36m ²

Code	Connection diameter
02	Rc 1/4
04	Rc 1/2
03	Rc 3/8
04	Rc 1/2
03	Rc 3/8

Code	Connector
Blank	Non
A	Connector

Code	Fan motor voltage	
1	100V	Standard
2	200V	
15	115V	Special specification ※
12	120V	
22	220V	
23	230V	

※ Since price and lead time of different voltage type (special specification) are different with standard type, please ask us.

* 1 Allowable pressure fluctuation range is within 0.3MPa when using in a hydraulic circuit with repeated pressure fluctuation.

* 2 Please ask us in advance if you use in an environment with oil mists * 3 Please be sure that using fluid is not aluminum corrosive

* 4 Noise value of fan motor only (from manufacturer's catalog). It is not from cooler assembly.

AIR-COOLED TYPE : ATS SERIES

Air-Cooled type Middle/Large-sized Oil Cooler Plate fin type
Heat exchange amount: ~ 83.9kW

- Various sizes suitable for application from hydraulic power units to large lubrication machines
- Various installation types are available: Horizontal, Vertical, and Built-in
- Fan motor is selectable from 3 phase AC 300V class and 400V class
- 2 pass model is available for small oil flow rate (ATS-30, 35, 40 only)

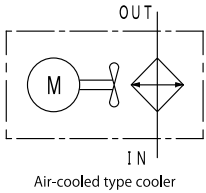

Specification

Max working pressure*2	MPa	1.0
Max Working temperature	Inside of tube	°C 150
	Outside of tube	°C 50
Ambient conditions	Temperature	°C ATS-30 ~ 40 -10 ~ 50 ATS-70 ~ 100 -30 ~ 50
	Relative humidity	% ≤RH90
	Place of installation	Indoor*3
Fluid type		Mineral oil, Water glycol fluid*4
Material	Radiator	Aluminum
	Case • Guard	Steel plate

Model code		306□-H	356□-H	406□-H	306□-V	356□-V	406□-V
Coating	Radiator	Black					
	Fan motor	Ivory					
	Case, Guard	Ivory					
Weight	kg	16	21	28	17	22	30
Model code		70101A-H	70101A-V	80101A-H	100101A-H		
Coating	Radiator	Black					
	Fan motor	Ivory					
	Case, Guard	Ivory					
Weight	kg	113	113	140	240		

Model code	Frequency (Hz)	Rated voltage (V)	Rated current (A)	Rated power (W)	Sound level*5 (dB)
ATS-306□ 200V class	50 / 60	200 ~ 220	0.21 ~ 0.23 / 0.20 ~ 0.21	25	38.5 / 41.5
ATS-306□ 400V class		380-400-415 / 380-400-440	0.10-0.10-0.104 / 0.094-0.10-0.10		
ATS-356□ 200V class		200 ~ 220	0.33 ~ 0.37 / 0.29 ~ 0.31	50	43.0 / 46.0
ATS-356□ 400V class		380-400-415 / 380-400-440	0.16-0.17-0.18 / 0.14-0.15-0.15		
ATS-406□ 200V class		200 ~ 220	0.63 ~ 0.75 / 0.52 ~ 0.56	100	47.0 / 51.0
ATS-406□ 400V class		380-400-415 / 380-400-440	0.29-0.32-0.33 / 0.25-0.26-0.28		
ATS-70101A 200V class		200 ~ 220	1.55 ~ 1.65 / 1.90 ~ 1.88	750	49.5 / 53.5
ATS-70101A 400V class		380-400-415 / 400 ~ 440	0.78-0.80-0.82 / 1.91 ~ 1.91		
ATS-80101A 200V class		200 / 200 ~ 220	5.60 / 5.30 ~ 5.50	1500	64.5 / 68.0
ATS-80101A 400V class		380-400-415 / 400 ~ 440	2.60-2.80-2.90 / 2.70 ~ 2.80		
ATS-100101A 200V class		200 / 200 ~ 220	5.80 / 6.30 ~ 6.30	2200	69.0 / 73.0
ATS-100101A 400V class		380-400-415 / 400 ~ 440	2.80-2.90-3.00 / 3.15 ~ 3.00		
Common to all models Three phase, 4P, Built-in thermal protection (except 400V class and ATS-80101A/100101A), UL • TUV standard and other special spec are available					

Model Code

(Model code example)

ATS - **3062** - M **①** **②** **②** **④** (ATS-30, 35, 40)

Code	Heat transfer area	Pass number	Code	Heat transfer area	Pass number
3061	2.9 m ²	1	70101A	32.8 m ²	1
3062		2	80101A	41.5 m ²	1
3561	4.5 m ²	1	100101A	66.5 m ²	1
3562		2			
4061	6.8 m ²	1			
4062		2			

(ATS-70) **①** **R** **G** **④**

(ATS-80, 100) **H** **G** **④**

① Code	Installation type	② Code	Radiator guard	③ Code	Fan guard	④ Code	Motor voltage
H	Horizontal stand	R	Radiator guard	G	Fan guard	2	200V class
V	Vertical stand	N	Non	N	Non	4	400V class
N*6	No stand						

* ATS-70,80,100 : Radiator and fan guard are included in standard equipment.

- * 1 Only horizontal installation type for ATS-80, 100.
- * 2 Allowable pressure fluctuation range is within 0.3MPa when using in a hydraulic circuit with repeated pressure fluctuation.
- * 3 Please ask us in advance if you use in an environment with oil mists
- * 4 Please be sure that using fluid is not aluminum corrosive
- * 5 Noise value of fan motor only (from manufacturer's catalog). It is not from cooler assembly.
- * 6 Only for ATS-30, 35, 40.



HYDRAULIC CYLINDER

COMPACT TYPE CYLINDER : CSR SERIES

43

TIE ROD TYPE : FF SERIES

45

TIE ROD TYPE : TR SERIES

48

COMPACT TYPE CYLINDER : CSR SERIES

Easy Maintenance

The packing can be changed by simply loosening the rod bushing without having to remove the main unit or disconnecting lines - the ultimate in easy maintenance

Innovations that make installation a breeze

The attachment holes have been recessed to hide the cap bolts in the cylinder main unit. They can be attached from either the front or the rear.
A parallel key has been attached in the Foot type, thereby eliminating the need for positioning



Specification

Series Name	CSR	
Mounting	SA-FA-FB	LD
Bore	Ø32- Ø40- Ø50- Ø63- Ø80	Ø32- Ø40- Ø50- Ø63
Nominal Pressure ^{Note1)}	16MPa	
Maximum Allowable Pressure ^{Note2)}	16MPa	
Proof Pressure	21MPa	
Minimum Operating Pressure ^{Note3)}	0.64MPa or less	
Range of Operating Speed ^{Note4)}	8 to 100mm/sec	
Range of Operating Temperature ^{Note5)}	Standard Specifications : -10°C to +80°C High Temperature Specification : -10°C to +100°C	
Cushion	None	
Hydraulic Oil Applied	General Purpose Mineral Hydraulic oil	
Thread Tolerance ^{Note6)}	JIS 6g / 6H	
Stroke Tolerance	100st or less : 0 to +0.8mm 101st to 250st : 0 to + 1.0mm	
Rod End Type	Female Thread or Male Thread	

- Note 1) Dimensions of the special model are different from those of the standard model.
- Note 2) The Maximum Allowable Pressure is the tolerance value for pressures, such as surge pressures and increased pressures, in the hydraulic cylinder circuit that exceed the pressure set for operation. Note 3) When operating at the maximum cylinder speed, keep the inertial load pressures generated within the cylinder chamber below Maximum Allowable Pressure.
- Note 4) The Minimum Operating Pressure is the value when the pressure is supplied from the cap side. Note 5) In the switch adjusted type, the temperature limit for the switch body should be under 60°C. (Select a special high-temperature switch in the case where temperatures will exceed 60°C) The high temperature specifications for the switch adjusted type vary with the packing/switch specifications so please contact us for usage details.
- Note 6) The female thread is a metric coarse thread. Note 7) None of these cylinders have air bleeds. Note 8) Radial loads cannot be applied to the piston rod, so care is necessary when adjusting them during installation.
- Note 9) In the case where the piston strikes the cylinder end surface at the end of the stroke, reduce the speed to below the minimum speed.
- Note 10) When tightening a double rod piston rod, always use the double surface width side of the rod for tightening. The double rod type of piston rod ends with a thread, so make sure that the torque does not affect the ends of the piston rods.

Stroke Table : Single Rod

Units : mm

Type	Mounting	Bore	Stroke																	Male Thread Specifications	Maximum Stroke					
			10	15	20	25	30	35	40	45	50	55	60	65	70	75	80	85	90			95	100			
CSR	SA FA FB	Ø32	⊙	⊙	⊙	⊙	⊙	⊙	⊙	⊙	⊙	○	○	○	○	○	○	○	○	○	○	○	○	○	200	
		Ø40	⊙	⊙	⊙	⊙	⊙	⊙	⊙	⊙	○	○	○	○	○	○	○	○	○	○	○	○	○	○	○	250
		Ø50	⊙	⊙	⊙	⊙	⊙	⊙	⊙	⊙	○	○	○	○	○	○	○	○	○	○	○	○	○	○	○	250
		Ø63	⊙	⊙	⊙	⊙	⊙	⊙	⊙	⊙	○	○	○	○	○	○	○	○	○	○	○	○	○	○	○	250
		Ø80	⊙	⊙	⊙	⊙	⊙	⊙	⊙	⊙	○	○	○	○	○	○	○	○	○	○	○	○	○	○	○	250
	LD	Ø32	⊙	○	⊙	○	⊙	○	⊙	○	⊙	△	○	△	○	△	○	△	○	△	○	○	○	○	○	200
		Ø40	⊙	○	⊙	○	⊙	○	⊙	○	⊙	△	○	△	○	△	○	△	○	△	○	○	○	○	○	250
		Ø50	⊙	○	⊙	○	⊙	○	⊙	○	⊙	△	○	△	○	△	○	△	○	△	○	○	○	○	○	250
		Ø63	⊙	○	⊙	○	⊙	○	⊙	○	⊙	△	○	△	○	△	○	△	○	△	○	○	○	○	○	250
		Ø80	⊙	○	⊙	○	⊙	○	⊙	○	⊙	△	○	△	○	△	○	△	○	△	○	○	○	○	○	250

Stroke Table : Double Rod

Units : mm

Type	Mounting	Bore	Stroke																	Male Thread Specifications	Maximum Stroke				
			10	15	20	25	30	35	40	45	50	55	60	65	70	75	80	85	90			95	100		
CSR	SA	Ø32	⊙	○	⊙	○	⊙	○	⊙	○	⊙	△	△	△	△	△	△	△	△	△	△	△	△	○	100
		Ø40	⊙	○	⊙	○	⊙	○	⊙	○	⊙	△	△	△	△	△	△	△	△	△	△	△	△	○	110
		Ø50	⊙	○	⊙	○	⊙	○	⊙	○	⊙	△	△	△	△	△	△	△	△	△	△	△	△	○	140
		Ø63	⊙	○	⊙	○	⊙	○	⊙	○	⊙	△	△	△	△	△	△	△	△	△	△	△	△	○	170
		Ø80	⊙	○	⊙	○	⊙	○	⊙	○	⊙	△	△	△	△	△	△	△	△	△	△	△	△	○	200
	LD	Ø32	⊙	○	⊙	○	⊙	○	⊙	○	⊙	△	△	△	△	△	△	△	△	△	△	△	△	○	100
		Ø40	⊙	○	⊙	○	⊙	○	⊙	○	⊙	△	△	△	△	△	△	△	△	△	△	△	△	○	110
		Ø50	⊙	○	⊙	○	⊙	○	⊙	○	⊙	△	△	△	△	△	△	△	△	△	△	△	△	○	140
		Ø63	⊙	○	⊙	○	⊙	○	⊙	○	⊙	△	△	△	△	△	△	△	△	△	△	△	△	○	170
		Ø80	⊙	○	⊙	○	⊙	○	⊙	○	⊙	△	△	△	△	△	△	△	△	△	△	△	△	○	170

Note 1) Standard ⊙. Standard Equivalent ○. Special Order △
 Note 2) The interval stroke of the multiples of 5 indicated by the O mark have external dimensions 5mm longer than the standard stroke. Example: The 15 stroke would have the external dimensions of the 20 stroke.

Packing Material

Code	8 (Standard)	6 (Coolant Proof Specifications)	9 (Standard)
Material	Nitrile Rubber + Urethane rubber	Nitrile Rubber + Urethane rubber	Hydrogenated Nitrile Rubber
Range of Operating Temperature	-10°C to +80°C	-10°C to +80°C	-10°C to +120°C
General-purpose Mineral Hydraulic Oil	◎	◎	○
Emulsions of Water in Mineral Oil	△	△	◎
Emulsions of Mineral Hydraulic Oil in Water	△	△	◎
Water+Glycol-type Operating Oil	X	X	◎
Phosphate Ester Fluid	X	X	X
Fatty Acid Ester Fluid	X	X	△

Piston Area

Bore (mm)	Rod Diameter (mm)	Piston Area (cm ²)			
		Single Rod		Double Rod	
		Push	Pull	Push	Pull
Ø32	Ø18	8.04	5.5	5.50	
Ø40	Ø22.4	12.57	8.63	8.63	
Ø50	Ø28	19.63	13.48	13.48	
Ø63	Ø35.5	31.17	21.27	21.27	
Ø80	Ø45	50.27	34.36	34.36	

Note 1) ○ - ◎ mark can be used. X mark cannot be used.
Please consult about △ mark separately.
Note 2) Urethane is contained in the piston packing of 8 (standard) and 6 (coolant-proof specification).
Note 3) Packing quality of the material 9: In selection of hydrogenated nitrile rubber, packing exchange cannot be performed of a visitor.

Code

CSR - S B 8 SA 32 B 10 - 2 C - M N YP
 ① ② ③ ④ ⑤ ⑥ ⑦ ⑧ ⑨ ⑩ ⑪ ⑫ ⑬

① Series Name	CSR : Switch adjusted type
② Single/Double Classification	S: Single Rod Type W: Double Rod Type (Special Order)
③ Standard Special Classification	A: Standard Dimensions B: In the cases of form with the length of a screw, size, and a special tip, etc. E: When attachment lug, tip metal fittings, etc. are special
④ Packing Material	8. Nitrile Rubber (Standard) 6. Coolant Proof Nitrile Rubber + Urethane rubber 9. Hydrogenated Nitrile Rubber (Standard)
⑤ Mounting	SA-FA-FB-LD (A key is included as an attachment)
⑥ Bore (mm)	Ø32-Ø40-Ø50-Ø63-Ø80 (There is no Ø80 Foot Type)
⑦ Type of Rod	B: B Rod
⑧ Stroke Length (mm)	10-15-20-25-30-35-40-45-50-60-70-80-90-100
⑨ Switch Quantity	Mention the quantity. 1A: In cases where a switch is not required. 1A2: For cylinder using CW or CX or WH or XH, No switch required. 1A3: For cylinder using SV or SH, No switch required.
⑩ Switch	C : TOV3 J : TOV5 CK: T5V3 CL: T5V5 DT: T2V3 DU: T2V5 CW: T2YV3 CH: TOH3 JH: TOH5 FJ: TOV-0.5 (For a DC connector system) FW: TOV-0.5 (For an AC connector system)XX: Special Part
⑪ Thread Specifications	M: Male Thread Specifications, No Notation: Female Thread Specifications (Standard) *In the case of double rods: male threads M, Male Thread: L, is notated as MM, LL, ML, etc.
⑫ Lock Nut	N: With Lock Nut; No Notation: None (this is an option of male thread specifications are used)
⑬ Rod End Joint	YP: Double Protrusion End Joint with Pin T: Single Protrusion End Joint (this is an option of male thread specifications)

Mass Table

Unit : kg

Symbol	CSR							
	SA				LD			
	Single Rod		Double Rod		Single Rod		Double Rod	
	Basic Mass	Stroke Mass	Basic Mass	Stroke Mass	Basic Mass	Stroke Mass	Basic Mass	Stroke Mass
Ø32	0.77	0.10	1.09	0.11	0.90	0.11	1.38	0.13
Ø40	1.03	0.12	1.48	0.15	1.30	0.15	2.00	0.18
Ø50	1.50	0.15	2.11	0.20	1.91	0.19	2.91	0.24
Ø63	2.32	0.21	3.28	0.29	3.03	0.27	4.66	0.35
Ø80	4.57	0.31	6.51	0.44	—	—	—	—

Note) The stroke mass is the mass per 10mm of stroke.

TIE ROD TYPE : FF SERIES

Excellent Dependability

The sliding part of the rod is of high-quality chrome-plated construction and a soft bronze casting is used for the rod bushing to prevent scarring of the rod with high performance U-shape packing used as the rod packing. These features provide reliability and durability while protecting against oil leakage.

Perfect Cushion Construction

Tapered cushion construction is incorporated into our standard cylinders and results in an approximate reduction of 50% of surge pressure as compared to conventional cylinders. This cushion construction provides ideal smooth stoppage over a very short time.

Switch adjusted

Our high-performance reliable dustproof switches (magnetic proximity switches) are standard. Because of their unified compact construction, there is no need to attach external sensors, thereby making cylinder installation very efficient.



HYDRAULIC CYLINDER



Series Name	F	
Nominal Pressure	7MPa : FS	14MPa : FF
Model	Standard : FS,FF	Switch adjusted : FSR, FFR
Bore	Ø32-Ø40-Ø50-Ø63-Ø80-Ø100 Ø125-Ø140-Ø150-Ø160-Ø180 Ø200-Ø224-Ø250	Ø32-Ø40-Ø50-Ø63-Ø80-Ø100 Ø125-Ø140
Maximum Allowable Pressure	7MPa Cap Side : 8.8MPa Head Side : Rod Type A14.7MPa, Rod Type B12.7MPa, Rod type C10.8MPa 14MPa Cap Side : 17.7MPa Head Side : Rod Type A17.7MPa, Rod Type B17.7MPa, Rod Type C13.7MPa	
Proof Pressure	FS : 10.5 MPa	FF : 21 MPa
Minimum Working Pressure	FS : Less than 0.29MPa	FF : Less than 0.56MPa
Thread Tolerance	JIS6g/6H (Corresponds to JIS Greade 2)	
Range of Operating Temperature	Standar Specifications : -10°C to 80°C High Temperature Specifications : -10°C to + 120°C	Standard Specification : -10°C to + 60°C High Temperature Specifications : -10°C to + 100°C
Hydraulic Oil Applied	General purpose mineral hydraulic oil	
Adjustment Standard	Governed by Former JIS B 8354	

Ranges of Operating Speed

Bore	Range
Ø32 to Ø63	8 to 400mm/S
Ø80 to Ø125	8 to 300mm/S
Ø140 to Ø250	8 to 200mm/S

Maximum Stroke

Bore	Maximum Stroke
Ø32	1,200mm
Ø40 or Ø50	1,500mm
Ø63 or Ø80	1,600mm
Ø100 to Ø250	2,000mm

Mounting Type

Format	Code		Format	Code	Appearance
Basic	S		Cap Side Square Flange ^{Note1)}	FD	
Axial Right Angle Direction Foot	LA		Middle Rectangular Flange	CF	
Axis Direction Foot (Only for 7 MPa)	LB		Single Protrusion Clevis	CA	
Axis Direction Foot	LC		Double Protrusion Clevis	CB	
Head Side : Rectangular Flange	FA		Spherical Bearing Single Protrusion Clevis	CC	
Cap Side Rectangular Flange	FB		Head Side Integral Trunnion	TA	
Head Side : Square Flange ^{Note1)}	FC		Middle Trunnion	TC	

Note 1) In the case of the Ø32 cylinder, the FC Format and the FD Format are considered to be non-standard.

Note 2) ABCD are the positioning relationships for the port valve, etc.

Cover Securing Formats

Securing Format	Appearance
Tie-rod System	

Packing Material

Code	1	2	3	9
Material	Nitrile Rubber	Urethane Rubber ^{Note 2)}	Fluoric Rubber ^{Note 3)}	Hydrogenated Nitrile Rubber
Range of operating temperature	-10°C to + 80°C	-10°C to +80°C	-10°C to + 120 °C	-10°C to + 120°C
General-purpose mineral hydraulic oil	○	◎	○	○
Emulsion of water in mineral oil	○	△	○	◎
Emulsion of mineral oil in water	○	△	○	◎
Water + Glycol-type Operating Oil	○	×	×	◎
Phosphate Ester fluid	×	×	○	×
Fatty Acid Ester fluid	○	×	△	△

Note 1) The ◎ or ○ mark indicates its use is possible. The X mark indicates it is not possible to use it.
Regarding the △ mark, consult us for details. The ◎ mark indicates the packing material recommended for applications where wear resistance is important.

Note 2) Urethane rubber specifications for Ø40C rods and Ø32 use cannot be produced.

Note 3) Specifications for fluoric rubber for Ø32C rods/nitrile rubber specifications for use in high temperature cannot be produced.

Note 4) Nitrile rubber for coolant proof applications is identified by a '6', and the fluoric rubber by a '7'.

Code

The switch codes are not necessary for the standard specifications.

FS- SA 1 TC 100 B B 320 A B D- -Y P N J
 FFR-SA 1 TC 100 B B 320 A B D- 2C-Y P N J

① ② ③ ④ ⑤ ⑥ ⑦ ⑧ ⑨ ⑩ ⑪ ⑫ ⑬ ⑭ ⑮ ⑯ ⑰ ⑱

①	Series Name	FS: 7 MPa, FF: 14MPa
②	Switch Adjusted Specifications	"R" is affixed in the case of cylinders with switch adjusted specifications. FSR: 7MPa switch adjusted specifications; FFR: 14MPa switch adjusted specifications
③	Single/Double Classification	S: Single Rod Type W: Double Rod Type
④	Standard Special Classification	A: Standard Dimensions
⑤	Packing Material	1. Nitrile Rubber (Standard) 2. Urethane Rubber 3. Fluoric Rubber 6. Coolant Proof Nitrile Rubber 7. Coolant Proof Fluoric Rubber 9. Hydrogenated Nitrile Rubber
⑥	Mounting	S· LA· LB· LC· FA· FB· FC· FD· CF· CA· CB· CC· TA· TC
⑦	Bore (mm)	32· 40· 50· 63· 80· 100· 125· 140· 150· 160· 180· 200· 224· 250 (Specifications for switch adjusted: Ø32 to Ø140: Ø32 to Ø180 is standard for the Double Rod Type. The Double Rod Type with switch adjusted specifications is standard).
⑧	Type of Rod	A: A Rod (Standard Equivalent) B: B Rod (Standard) C: C Rod (Standard)
⑨	Cushion Format	B: Cushion on Both Sides R: Head-side Cushion H: Cap-side Cushion N: No Cushion
⑩	Stroke Length (mm)	Indicate the stroke
⑪	Port location	Then indicate A, B, C or D.
⑫	Cushion Valve Location	Then indicate A, B, C or D. O: No Cushion or Fixed Cushion
⑬	Air Bleed Location	Then indicate A, B, C or D. No notation: Not necessary (Standard Equivalent)
⑭	Switch Quantity ^{Note 2)}	Mentioned the quantity. 1A. When the switch is not needed in a switch-adjusted specifications.
⑮	Switch Type	C:T0V3 J:T0V5 CK:T5V3 CL:T5V5 DT:T2V3 DU:T2V5 CW:T2YV3 CH:TOH3 JH:TOH5 FJ:TOV-0.5 (For a DC connector system) FW:TOV-0.5 (For an AC connector system) XX: Special Part
⑯	End Joint	T: Single Protrusion End Joint Y: Double Protrusion End Joint S: Spherical Bearing End Joint F: F Connector No notation: None
⑰	Pin	P: CB or the Y joint has a pin attached P2: CB and the Y joint have a pin attached G: Pin with Grease Nipple No notation: None } (at Ø125 or less, the pin is attached as standard equipment)
⑱	Lock Nut	N: Available (3 types) N2: Two lock nuts (3 types x 2 pieces) No notation: None
⑲	Bellows	J: Neoprene JS: Silicon Glass Cloth JA: Aluminum Foil Glass Cloth JC: Conex No notation: None (In the case where there are any other material specifications, please specify them).

TIE ROD TYPE : TR SERIES

Excellent Dependability

To prevent damage to the rod, the rod sliding surface is plated with high-quality chromium, and soft high strength brass is used for the rod bush. Also, high-performance U- packing is used for the rod packing. Back-pressure preventive grooved packing is used for the piston packing. Thus, the T series provides high reliability against oil leak and durability.

Certain steady operation

The piston uses a wear ring to prevent seizure, ensuring improved reliability. The cushion mechanism provides high accuracy, enabling reliable operation.



Specifications

Series Name	TR
Nominal Pressure	21MPa
Model	Switch adjusted : TR
Bore	Ø40- Ø50- Ø63- Ø80
Maximum Allowable Pressure	Cap Side: 26.5MPa Head Side: Rod Type A 26.5MPa, Rod Type B 24.5MPa
Proof Pressure	31.5MPa
Minimum Working Pressure	Less than 0.84MPa
Thread Tolerance	JIS6g/6H (Corresponds to JIS Grade 2)
Range of Operating Temperature	Standard Specifications : -10°C to +60°C High Temperature Specifications: -10°C to +100°C
Hydraulic Oil Applied	General purpose mineral hydraulic oil
Adjustment standard	Governed by Former JIS B 8354

Ranges of Operating Speed

Bore	Range
Ø40 to Ø63	8 to 400mm/s
Ø80 to Ø125	8 to 300mm/s
Ø140 to Ø250	8 to 200mm/s

Note) When operating at the maximum cylinder speed, Keep the inertial load pressures generated within the cylinder chamber below the Nominal Pressure.

Maximum Stroke : Tie Rod Type

Bore	Maximum stroke
Ø40 or Ø50	1,500mm
Ø63 or Ø80	1,600mm
Ø100 to Ø160	2,000mm
Ø180 to Ø250	1,500mm

Note 1) This is the Maximum Stroke for the standard item produced.
Note 2) Please consider the rod buckling separately.

Mounting Type

Format	Code	Diagram	Format	Code	Appearance
Basic	S Ø40 to Ø250		Single Protrusion Clevis	CA Ø40 to Ø250	
Axial Right Angle Direction Foot	LA Ø40 to Ø160		Double Protrusion Clevis	CB Ø40 to Ø160	
Head Side : Rectangular Flange	FA Ø40 to Ø250		Head Side Integral Trunnion	TA Ø40 to Ø250	
Cap Side : Rectangular Flange	FB Ø40 to Ø250		Middle Trunnion	TC Ø40 to Ø250	

Note 2) (A)(B)(C)(D) are the positioning relationships for the port valve, etc.

Packing Materials

Code	1	2	3	9
Material	Nitrile Rubber	Urethane Rubber	Fluoric Rubber	Hydrogenated Nitrile Rubber
Range of operating temperature	-10°C to +80°C	-10°C to +80°C	-10°C to +120 °C	-10°C to +120°C
General-purpose mineral hydraulic oil	○	◎	○	○
Emulsion of water in mineral oil	○	△	○	◎
Emulsion of mineral oil in water	○	△	○	◎
Water + Glycol-type Operating Oil	○	×	×	◎
Phosphate Ester fluid	×	×	○	×
Fatty Acid Ester fluid	○	×	△	△

Note) The ◎ or ○ mark indicates its use is possible. The X mark indicates it is not possible to use it.
 Regarding the △ mark, consult us for details. The ◎ mark indicates the packing material recommended for applications where wear resistance is important.

Theoretical Output Table

Bore	Rod Diameter (m)		Piston Area (cm ²)			Theoretical Output (N)		
	A Rod	B Rod	Push	Pull A Rod	Pull B Rod	Push	Pull A Rod	Pull B Rod
Ø40	28	22.4	12.5	6.4	8.6	26,380	13,450	18,110
Ø50	35.5	28	19.6	9.7	13.4	41,230	20,440	28,300
Ø63	45	35.5	31.1	15.2	21.2	65,460	32,060	44,670
Ø80	56	45	50.2	25.6	34.3	105,550	53,830	72,150
Ø100	71	56	78.5	38.9	53.9	164,930	81,790	113,210
Ø125	90	71	122.7	59.1	83.1	257,700	124,110	174,560
Ø140	100	80	153.9	75.3	103.6	323,260	158,330	217,710
Ø160	112	90	201.0	102.5	137.4	422,230	215,330	288,630
Ø180	125	100	254.4	131.7	175.9	534,380	276,670	369,450
Ø200	140	112	314.1	160.2	215.6	659,730	336,460	452,840
Ø224	160	125	394.0	193.0	271.3	827,570	405,340	569,860
Ø250	180	140	490.8	236.4	336.9	1,030,830	496,450	707,560

Code

T R - S A 2 TC 80 B B 300 A B D - 2 C - Y P N J
 ① ② ③ ④ ⑤ ⑥ ⑦ ⑧ ⑨ ⑩ ⑪ ⑫ ⑬ ⑭ ⑮ ⑯ ⑰ ⑱

①	Series Name	T: 21 MPa	
②	Switch Adjusted Specifications	"R" is affixed in the case of cylinders with switch adjusted specifications. :TR	
③	Single/Double Classification	S: Single Rod Type (Standard Type) W: Double Rod Type (Standard Equivalent)	
④	Standard Special Classification	A: Standard Dimensions	
⑤	Packing Material	1. Nitrile Rubber (Standard Type: Ø180 to Ø250) 2. Urethane Rubber (Standard Type: Ø40 to Ø160) 3. Fluoric Rubber 9. Hydrogenated Nitrile Rubber	
⑥	Mounting	S · LA · FA · FB · CA · CB · TA · TC · (Ø180 to Ø250, there is no LA and CB.)	
⑦	Bore (mm)	40 · 50 · 63 · 80 · 100 · 125 · 140 · 160 · 180 · 200 · 224 · 250 (Specifications for switch adjusted Ø40 to Ø80 is standard Type.)	
⑧	Type of Rod	A: A Rod B: B Rod (Standard)	
⑨	Cushion Format	B: Cushion on Both Sides R: Head-side Cushion H: Cap-side Cushion N: No Cushion	
⑩	Stroke Length (mm)	Indicate the stroke.	
⑪	Port location	Then indicate A, B, C or D.	
⑫	Cushion Valve Location	Then indicate A, B, C or D. O: No Cushion or Fixed Cushion	
⑬	Air Bleed Location	Then indicate A, B, C or D. - No notation: None (Standard Equivalent)	
⑭	Switch Quantity	Mentioned the quantity. 1A. When the switch is not needed in a switch-adjusted specifications.	
⑮	Switch Type	C:TOV3 J:TOV5 CK:TSV3 CL:TSV5 DT:T2V3 DU:T2V5 CW:T2VY3 CH:TOH3 JH:TOH5 FJ:TOV-0.5 (For a DC connector system) FW:TOV-0.5 (For an AC connector system) XX: Special Part	
⑯	End Joint	T: Single Protrusion End Joint Y: Double Protrusion End Joint No notation: None	
⑰	Pin	P: CB or the Y joint has a pin attached P2: CB and the Y joint have a pin attached	(at Ø125 or less, the pin is attached as standard equipment)
⑱	Lock Nut	N: Available (3 types) N2: Two lock nuts (3 types x 2 pieces) No notation: None	
⑲	Bellows	J: Neoprene JS: Silicon Glass Cloth JA: Aluminum Foil Glass Cloth No entry: None (In the case where there are any other material specifications, please specify them).	



MEASURING INSTRUMENT

DIGITAL FLOW SENSOR : DFS	51
DIGITAL PRESSURE SWITCH : DPS	52
GLYCERIN PRESSURE GAUGE : OPG Ø39	53
GLYCERIN PRESSURE GAUGE : OPG Ø60,Ø75,Ø100	54
COLOR RING FOR OPG Ø39 & 60 ONLY "CR-39/60"	55
LEVEL SWITCH [Flange Mounting] : LSN	56
TEMPERATURE SWITCH [From Tank Top] : TSF	57

DIGITAL FLOW SENSOR : DFS

Three functions: Flow switch, flow sight, and flow meter

- How to connect: M12 x1- 4 pin connector
- You can use this with an input power supply of from 12 to 24 V DC.
- Amplifier protection structure conforms to IP67 equivalent.
- You can set a lower limit of flow rate. If flow rate falls below the limit, you are warned by a red LED lamp and an output signal.
- In case of low-pressure spec, you can check flow of fluid by observing rotor rotation from a metal/plastic cap.
- In case of high-pressure spec, you can measure flow rate at 25MPa. (Except DFS-1) If you use DFS-2, 3, 6, or 8, You must use an all-metal cap for high pressure. Factory setting: all-metal cap for high pressure.
- You can select a position (horizontal, vertical, or tilted) to install.
- Rotor can be cleaned by air blow, after taking off a metal cap from a main body.



MEASURING INSTRUMENT

Body and overall specification

Model	DFS-1	DFS-2	DFS-3	DFS-6	DFS-8
Screw type (Both sides)	Rc 1/8	Rc 1/4	Rc 3/8	Rc 3/4	Rc 1
Max. flow rate (ℓ/min)	1	10	20	50	100
Measurement range (ℓ/min)	0.2~1	1~10	2~20	5~50	10~100
Max. pressure	3MPa	3MPa (if a metal/plastic cap is installed)			
		25MPa (if an all-metal cap is installed)			
Flow sight function	Available	Available (if a metal/plastic cap is installed.)			
		Not availabl (eif an all-metal cap is installed. *1)			
Accuracy *2	±0.1 ℓ/min	±0.5 ℓ/min	±1.0 ℓ/min	±2.5 ℓ/min	±5.0 ℓ/min
Fluid *3	Petroleum oil, Lubrication oil	Petroleum oil, Lubrication oil			
		Water, Water-soluble cutting oil			
Pressure loss *4	0.03MPa or less	0.025MPa or less			
Temperature	Fluid temp.: 0 ~ 80°C, Ambient temp.: 0 ~ 50°C				
Material	Fluid contact: C3604(Ni plating), Nd-Fe-B, POM, PC, NBR				

Amplifier specification

Model	DFS-1	DFS-2	DFS-3	DFS-6	DFS-8
Power	DC12V~24V				
Current	Max.100mA (Consumtion)				
Output	PNP open collector (factory setting) / NPN open collector (It can be changed arbitrarily.) Maximum load 100mA				
Connection	M12 X 1-4 pin connector (DC)				
Protection	IP67 equivalent				
Material	ABS, NBR, PA, Polyester				
Display *5	7-segment LED, 2 LEDs (Green/Red)				
*6 Output state	More than adjusted value: LED (Green) ON / LED (Red) OFF, Output ON Less than adjusted value: LED (Green) OFF / LED (Red) ON, Output OFF				

- * 1: You can't visually observe flow, when you use an all-metal cap.
- * 2: Guaranteed value at 32 cSt about O spec accuracy
- * 3: Ajustment depends on fluid which you use. Specify it when ordering.
- * 4: Indicated a value at 32 cSt, when max. flow rate.
- * 5: You can select non-display mode.
- * 6: You can set a lower limit of flow rate optionally. Regarding how to set, refer to an instruction manual.

Description

DFS - 2 - 0 - *

① ② ③ ④

①	Name	Digital flow sensor
②	Screw type (Both sides)	1 : Rc 1/8 2 : Rc 1/4 3 : Rc 3/8 6 : Rc 3/4 8 : Rc 1
③	Fluid	O: Petroleum oil, lubrication oil (DFS-1 : Only O type) W: Water, water soluble cutting oil
④	Custom spec	Please contact us.

DIGITAL PRESSURE SWITCH : DPS

Small, big LED display, and easy to connect by union screw

- Small type : Dimension \varnothing 38x40mm Weight : 186g
- LED display : Letter height: 11mm, 7-segment LED
- LED color : Red and Blue (※Blue is color universal design.)
- Connection : R 1/4 union screw
- Waterproof : IP67 equivalent
- Proof pressure : Quadruple (4 times)
- Material : Body SUS304, diaphragm SUS316
- Operation : 2 buttons
- ※Color universal design : Easy to look for many people without individual differences.



General specification

Model	DPS-1.0	DPS-2.5	DPS-10	DPS-16
Pressure range	0~1.0MPa	0~2.5MPa	0~10MPa	0~16MPa
Proof pressure	4MPa	10MPa	40MPa	64MPa
Dissolution	0.01MPa		0.1MPa	
Accuracy	$\pm 1.6\%$ F.S. ± 1 digit		$\pm 2\%$ F.S. ± 1 digit	
Screw type	R 1/4			
Ambient temp.	- 10 ~ 50°C			
Fluid temp.	- 10 ~ 70°C			
Fluid	Air, Water, Oil			
Main materials	SUS304, SUS316, FKM			
Protection	IP67 Equivalent			
Environment	RoHS			
Weight	186g (Cable not included)			

Electoric, output specification

Power source	DC12 ~ 24V
Max. current	Max. 30mA
Output	PNP open collector (factory setting)/ NPN open collector (It can be changed arbitrarily) Maximum load 100mA
Connection	M12x1-4 pins connector (DC)
Display	7-segment LED (Letter: 11mm)
Color	Red \leftrightarrow Blue ※
Pressure unit	MPa
Output display	1LED(Red)
Output state	LED (Red) ON / Output ON LED (Red) OFF / Output OFF
Mode	Hysteresis / Window comparator (※)
Function	Key lock, Zero set, "OL" indicator

※ Optional setting

Description

DPS - 10

- ① ②

①	Name	Digital pressure switch
②	Pressure range	1.0 : 0 ~ 1.0MPa 2.5 : 0 ~ 2.5MPa 10 : 0 ~ 10 MPa 16 : 0 ~ 16 MPa

Output

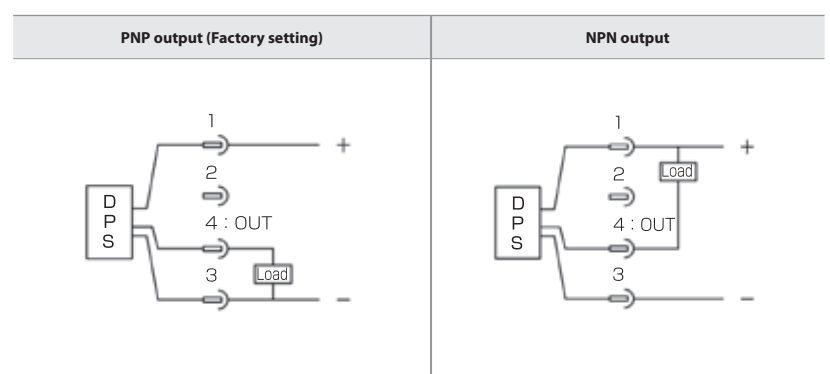

GLYCERIN PRESSURE GAUGE : OPG Ø39

A space-saving glycerin-filled pressure gauge with an outer diameter of Ø39 that can be directly screwed into a modular valve!

- Stainless steel case < improved corrosion resistance >
- Sealing of glycerin < improved pulsation effect >
- Safety mark provided as the standard
- Pressure scale of 270-degree angle



Specification

Fluid	Petroleum oil, Water-glycol based oil Phosphate ester oil, Water
Accuracy	± 3% / F.S.
Temp. range	- 5 ~ 40°C
Liquid	Glycerin 100%
Vibration range	0~7G
Weight	110g
Optional spec	<ul style="list-style-type: none"> • Color scale • Optional special scale

Description

OPG - DT - R1/4 - 39 × 10MPa - S -

① ② ③ ④ ⑤ ⑥ ⑦

①	Name	Glycerin pressure gauge
②	Profile	Center back mount Socket type : Square
③	Screw type	R 1/4 (PT)
④	Size	39 : Ø 39mm
⑤	Pressure range (Max. scale)	1 : 1 MPa 2.5 : 2.5 MPa 4 : 4 MPa 6 : 6 MPa 10 : 10 MPa 16 : 16 MPa 25 : 25 MPa 40 : 40 MPa
⑥	SUS case	
⑦	Color ring	No mark : Withoutt color ring, CR : With color ring (CR-39)

Socket

Socket shape to fix a pressure gauge with a spanner
 U type : Chamfering, T type : Square, S type : Hexagon

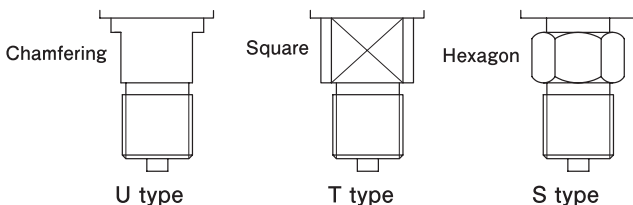

Screw type

Screw type		
Past		Present
Taper male screw	PT	R
Taper female screw		Rc
PF		G

GLYCERIN PRESSURE GAUGE : OPG Ø60,Ø75,Ø100

The glycerin-filled pressure gauge OPG series is a pressure gauge with excellent vibration resistance and durability

- Shaking of a pointer due to mechanical vibration is absorbed by viscous drag of glycerin into a gauge. Movement of a bourdon tube is also absorbed, improving absorption effect of pulsating pressure of fluid.
- Glycerin serves as lubricating oil for a friction part of a bearing and gear in a gauge, thereby improving the durability of the internal mechanism.
- Even if a bourdon tube is broken, a front plate isn't shattered, because oil is purged from a safety cap.
- You can easily set pressure range and setting value by green marks on a front plate. (Only for Ø60 gauge)
- Select a pressure gauge which has max pressure scale of 2 times more than your pressure range.

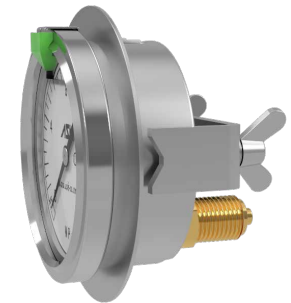

MEASURING INSTRUMENT



Specification

Fluid	Petroleum oil, Water-glycol based oil Phosphate ester oil, Water	
Accuracy	Ø60, Ø75, Ø100	± 1.6% / F.S.
Temp. range	- 5 ~ 40°C	
Indication error	±0.3% / 10°C	
Liquid	Glycerin	
Vibration range	0~7G	
Optional spec	<ul style="list-style-type: none"> • Color scale • Optional special scale • Cold climates spec (Temp. range -15~ 60°C, Silicon oil spec) 	

Description

OPG - A T - G1/4 - 60 × 10MPa - -

① ② ③ ④ ⑤ ⑥ ⑦ ⑧

①	Name	Glycerin pressure gauge
②	Profile	A : Frameless B : Round frame D : Back mount (With fitting)
③	Socket type	T : Square (Ø60, A and B Ø75) S : Hexagon (Ø100) U : Chamfering (D Ø75)
④	Screw type	G ¼ (Ø60) R ¼ (A Ø60) G ¾ (Ø75, Ø100)
⑤	Size	60 : (Ø60) 75 : Ø75mm 100 : Ø100m
⑥	Pressure range (Max. scale)	See model List.
⑦	Ø 60 D type	No mark : Other than Ø60 D type B : Ø60 D type
⑧	Color ring (Only Ø60)	No mark : Without color ring CR : With color ring (CR60)

* Contact us about a special gauge with a color scale. (Except for Ø60)
* Safety marks are not attached if you order a special gauge with a color scale.

COLOR RING FOR OPG Ø39 & 60 ONLY "CR-39/60"

Color range adjustment ring exclusively for glycerin pressure gauge "OPGØ39/Ø60" that can be adjusted on site

- Color ring is an optional product for our glycerin pressure gauges OPG Ø39 and Ø60.
- It is composed of 2 parts and the zone of red and green can be freely adjusted depending on how the parts are matched. (The green zone can be set from min 0 to max about 150 degrees.)
- Color ring can be installed on the current OPG Ø39, OPG Ø60 A, B, D and OSG Ø60. (It is for stainless steel case specification of OPG Ø39 and are for OPG Ø60 and OSG Ø60 which were manufactured after 2007.)
- Easy to install, Unnecessary modification. Compared to the hand-painted or sticker method, the operating time can be significantly reduced.
- Using oil-and coolant material-resistant.
- Completed of vibration resistance test. The item doesn't become loose due to mechanical vibration.

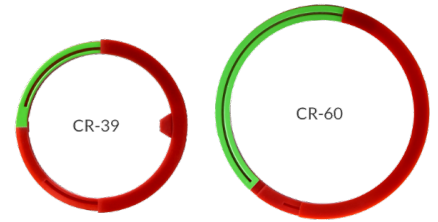

Explanation of model

CR - 39
① ②

①	Model	Color ring
②	Attachable pressure gauge	39 : OPG Ø39 60 : OPG Ø60 OSG Ø60

* There is also a part number with a pressure gauge. As for details, please refer to the model explanation of each pressure gauge.

Installation • Setting example

OPG Ø39		OPG Ø60	
Safety mark (Standard installation)	Color ring CR-39 (Option)	Safety mark (Standard installation)	Color ring CR-60 (Option)
Setting example : Green 3-4 MPa		Setting example : Green 4-8 MPa	

LEVEL SWITCH [FLANGE MOUNTING] : LSN

A level switch developed for detecting the liquid level of oil tanks and water tanks

- A compact, low-cost level switch that combines a high-precision reed switch and a float with a built-in magnet.
- Flanges with sturdy DIN connectors. Install from the top of the tank.
- We accept orders for detection liquid level depths in the range of L = 60 to 500mm in increments of 1mm.
- Stable operation is ensured because it is not affected by the temperature of the fluid in the tank.
- Equivalent to IP65 protection class.



Specification

	DC24V		AC100V	
	For oil	For water	For oil	For water
Mounting	Flange type			
How to wiring	DIN connector connection			
Contact capacity	1.2VA		2VA	
Contact resistance	Less than 1Ω			
Maximum operating voltage	DC24V		AC100V/110V	
Maximum operating current	0.05A DC		0.02A AC	
Minimum current load	5mA			
Insulation resistance	50mΩ or more by DC500V insulation resistance tester			
Withstand voltage	AC1000V / 1 min			
Surrounding temperature	-10°C~80°C			
Specific gravity of float	(0.47)	(0.7)	(0.47)	(0.7)
Ø d	26.5	28	26.5	28
(b)	(22.8)	(28.5)	(22.8)	(28.5)
Weight	130g (Without a pipe)			
Standard accessories	① Hexagon socket head bolt (M4X16) 2pcs ② O-ring (JIS B 2401 1A P-38) 1pcs			

Description

LSN - 200 L - A - - 11

① ② ③ ④ ⑤

①	Model	LSN : Flange type level switch	
②	Level length ※1	min. 60mm~max. 500mm (1 mm unit)	Setting accuracy ± 3mm
③	Contact type	H-A : ON above level (OFF below level) H-B : OFF above level (ON below level) L-A : ON below level (OFF above level) L-B : OFF below level (ON above level)	
④	Fluid	Unmarked : For oil (Standard specification : NBR float) W : For water (Option : SUS float)	
⑤	Model number	11: Standard specification (DC24V) 51: Standard specification (AC100V)	

※1 The liquid specific weight is a value of 1.0.

TEMPERATURE SWITCH (FROM TANK TOP) : TSF

This is a bimetal temperature switch developed to detect oil temperature in the oil tank

- Flanges with sturdy DIN connectors. Install from the top of the tank.
- Install the switch so that the entire switch body is immersed in water.
- The detection length from 90 to 500 mm, at an interval of 1 mm, is available.
- Equivalent to IP65 protection class.



MEASURING INSTRUMENT

Description

TSF - ※ X - 250 - 11

① ② ③ ④ ⑤

①	Name	TSF : Temperature switch (From tank top)
②	Setting temp.	45°C ~ 75°C (By the 5°C)
③	Contact type	X : Temp. rise / OFF Y : Temp. rise / ON
④	TSF length under flange	Min. 90mm ~ Max.500mm (By the 1 mm)
⑤	Model no.	11 : Standard spec

Setting temp. (Fixed at our factory)

Setting temp. range	45°C~75°C (By the 5 °C)	
Setting temp. rank	45°C~50°C	55°C~75°C
Temp. differential	±3°C	±4°C

Contact specification

Model	Contact type	Differential	Contact capacity	Min.current	Temp. tange	Contact life	Weight
TSF-※X-11	Temp. rise/OFF	45X~75X : 6.5 (5~8) °C 45Y~65Y : 4.5 (3~6) °C 70Y~75Y : 6.5 (5~8) °C	AC125V 1.5A DC 12V 1.5A AC250V 0.9A DC 24V 0.9A (Life : 100 thousand)	50mA	-20~105°C	Mechanical life : 2 million times Contact life : 100 thousand under max. load	Without a pipe 230g
TSF-※Y-11	Temp. rise/ON						



INDUSTRIAL HOSE : IBG SERIES

IBG35 / IBG70	60
IBG140	61
IBG210	62
IBG280	63
IBG320	64
IBG350	65

Type of hose			High Pressure Hose						
Capacity	Size I.D.	Dash	IBG						
	mm.		IBG 35	IBG 70	IBG 140	IBG 210	IBG 280	IBG 320	IBG 350
Max Working Pressure MPa	6	04		7.0	14.0	21.0	28.0	32.0	35.0
	9	06		7.0	14.0	21.0	28.0	32.0	35.0
	12	08		7.0	14.0	21.0	28.0		
	15	10		7.0	14.0	21.0			
	19	12		7.0	14.0	21.0			
	25	16		7.0	14.0	21.0			
	32	20	3.5	7.0	14.0				
	38	24	3.5	7.0	14.0				
	50	32	3.5	7.0	14.0				
	65	40		7.0		21.0			
Max Working pressure (MPa)			150%						
Min. Burst Pressure (MPa)			400%						
Operating Temperature (°C)			-40°C~+100°C						
Recommended Fluids			Mineral Synthetic Oil						
Usage			Hydraulic Machine						

Type of Hose		IBG 35	IBG 70	IBG 140	IBG 210	IBG 280	IBG 320	IBG 350
Type of Fitting	4	○	○	○	○	○	○	○
	5	○	○	○	○	○	○	○

IBG35 / IBG70

HOSE STRUCTURE

- INNER COVER : OIL RESISTANT SYNTHETIC RUBBER
- REINFORCEMENT : STEEL WIRE
- OUTER COVER : OIL & OZONE RESISTANT SYNTHETIC RUBBER

RECOMMENDED FLUIDS **OPERATING TEMPERATURE**
 MINERAL SYNTHETIC OIL -40°C ~ +100°C (-40°F ~ +212°F)

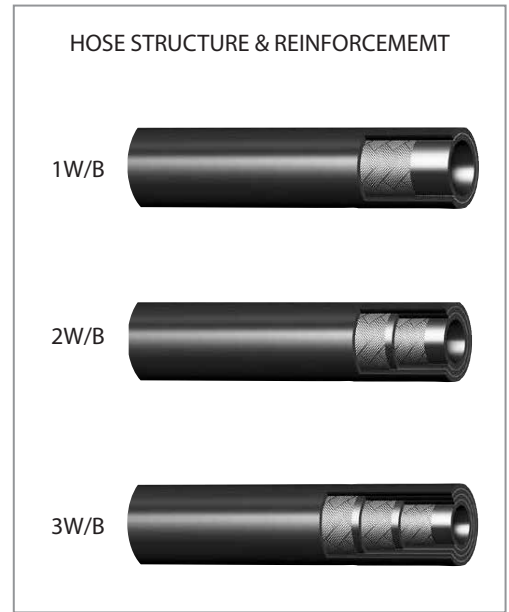

Model	Size	Reinforcement	Inner Diameter mm	Outer Diameter mm	Max Working Pressure MPa	Min. Burst Pressure MPa	Min. Bend Radius mm	Weight g/m
IBG 35	32	1W/B	31.8	41.1	3.5	14.0	210	945
	38	1W/B	38.1	47.4	3.5	14.0	240	1140
	50	1W/B	50.8	61.0	3.5	14.0	310	1685
IBG 70	6	1W/B	6.3	13.1	7.0	28.0	50	200
	9	1W/B	9.5	16.3	7.0	28.0	65	280
	12	1W/B	12.7	19.5	7.0	28.0	70	385
	15	1W/B	15.9	23.8	7.0	28.0	120	500
	19	1W/B	19.0	27.5	7.0	28.0	130	655
	25	1W/B	25.4	34.3	7.0	28.0	170	830
	32	2W/B	31.8	43.2	7.0	28.0	220	1455
	38	2W/B	38.1	50.1	7.0	28.0	260	1845
	50	2W/B	50.8	63.3	7.0	28.0	320	2525
	65	3W/B	63.5	82.4	7.0	28.0	650	4850

SIZE	A	B	C	D	E	H1	H2	L	Thread	Weight (g)
6	8.5	16.0	6	4.2	9.5	19	19	51	1/4	70
9	9.5	19.0	6	7.0	13.0	22	22	54	3/8	100
12	11.0	21.5	8	9.5	16.0	27	27	62	1/2	170
15	12.5	23.0	10	16.0	22.0	36	30	69	3/4	250
19	12.5	23.0	10	16.1	22.0	36	30	72	3/4	270
25	12.5	25.5	12	21.8	28.0	41	36	89	1	370
32	15.5	30.5	13	27.0	36.0	50	46	114	1 1/4	780
38	16.5	33.5	14	31.8	42.0	55	50	128	1 1/2	1250
50	18.0	37.0	19	42.0	54.0	70	65	150	2	2200
65	30.5	50.0	18	54.0	70.0	85	85	188	2 1/2	3400

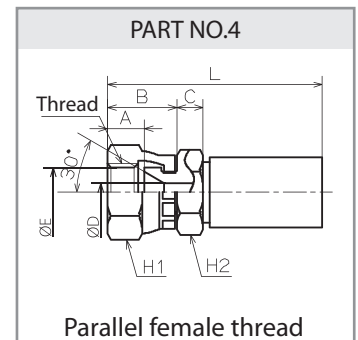

SIZE	A	B	C	D	E	H1	H2	L	Thread	Weight (g)
6	5.5	16.0	6	4.2	7.5	19	19	51	1/4	70
9	6.5	19.0	6	7.0	10.0	22	22	54	3/8	100
12	8.5	21.5	8	9.5	13.0	27	27	62	1/2	170
15	9.0	23.0	10	16.0	19.0	36	30	69	3/4	250
19	9.0	23.0	10	16.1	19.0	36	30	72	3/4	270
25	9.5	25.5	12	21.8	24.0	41	36	89	1	370
32	12.5	30.5	13	27.0	32.0	50	46	114	1 1/4	780
38	12.5	33.5	14	31.8	38.0	55	50	128	1 1/2	1250
50	15.0	37.0	19.0	42.0	49.0	70	65	150	2	2200
65	21.5	50.0	18	54.0	60.0	85	85	188	2 1/2	3400

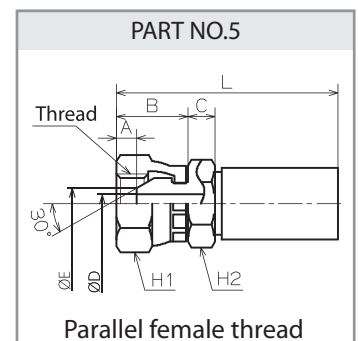

IBG140

HOSE STRUCTURE

- INNER COVER : OIL RESISTANT SYNTHETIC RUBBER
- REINFORCEMENT : STEEL WIRE
- OUTER COVER : OIL & OZONE RESISTANT SYNTHETIC RUBBER

RECOMMENDED FLUIDS **OPERATING TEMPERATURE**
 MINERAL SYNTHETIC OIL -40°C ~ +100°C (-40°F ~ +212°F)

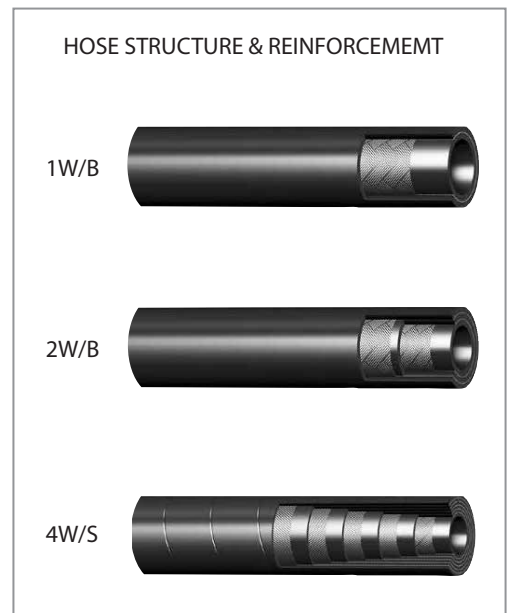

Size	Reinforcement	Inner Diameter mm	Outer Diameter mm	Max Working Pressure MPa	Min. Burst Pressure MPa	Min. Bend Radius mm	Weight g/m
6	1W/B	6.3	13.1	14.0	56.0	55	215
9	1W/B	9.5	16.4	14.0	56.0	70	295
12	1W/B	12.7	19.5	14.0	56.0	75	385
15	2W/B	15.9	25.0	14.0	56.0	110	715
19	2W/B	19.0	28.4	14.0	56.0	130	885
25	2W/B	25.4	34.8	14.0	56.0	170	1095
32	4W/S	31.8	44.5	14.0	56.0	230	2470
38	4W/S	38.1	53.6	14.0	56.0	270	3245
50	4W/S	50.8	66.7	14.0	56.0	350	4530

SIZE	A	B	C	D	E	H1	H2	L	Thread	Weight (g)
6	8.5	16.0	6	4.2	9.5	19	19	51	1/4	70
9	9.5	19.0	6	7.0	13.0	22	22	54	3/8	100
12	11.0	21.5	8	9.5	16.0	27	27	62	1/2	170
15	12.5	23.0	10	16.0	22.0	36	30	69	3/4	250
19	12.5	23.0	10	16.1	22.0	36	30	72	3/4	270
25	12.5	25.5	10	21.8	28.0	41	36	79	1	370
32	15.5	30.5	13	27.0	36.0	50	46	114	1 1/4	780
38	16.5	33.5	14	31.8	42.0	55	50	128	1 1/2	1250
50	18.0	37.0	19	42.0	54.0	70	65	150	2	2200

SIZE	A	B	C	D	E	H1	H2	L	Thread	Weight (g)
6	5.5	16.0	6	4.2	7.5	19	19	51	1/4	70
9	6.5	19.0	6	7.0	10.0	22	22	54	3/8	100
12	8.5	21.5	8	9.5	13.0	27	27	62	1/2	170
15	9.0	23.0	10	16.0	19.0	36	30	69	3/4	250
19	9.0	23.0	10	16.1	19.0	36	30	72	3/4	270
25	9.5	25.5	10	21.8	24.7	41	36	79	1	370
32	12.5	30.5	13	27.0	32.0	50	46	114	1 1/4	780
38	12.5	33.5	14	31.8	38.0	55	50	128	1 1/2	1250
50	15.0	37.0	19	42.0	49.0	70	65	150	2	2200

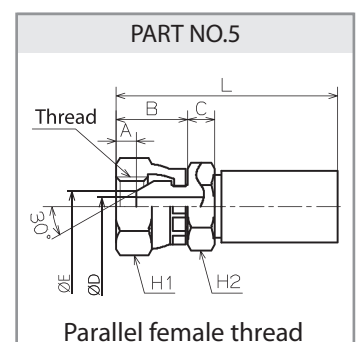
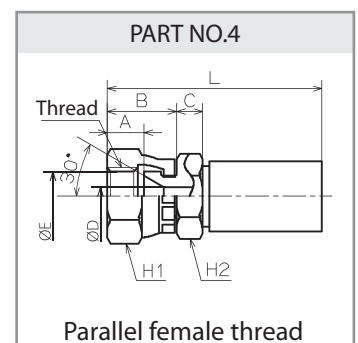

IBG210

HOSE STRUCTURE

- INNER COVER : OIL RESISTANT SYNTHETIC RUBBER
- REINFORCEMENT : STEEL WIRE
- OUTER COVER : OIL & OZONE RESISTANT SYNTHETIC RUBBER

RECOMMENDED FLUIDS **OPERATING TEMPERATURE**
 MINERAL SYNTHETIC OIL -40°C ~ +100°C (-40°F ~ +212°F)

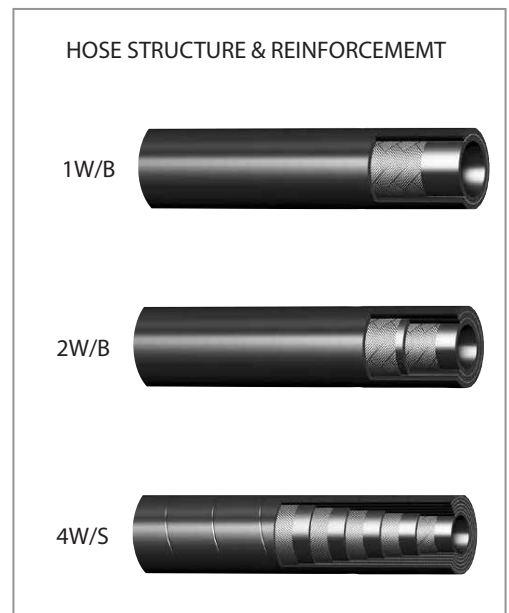

Size	Reinforcement	Inner Diameter mm	Outer Diameter mm	Max Working Pressure MPa	Min. Burst Pressure MPa	Min. Bend Radius mm	Weight g/m
6	1W/B	6.3	13.2	21.0	84.0	60	230
9	2W/B	9.5	17.3	21.0	84.0	80	475
12	2W/B	12.7	21.0	21.0	84.0	90	595
15	2W/B	15.9	25.0	21.0	84.0	120	715
19	2W/B	19.0	28.4	21.0	84.0	140	885
25	2W/B	25.4	34.9	21.0	84.0	180	1245
65	4W/S	63.5	82.2	21.0	84.0	670	6470

SIZE	A	B	C	D	E	H1	H2	L	Thread	Weight (g)
6	8.5	16.0	6	4.2	9.5	19	19	51	1/4	70
9	9.5	19.0	6	7.0	13.0	22	22	54	3/8	100
12	11.0	21.5	8	9.5	16.0	27	27	62	1/2	170
15	12.5	23.0	10	16.0	22.0	36	30	69	3/4	250
19	12.5	23.0	10	16.1	22.0	36	30	72	3/4	270
25	12.5	25.5	12	21.8	28.0	41	36	89	1	370

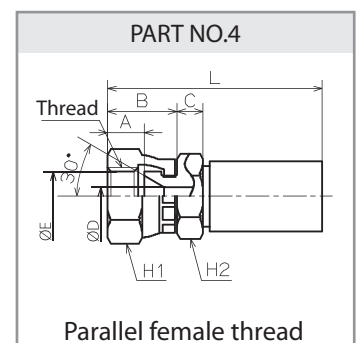

SIZE	A	B	C	D	E	H1	H2	L	Thread	Weight (g)
6	5.5	16.0	6	4.2	7.5	19	19	51	1/4	70
9	6.5	19.0	6	7.0	10.0	22	22	54	3/8	100
12	8.5	21.5	8	9.5	13.0	27	27	62	1/2	170
15	9.0	23.0	10	16.0	19.0	36	30	69	3/4	250
19	9.0	23.0	10	16.1	19.0	36	30	72	3/4	270
25	9.5	25.5	12	21.8	24.0	41	36	89	1	370

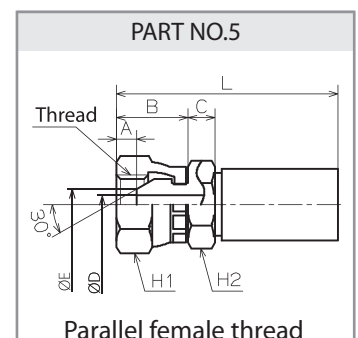

IBG280

HOSE STRUCTURE

- INNER COVER : OIL RESISTANT SYNTHETIC RUBBER
- REINFORCEMENT : STEEL WIRE
- OUTER COVER : OIL & OZONE RESISTANT SYNTHETIC RUBBER

- RECOMMENDED FLUIDS : MINERAL SYNTHETIC OIL
- OPERATING TEMPERATURE : -40°C ~ +100°C (-40°F ~ +212°F)



Size	Reinforcement	Inner Diameter mm	Outer Diameter mm	Max Working Pressure MPa	Min. Burst Pressure MPa	Min. Bend Radius mm	Weight g/m
6	2W/B	6.3	14.0	28.0	112.0	70	320
9	2W/B	9.5	17.3	28.0	112.0	80	475
12	2W/B	12.7	21.0	28.0	112.0	90	595

SIZE	A	B	C	D	E	H1	H2	L	Thread	Weight (g)
6	8.5	16.0	6	4.2	9.5	19	17	51	1/4	60
9	9.5	19.0	6	7.0	13.0	22	22	54	3/8	100
12	11.0	21.5	8	9.5	16.0	27	27	62	1/2	170

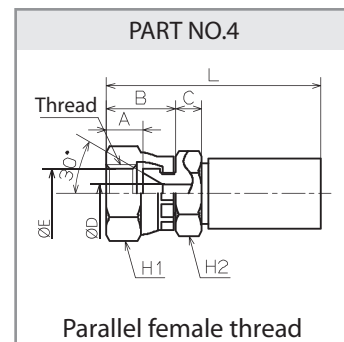

SIZE	A	B	C	D	E	H1	H2	L	Thread	Weight (g)
6	5.5	16.0	6	4.2	7.5	19	17	51	1/4	60
9	6.5	19.0	6	7.0	10.0	22	22	54	3/8	100
12	8.5	21.5	8	9.5	13.0	27	27	62	1/2	170

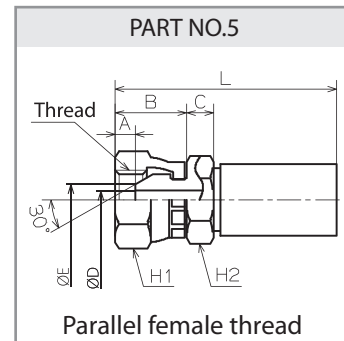

IBG320

HOSE STRUCTURE

- INNER COVER : OIL RESISTANT SYNTHETIC RUBBER
- REINFORCEMENT : STEEL WIRE
- OUTER COVER : OIL & OZONE RESISTANT SYNTHETIC RUBBER

RECOMMENDED FLUIDS OPERATING TEMPERATURE

MINERAL SYNTHETIC OIL -40°C ~ +100°C (-40°F ~ +212°F)



Size	Reinforcement	Inner Diameter mm	Outer Diameter mm	Max Working Pressure MPa	Min. Burst Pressure MPa	Min. Bend Radius mm	Weight g/m
6	2W/B	6.3	14.0	32.0	128.0	75	330
9	2W/B	9.5	17.7	32.0	128.0	105	495

SIZE	A	B	C	D	E	H1	H2	L	Thread	Weight (g)
6	8.5	16.0	6	4.2	9.5	19	17	51	1/4	60
9	9.5	19.0	6	7.0	13.0	22	22	54	3/8	100

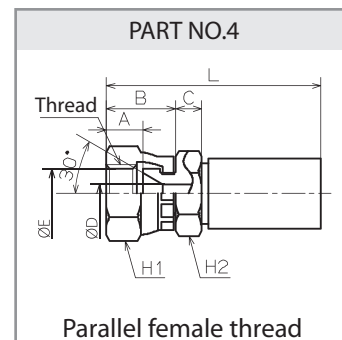

SIZE	A	B	C	D	E	H1	H2	L	Thread	Weight (g)
6	5.5	16.0	6	4.2	7.5	19	17	51	1/4	60
9	6.5	19.0	6	7.0	10.0	22	22	54	3/8	100

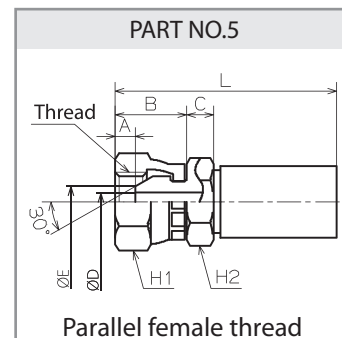

IBG350

HOSE STRUCTURE

- INNER COVER : OIL RESISTANT SYNTHETIC RUBBER
- REINFORCEMENT : STEEL WIRE
- OUTER COVER : OIL & OZONE RESISTANT SYNTHETIC RUBBER

RECOMMENDED FLUIDS OPERATING TEMPERATURE
 MINERAL SYNTHETIC OIL -40°C ~ +100°C (-40°F ~ +212°F)

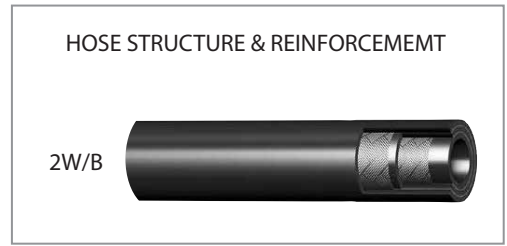

Size	Reinforcement	Inner Diameter mm	Outer Diameter mm	Max Working Pressure MPa	Min. Burst Pressure MPa	Min. Bend Radius mm	Weight g/m
6	2W/B	6.3	14.0	35.0	140.0	80	340
9	2W/B	9.5	17.7	35.0	140.0	110	495

SIZE	A	B	C	D	E	H1	H2	L	Thread	Weight (g)
6	8.5	16.0	6	4.2	9.5	19	17	51	1/4	60
9	9.5	19.0	6	7.0	13.0	22	22	54	3/8	100

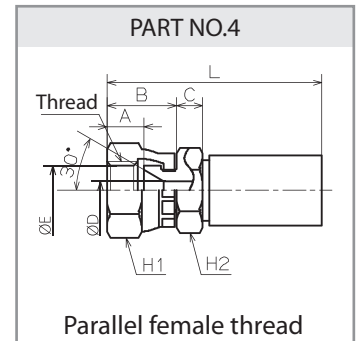

SIZE	A	B	C	D	E	H1	H2	L	Thread	Weight (g)
6	5.5	16.0	6	4.2	7.5	19	17	51	1/4	60
9	6.5	19.0	6	7.0	10.0	22	22	54	3/8	100

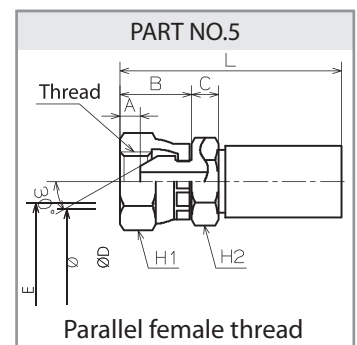

HOSE ADAPTER

There is a lineup of various hose joints that can reduce pressure loss, noise, vibration, and contamination.

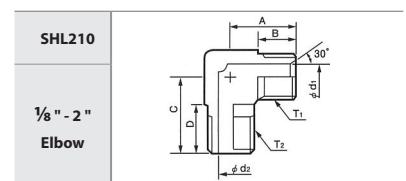
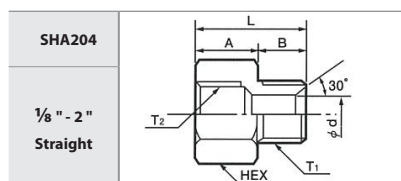
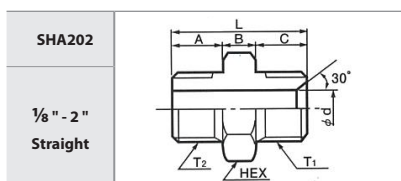
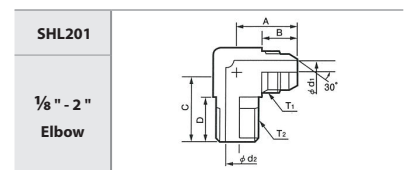
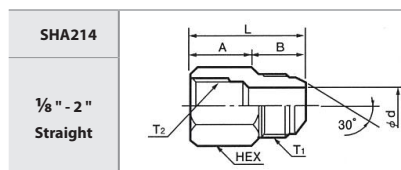
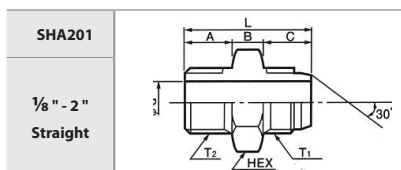



FITTINGS FOR HYDRAULIC APPLICATIONS

CLEAN PIPING FITTING	67
GENERAL PIPING FITTING & VALVES	68
HOSE ADAPTER	69



HYDRAULIC COUPLING

TSP CUPLA	70
SP CUPLA TYPE A	71
ZEROSPILL CUPLA	71
HSP CUPLA	72
210 CUPLA	72
280 CUPLA	73
350 CUPLA	73
FLAT FACE CUPLA F35	74
FLAT FACE CUPLA FF	74
450B CUPLA	75
700R CUPLA	75
MULTI CUPLA MAS / MAT TYPE	76
PURGE ADAPTER	77
HYDRAULIC MAINTENANCE SERVICE	78

CLEAN PIPING FITTING

Double Ferrule Type Tube Fitting

Mechanical fittings with two ferrules



- By simply tightening the nut, the back ferrule holds the tube and the front ferrule seals the fluid. Wetted parts are all made up of the same material, which means various fluids over a wide temperature range can be firmly sealed.
- *Stainless products are RoHS compliant.



Fitting for Plastic Tubes

Fitting developed for connecting plastic tubes



- Since it has only two components (main body and the nut) and can be tightened by turning the nut fully, anyone can ensure "easy and secure" connection of plastic tubes.



Fitting for Vinyl Hoses

Fitting developed for soft vinyl chloride hoses



- With a structure in which the hose inserted into the insert is pushed down by the sleeve through nut rotation, it enhances reliability against water leakage and hose pull-out.



GENERAL PIPING FITTING & VALVES

Bite Type Tube Fitting

Weld-less high-pressure fitting for hydraulic application



- This fitting eliminates the need for threading, welding, flaring, or brazing, and supports tube bending.



Swivel Joint

Compact and low-torque type swivel joint for hydraulic application



- Effective as a measure against twisting of hydraulic hoses, it has increased its durability.



High-pressure Threaded Socket-weld Fitting

Fitting used for medium to high pressure piping for hydraulic application



- It supports schedule pipes.



HOSE ADAPTER

There is a lineup of various hose joints that can reduce pressure loss, noise, vibration, and contamination.

Body material	Plated steel	
Fluid type	Hydraulic	
Model code	NNT	NHA : Smooth Flow Adapter
		NHL : Smooth Flow Elbow
	SH*	SHA : Existing Adapter
		SHL : Existing Elbow



<p>SHA201 NHA201</p>	<p>SHA202 NHA202</p>	<p>SHA203</p>	<p>SHA204</p>	<p>SHA205</p>	
<p>SHA206</p>	<p>SHA207</p>	<p>SHA208 NHA208</p>	<p>SHA209</p>	<p>SHA213</p>	
<p>SHA214</p>	<p>SHA215 NHA215</p>	<p>SHA216</p>	<p>SHA217</p>	<p>SHA230</p>	
<p>SHL201 NHL201</p>	<p>SHL202</p>	<p>SHL203</p>	<p>SHL204 SHL220 NHL204</p>	<p>SHL205 NHL205</p>	
<p>SHL210 NHL210</p>	<p>SHL211 NHL211</p>	<p>SHL212 NHL212</p>	<p>SHL213 SHL219</p>	<p>SHL214 SHL221</p>	
<p>SHL216</p>	<p>SHL217</p>	<p>SMS1</p>	<p>SMS2</p>	<p>SMS3</p>	<p>SMS4</p>

TSP CUPLA

Working pressure 1.5 to 7.5 MPa (15 to 76 kgf/cm ²)	Valve structure Straight through	Applicable fluids						
		Water	Hydraulic oil	Chemicals	Air	Gas	Steam	

Note: Depending on the temperature of steam / hot water the heat may damage seal materials.



- Valveless construction drastically saves pressure loss and achieves high flow rate.
- Suitable for high viscosity fluids (such as grease).
- Available in various standard body materials, sizes and end configurations to cope with diversified applications and operating situations.
- No hose clamp required! Simple and secure connection to braided hose.

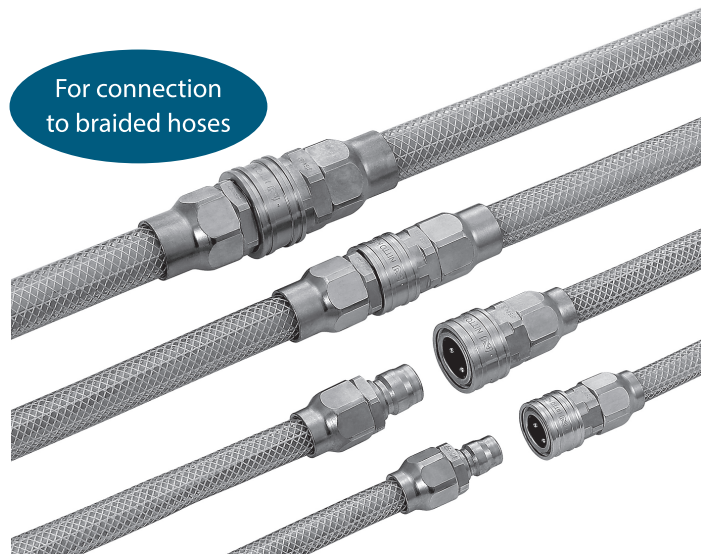

HYDRAULIC COUPLING



Specification

Body material		Brass				Stainless steel (SUS304), Steel (Nickel plated)			
		1/8", 1/4", 3/8", 1/2"	3/4", 1"	1 1/4", 1 1/2"	2"	1/8", 1/4", 3/8", 1/2"	3/4", 1"	1 1/4", 1 1/2"	2"
Working pressure	MPa	5.0	3.0	2.0	1.5	7.5	4.5	3.0	2.0
	kgf/cm ²	51	31	20	15	76	46	31	20
	bar	50	30	20	15	75	45	30	20
	PSI	725	435	290	218	1090	653	435	290
Seal material* ¹ Working temperature range* ²		Seal material		Mark		Working temperature range		Remarks	
		Nitrile rubber		NBR		-20°C to +80°C		Standard material	
		Fluoro rubber		FKM		-20°C to +180°C			
		Ethylene - propylene rubber		EPDM		-40°C to +150°C			

- SUS316 is available as option.

- Maximum working pressure and working temperature range of TSP CUPLA for braided hoses depend upon the specification of braided hoses to be used.

*1 : Seal material available for braided hoses is nitrile rubber only.

*1 : Seal material available for steel body is nitrile rubber only.

*2 : The operable temperature range depends on the operating conditions.

SP CUPLA TYPE A

Working pressure 1.5 to 7.5 1.5 to 7.5 MPa (15 to 75 kgf/cm ²)	Valve structure Two-way shut-off	Applicable fluids Water Hydraulic oil Chemicals Air Gas Steam	Note: Depending on the temperature of steam / hot water the heat may damage seal materials.
--	--	--	---



- For medium pressure applications, with automatic shut-off valves in both socket and plug.
- Available in various standard body materials, sizes and end configurations to cope with diversified applications and operating situations.

Specification

Body material		Brass				Stainless steel (SUS304), Steel (Nickel plated)			
Size (Thread)		1/8", 1/4", 3/8"	1/2", 3/4", 1"	1 1/4", 1 1/2"	2"	1/8", 1/4", 3/8"	1/2", 3/4", 1"	1 1/4", 1 1/2"	2"
Working pressure	MPa	5.0	3.0	2.0	1.5	7.5	4.5	3.0	2.0
	kgf/cm ²	51	31	20	15	76	46	31	20
	bar	50	30	20	15	75	45	30	20
	PSI	725	435	290	218	1090	653	435	290
Seal material *1 Working temperature range *2	Seal material		Mark		Working temperature range		Remarks		
	Nitrile rubber		NBR		-20°C to +80°C		Standard material		
	Fluoro rubber		FKM		-20°C to +180°C				
	Ethylene-propylene rubber		EPDM		-40°C to +150°C				

*1: Plugs with male thread with nitrile rubber or ethylene-propylene rubber are made-to-order items.

*1: Seal material available for steel body is nitrile and fluoro rubber.

*2: The operable temperature range depends on the operating conditions.

ZEROSPILL CUPLA

Working pressure 3.5 3.5 MPa (35 kgf/cm ²)	Valve structure Two-way shut-off (Spill Reduction)	Applicable fluids Water Hydraulic oil Chemicals Air Gas
--	---	---



- New valve design offer smooth zero-friction movement.
- Push to connect design.
- The variety of body materials, sizes and end configurations has been standardized to comply with wide range of application.
- Automatic shut-off valves in both socket and plug prevent fluid spill out on disconnection.

Specification

Body material		Brass		Stainless steel (SUS 304)				
Size (Thread)		1/4", 3/8", 1/2", 3/4", 1"						
Pressure unit		MPa	kgf/cm ²	bar	PSI			
Working pressure		3.5	36	36	508			
Seal material Working temperature range *1	Seal material		Mark		Working temperature range		Remarks	
	Nitrile rubber		NBR		-20°C to +80°C		Standard material	
	Fluoro rubber		FKM		-20°C to +180°C		Standard material	
	Ethylene-propylene rubber		EPDM		-40°C to +150°C		Standard material	

*1: The operable temperature range depends on the operating conditions.

HSP CUPLA

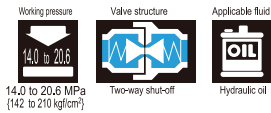

- Quenched special steel body! Powerful impact resistance, especially against impulses.
- Automatic shut-off valves in both socket and plug prevent fluid spill out on disconnection. Easy to handle.
- In addition to convention female thread type, male thread type (male tapered thread, male parallel thread with 30° flare, and male parallel thread with 30° cone-seat) are available. Male thread type are designed especially for direct connection to hydraulic power units effectively.
- Male parallel thread type complies with both metal seal and O-ring seal. (In case of O-ring seal, O-rings available in the market can be used.)
- Optional HSP-DC Cuplas are available for die-casting machine applications with severe pressure variation.



HYDRAULIC COUPLING

Specification

Body material	Special steel (Nickel plated)			
Size (Thread)	1/4", 3/8", 1/2", 3/4", 1"		1 1/4", 1 1/2"	
Working pressure	MPa	20.6	18.0	14.0
	kgf/cm²	210	183	142
	bar	206	180	140
	PSI	2990	2610	2030
Seal material Working temperature range *1	Seal material	Mark	Working temperature range	Remarks
	Nitrile rubber	NBR	-20°C to +80°C	Standard material
	Fluoro rubber	FKM	-20°C to +180°C	Available on request

*1: The operable temperature range depends on the operating conditions.

210 CUPLA

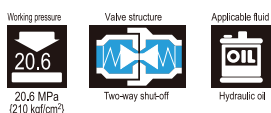

- Standard hydraulic cuplas for general purposes with a working pressure up to 20.6 MPa. Low pressure loss, suitable for hydraulic equipment.
- Structure is designed to reduce pressure loss to the lowest, and is best for hydraulic applications that need big flow rates.
- Both socket and plug have built-in automatic shut-off valves that prevent fluid outflow when disconnected. Easy to handle.



Specification

Body material	Special steel (Nickel plated)			
Size (Thread)	1/4", 3/8", 1/2", 3/4", 1"			
Pressure unit	MPa	kgf/cm²	bar	PSI
Working pressure	20.6	210	206	2990
Seal material Working temperature range *1	Seal material	Mark	Working temperature range	Remarks
	Nitrile rubber	NBR	-20°C to +80°C	Standard material
	Fluoro rubber	FKM	-20°C to +180°C	Available on request

*1: The operable temperature range depends on the operating conditions.

NITTO KOHKI

280 CUPLA



- General purpose hydraulic with the working pressure up to 27.5 to 31.5 MPa {281 to 321 kgf/cm²}
- Structure keeps pressure loss extremely low, particularly ideal for hydraulic applications requiring high flow rates.
- Both socket and plug have built-in automatic shut-off valves to prevent fluid spill out when disconnected. Easy to handle.
- Special steel body material is adopted for its excellent strength and additional quenching treatment is done to withstand hydro pressure impacts.



HYDRAULIC COUPLING

Specification

Body material		Special steel (Bright chromate conversion coating : silver color)			
Size (Thread)		1/4", 3/8"		1/2", 3/4", 1"	
Working pressure	MPa	31.5		27.5	
	kgf/cm²	321		281	
	bar	315		275	
	PSI	4570		3990	
Seal material	Seal material	Mark	Working temperature range	Remarks	
Working temperature range *1	Nitrile rubber	NBR	-20°C to +80°C	Standard material	

*1: The operable temperature range depends on the operating conditions.

350 CUPLA

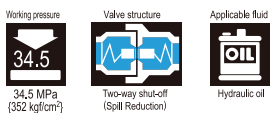

- Their "airless valve shut-off design" greatly reduces air admixture! Ideal for hydraulic lines with larger pressure fluctuations.
- Sleeve stopper mechanism can be engaged by rotating sleeve after connection.
- Both socket and plug have built-in automatic shut-off valves to prevent fluid spill out when disconnected. Easy to handle.



Specification

Body material		Special steel (Nickel plated)			
Size (Thread)		1/4", 3/8", 1/2", 3/4", 1 1/4", 1 1/2"			
Pressure unit	MPa	kgf/cm²	bar	PSI	
Working pressure	34.5	352	345	5000	
Seal material	Seal material	Mark	Working temperature range	Remarks	
Working temperature range *1	Fluoro rubber	FKM	-20°C to +180°C	Standard material	

*1: The operable temperature range depends on the operating conditions.

FLAT FACE CUPLA F35

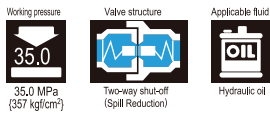

- Flat contact face design minimizes air admixture during connection to keep the possible malfunction of equipment caused by the air bubbles in the hydraulic line at minimum level.
- Push-to-connect operation.
- Sleeve stopper mechanism is engaged by rotating sleeve after connection. It prevents accidental disconnection even when vibration or impact is applied to the cupla.
- The special design reduces pressure loss considerably, and especially suited to hydraulic applications in which big flow is needed.
- Both socket and plug have built-in automatic shut-off valves that prevent fluid spill out on disconnection.



Specification

Body material	Special steel (Nickel plated)			
Size (Thread)	1/4", 3/8", 1/2", 3/4", 1"			
Pressure unit	MPa	kgf/cm²	bar	PSI
Working pressure	35.0	357	350	5080
Seal material	Seal material	Mark	Working temperature range	Remarks
Working temperature range *1	Fluoro rubber	FKM	-20°C to +180°C	Standard material

*1: The operable temperature range depends on the operating conditions.

FLAT FACE CUPLA FF

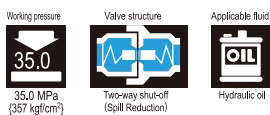

- "Airless valve shut-off" design minimizes spillage volume on disconnection and admixture volume of air on connection.
- Best suited for hydraulic lines with drastic high-pressure pulsation such as in die-casting machines.
- Sleeve stopper design prevention accidental disconnection under vibration or impacts enhances workability and safety.
- Sizes and Rc 3/8, Rc 1/2, Rc 3/4, and Rc 1.

*Only the same size of socket and plug can be connected.



Specification

Body material	Special steel (Nickel plated)			
Size (Thread)	3/8", 1/2", 3/4", 1"			
Pressure unit	MPa	kgf/cm²	bar	PSI
Working pressure	35.0	357	350	5080
Seal material	Seal material	Mark	Working temperature range	Remarks
Working temperature range *1	Nitrile rubber	NBR	-20°C to +80°C	Standard material

*1: The operable temperature range depends on the operating conditions.

450B CUPLA

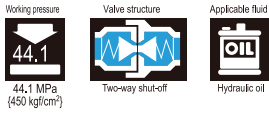

- Coupla for higher working pressure up to 44.1 MPa {450 kgf/cm²}.
- Sleeve stopper mechanism can be engaged by rotating sleeve after connection.
- Both socket and plug have metal-touch automatic shut-off valves that prevent fluid spill out on disconnection.



Specification

Body material	Special steel (Nickel plated)			
Size (Thread)	3/8"			
Pressure unit	MPa	kgf/cm²	bar	PSI
Working pressure	44.1	450	441	6400
Seal material Working temperature range *1	Seal material	Mark	Working temperature range	Remarks
	Nitrile rubber	NBR	-20°C to +80°C	Standard material
	Fluoro rubber	FKM	-20°C to +180°C	Made-to-order item
Stand-alone leakage rate on either socket or plug	0.1 mL/min at 0.3 MPa {3 kgf/cm ² }			

*1: The operable temperature range depends on the operating conditions.

700R CUPLA

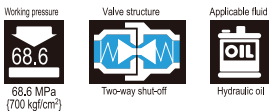

- High pressure coupla for working pressures up to 68.6 MPa
- Metal-touch valves use no rubber seal, and thus ensure excellent durability.
- Both socket and plug have metal-touch automatic shut-off valves that prevent fluid spill out on disconnection.



Specification

Body material	Special steel (Nickel plated)			
Size (Thread)	3/8", 1/2"			
Pressure unit	MPa	kgf/cm²	bar	PSI
Working pressure	68.6	700	686	9,950
Seal material Working temperature range *1	Seal material	Mark	Working temperature range	Remarks
	Nitrile rubber	NBR	-20°C to +80°C	Standard material
	Fluoro rubber	FKM	-20°C to +180°C	Made-to-order item
Stand-alone leakage rate on either socket or plug	For 700R-3SP, 0.05 mL/min at 0.2 MPa {2 kgf/cm ² } For 700R-4SP, 0.05 mL/min at 0.3 MPa {3 kgf/cm ² }			

- Do not use in an environment where there is impulse pressure.

*1: The operable temperature range depends on the operating conditions.

MULTI CUPLA MAS / MAT TYPE

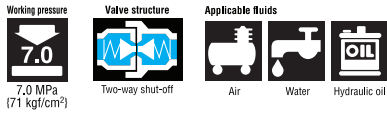

- Ideal for automated hydraulic or pneumatic cylinder operated systems that need to connect and disconnect several lines simultaneously.
- Automatic shut-off valves in both sockets and plugs ensure no outflow of fluid on disconnection.
- Body materials other than stainless steel are available, which can be ordered with or without valves (made-to-order products).
- Snap ring and screw thread-in types to mount on the base plate are standardized.
- MAS type can accept axial eccentricity between socket and plug. The allowance of eccentricity is within the radius range of 0.3 mm.

*CUPLA connection or disconnection with fluid under dynamic pressure cannot be made.

Specification

Body material		Stainless steel (Nickel-plated)		
Working pressure	MPa	7.0		
	kgf/cm²	71		
	bar	70		
	PSI	1020		
Seal material		Seal material	Mark	Working temperature range
Working temperature range*1		Fluoro rubber	FKM	-20°C to +180°C

*1 : The operable temperature range depends on the operating conditions.

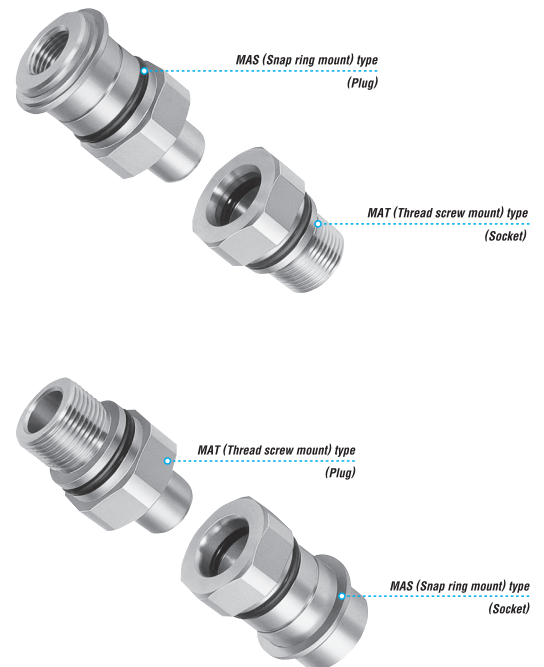

Application Example

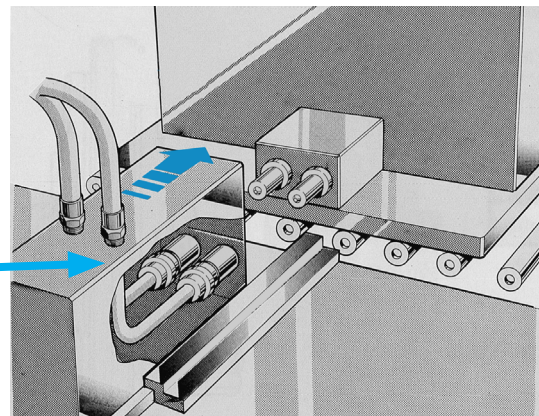
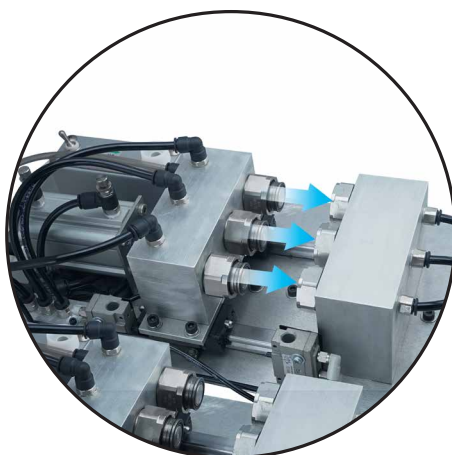

Oil and air circuits single action connect/disconnect for automated mold replacement

PURGE ADAPTER

- Can be attached to hydraulic lines to purge residual pressure effectively.

Couplings and hoses are not included.
Please purchase them separately.



HYDRAULIC COUPLING

NITTO KOHKI

Specification

Model	PAD-2	PAD-3FM	PAD-4FM	PAD-6FM	PAD-8FM
Body material	Steel (Nickel plated)				
Applicable	R 1/4	R 3/8 x Rc 3/8	R 1/2 x Rc 1/2	R 3/4 x Rc 3/4	R 1 x Rc 1
Pressure unit	MPa	kgf/cm ²	bar	PSI	
Working pressure	35.0	357	350	5080	
Drain outlet port	For 8 mm OD tube	Application : Rc 1/8 (Max. Tightening Torque : 5 Nm)			
Applicable fluids	Hydraulic oil				
Seal material Working temperature range *1	Seal material	Mark	Working temperature range	Remarks	
	Nitrile rubber	NBR	-5°C to +80°C	Standard material	

*1 : The operable temperature range depends on the operating conditions.

HYDRAULIC MAINTENANCE SERVICE

บริการให้คำปรึกษาและบำรุงรักษา ปั๊มไฮดรอลิกและเครื่องควบคุมอุณหภูมิน้ำมันไฮดรอลิก

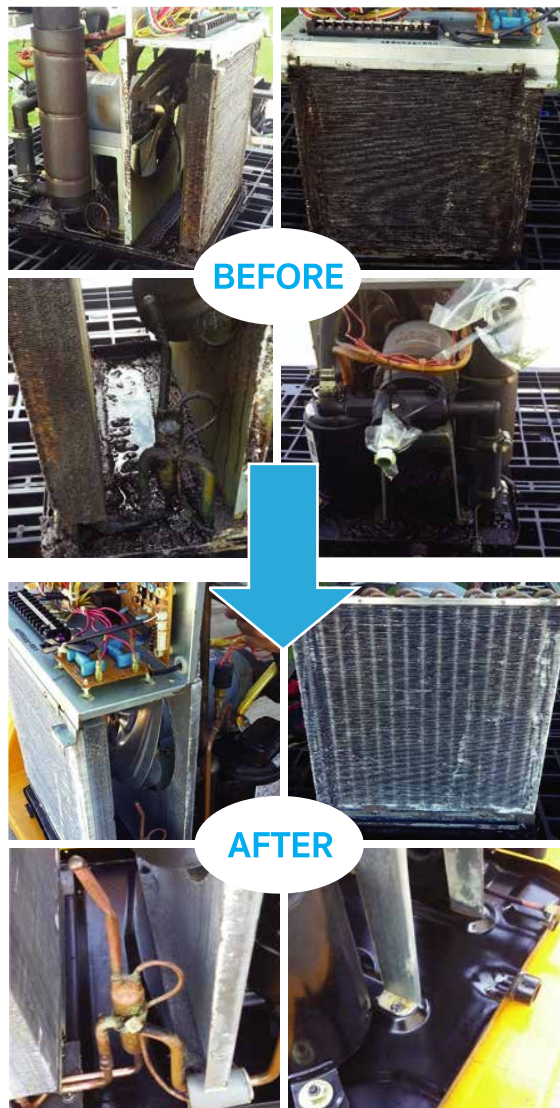

Checking Service

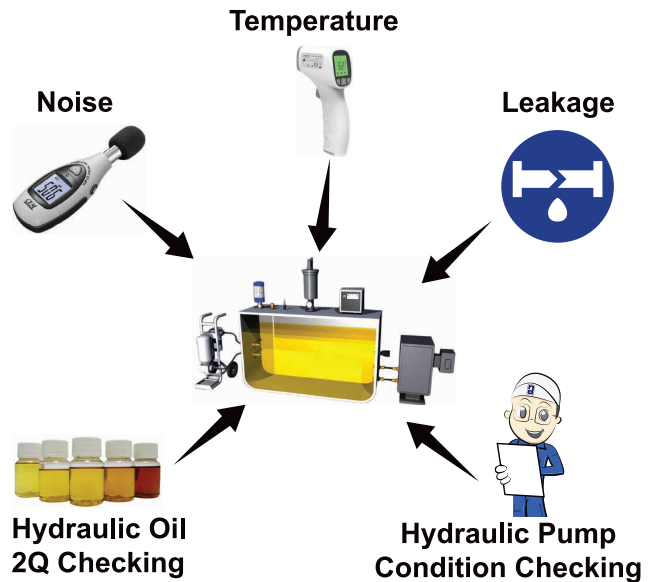

HYDRAULIC MAINTENANCE SERVICE

Cleaning Process

ตามมาตรฐาน DAIKIN Hydraulic Division

1. ตรวจสอบเช็คสภาพเครื่อง และบันทึกค่าลงแบบฟอร์มก่อนการล้าง
2. จัดเตรียม ถอด ห่อหุ้มชิ้นส่วนสำคัญของตัวเครื่องก่อนการล้าง
3. ฉีดล้าง ทำความสะอาด และเป่าแห้งทุกชิ้นส่วนตามขั้นตอน
4. ประกอบ ทดสอบ และบันทึกค่าลงแบบฟอร์มหลังการล้าง เพื่อส่งคืนลูกค้าต่อไป

SERVICE PROCESS

1. ตรวจสอบการทำงานของเครื่องอย่างละเอียด
Check units running condition in detail.
2. ตรวจสอบสัญญาณเตือนต่างๆของตัวเครื่อง
Check alarm history of the units.
3. ทำการบันทึกผลการตรวจสอบ และวิเคราะห์การทำงานของเครื่อง
Record and analyze the condition of the units.
4. ทำการแจ้งลูกค้าถึงอาการของตัวเครื่องและขอการตัดสินใจในการซ่อมหรือรับบริการอื่นๆ
Report to customer on the units condition and consult on the next process.
5. ทำความสะอาดเครื่อง ซึ่งช่วยปรับปรุงประสิทธิภาพการทำงานของเครื่อง
Clean the units to improve capacity of the equipment.
6. หากพบอะไหล่ชำรุดจะดำเนินการเปลี่ยนอะไหล่แท้ของไดकिनเท่านั้น
If damaged parts are found, the broken parts will be replaced only with genuine Daikin spare parts.

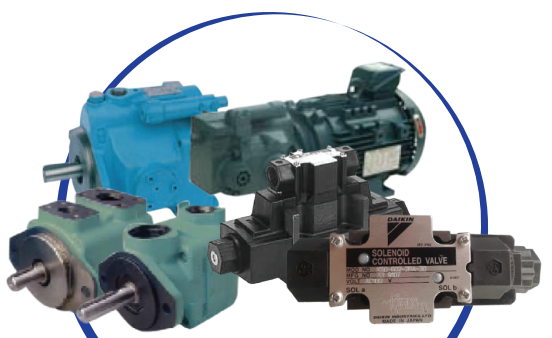

Genuine Spare Parts



บริษัท นานตีอินเตอร์เทรด จำกัด
NANDEE INTER-TRADE CO., LTD.

314, 316, 318, 320, 322 ซอยจันทน์ 32 ถนนจันทน์ แขวงทุ่งวัดดอน เขตสาทร กทม. 10120

-  : 0-2675-8239
-  : @nandeeintertrade
-  : nandeeintertrade
-  : www.nandee.co.th
-  : marketing@nandee.co.th
sales_y@nandee.co.th