

# Ezi-SPEED<sup>®</sup>

# ST

## BLDC Motor Speed Control System

- AC Input (220V) BLDC Motor Speed Control System
- Compact · Light Weight · High Power · High Efficiency Brushless Motor
- Wide Speed Control Range (50~4000r/min)
- Stable Speed Control by Vector Control (Speed Regulation within  $\pm 0.2\%$ )
- Easy Connection, Easy Operation
- Various Product Line-Up (30, 60, 120, 200, 400W)



CE

**FASTECH**

*Fast, Accurate, Smooth Motion*



*Fast, Accurate, Smooth Motion*

**Ezi-SPEED<sup>®</sup> ST**

**BLDC Motor Speed Control System**

# 1 BLDC Motor Unit

A typical DC motor is rotated using a brush and rectifier. Therefore, maintenance is required on a regular basis. On the other hand, BLDC (Brushless DC) motors do not use mechanical contacts and rotate through a driving circuit made of semiconductors, so they have a long lifespan and excellent maintainability. A permanent magnet is built into the rotor to increase efficiency, and the torque characteristics are maintained constant in all speed ranges by automatically controlling the motor current. In addition, since feedback control is performed using Hall IC, the speed can be accurately controlled according to the command from low speed to high speed.

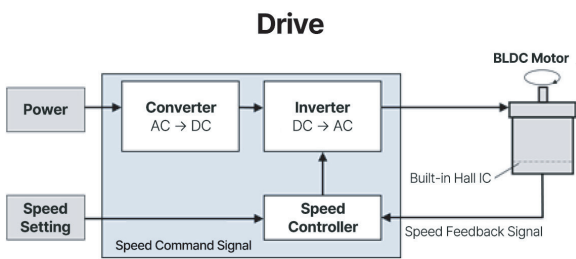

< Control Block Diagram >

The BLDC motor has a constant torque from low speed to rated rotational speed. Therefore, it rotates at a stable speed no matter how the load changes in size. BLDC motor has continuous duty region (①) and limited duty region (②). Limited region can be used as the acceleration torque when starting the inertial stuff. However, in this region, if it's used for more than 40 seconds, overload protection is protected and the motor stops.

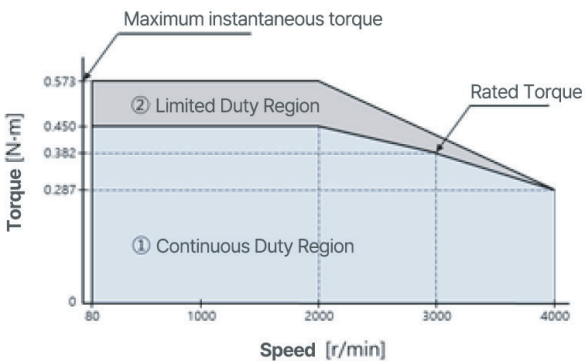

< Example of torque characteristics according to speed of BLDC motor >

# 2 High Precision Speed Control (Speed Regulation ±0.2%)

Ezi-SPEED compares the setting speed with the speed feedback signals from the motor at all time, and adjusts the motor current using vector control algorithm. So, even if the load changes, stable rotation is maintained from low speed to high speed. Inverter controlled AC induction motor does not perform feedback control, so the speed will be reduced significantly when load increases.

Ezi-SPEED is recommended for applications that require stable speed.

■ Speed measuring value

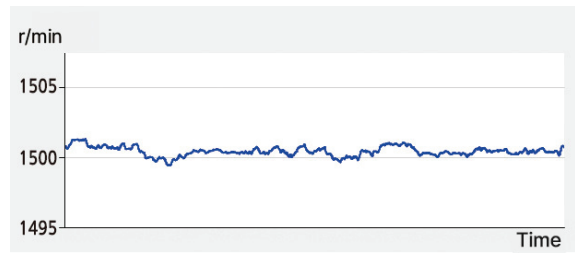

Ezi-SPEED 120W

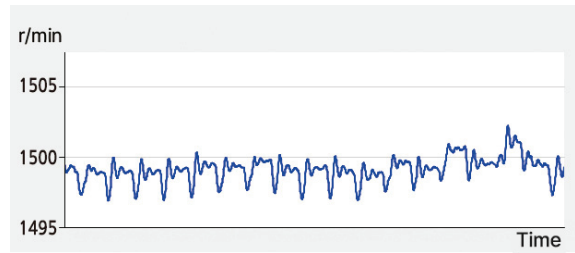

Inverter + AC induction motor 100W

\* Load factor : 95%      \* Setting speed : 1,500r/min  
\* Resolution of external encoder for measuring velocity ripple : 32,000P/R

### 3 Wide Speed Control Range

(Speed Ratio: 1:80)

Ezi-SPEED has wide speed control range compared to AC induction motor with inverter. Because torque is not restricted at low speed, Ezi-SPEED is recommended for application that requires stable torque over from low to high speed.

Product	Speed Control Range [r/min]	Speed Ratio
Ezi-SPEED	50~4,000	1:80
Inverter + AC induction motor	200~2,400	1:12

\* Speed range of Inverter + AC induction motor varies depending on model type.

### 4 Compact / Light Weight / High Power / High Efficiency

Unlike AC induction motors, BLDC motors use permanent magnets in the rotor so that it could prevent secondary loss from rotor.

Therefore, BLDC motors has higher efficiency than inverter controlled AC induction motor so that customers can save energy.

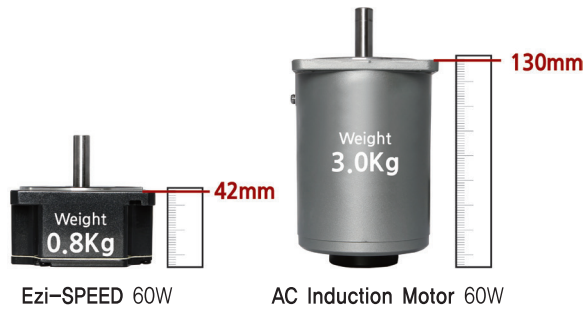

- Comparison of motor temperature after 4 hours continuous operation when load factor is 100% and Setting speed is 1,500r/min.

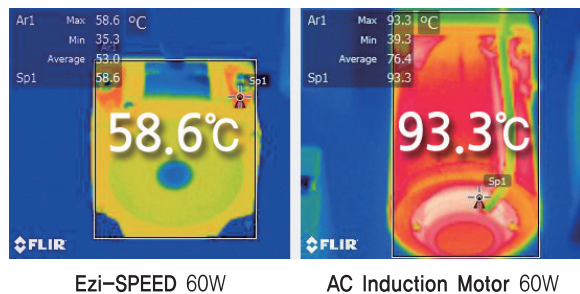

### 5 Easy Wiring

The motor and sensor connector can be easily connected to drive. There is no need for soldering or special tools when connecting the power and I/O cables. For power connector, just insert the lead wire and fix using screw driver. For I/O connector, just insert the lead wire while pushing the orange button.

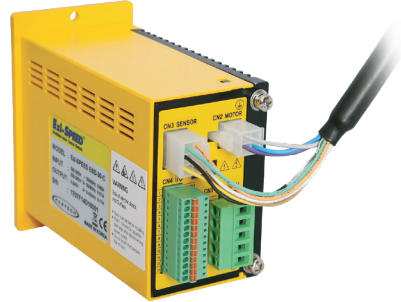

Motor Connector Wiring

### 6 Easy to Use

(Front Panel)

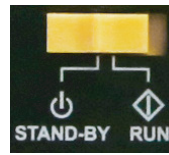

#### • Control of Operation and Stop

The motor starts when switch is in the "RUN" position, and stops after deceleration when it is moved to the "STAND-BY" position.



#### • Control of rotation direction

Changing the rotation direction during the operation.

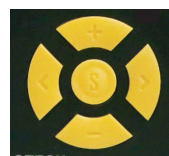

#### • Control of Speed

The speed control buttons allow you to use simple speed control and many functions.

Pushing button increases the speed and pushing button reduces the speed.

When the desired speed is reached, simply push the button to set the speed value.

### 7 Operation by External I/O

External I/O can control Start/Stop, Changing rotation direction and Multi speed operation.



Ezi-SPEED

I/O operation



PLC

## 8

## Display Load Factor and Actual Speed

Load factor is displayed as percentage like 100% for rated torque. User can check the load during operating the motor and can maintain the motor in optimal condition by checking load changes due to the secular change.

Also the actual speed can be displayed.  
(Motor speed, Gearbox speed, Linear speed)



Indication at load factor of 100%



Actual speed at setting speed of 1,500r/min

## 9

## 8-Speed Settings

8 steps speed operation can be done by setting No.0 ~ No.7 data using inputs P0, P1, P2. We can do this only with Ezi-SPEED without any extra controller.

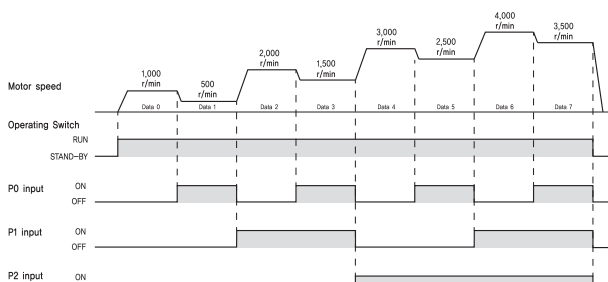

## 10

## Various Functions can be Set on the Drive

- Motor Start/Stop
- Setting the operation speed
- Changing the rotation direction
- Changing the indication
- Operation speed indication when the speed decreasing or increasing ratio is set
- Setting the acceleration/deceleration time
- Button operation lock
- Speed setting for 8-speed operation
- Speed limits setting
- Validating the external operation signals
- External I/O signal allocation
- Setting the overload alarm detection time

## 11

## Protection Function

- Ezi-SPEED detect abnormal situations like overload, over voltage etc. When this happens, the operation is stopped and alarm is displayed.
- A regenerative resistor can be used when the deceleration time is short or when the large inertia load is used. Also the protection function can be activated for the excessive external force acting on the motor shaft.

## ● Ezi-SPEED Part Numbering

### Ezi-SPEED-60-H-30-C-R5-P

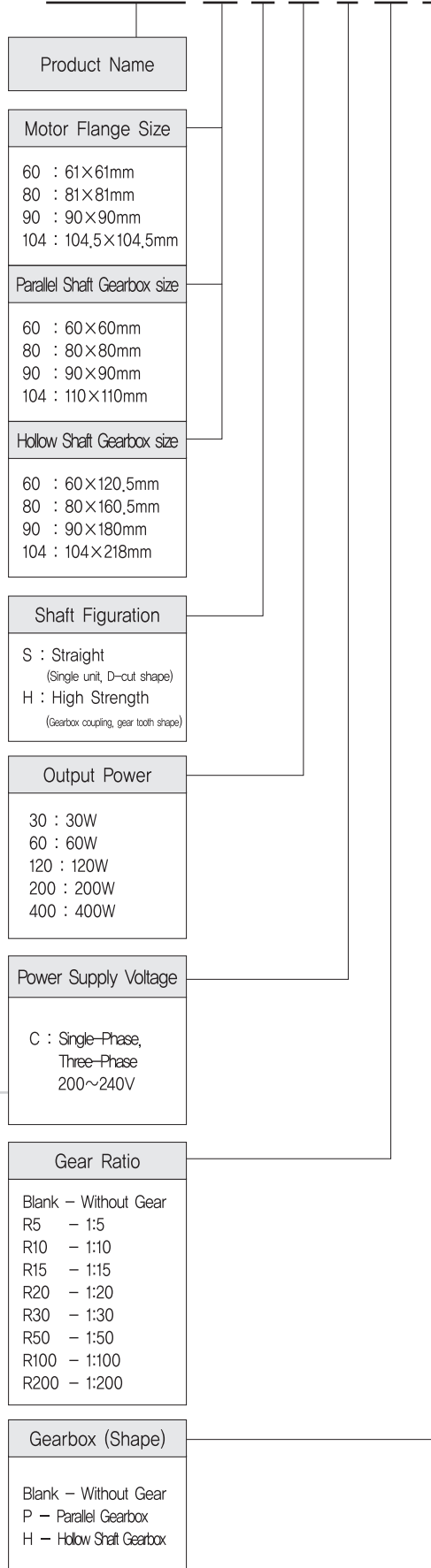

FASTECH Ezi-SPEED

## ● Standard Combination

Output Power	Unit Part Number	Motor Model Number	Drive Model Number
30W	Ezi-SPEED-60-S-30-C	ESM-60-S-30	ESD-30-C
60W	Ezi-SPEED-80-S-60-C	ESM-80-S-60	ESD-60-C
120W	Ezi-SPEED-90-S-120-C	ESM-90-S-120	ESD-120-C
200W	Ezi-SPEED-104-S-200-C	ESM-104-S-200	ESD-200-C
400W	Ezi-SPEED-104-S-400-C	ESM-104-S-400	ESD-400-C

## ● Combination with Gearbox

Output Power	Unit Part Number	Motor Model Number	Drive Model Number	Gearbox Model Number	Gear Ratio
30W	Ezi-SPEED-60-H-30-C-R5-P	ESM-60-H-30	ESD-30-C	ESG-60-H-R5-P	1:5
	Ezi-SPEED-60-H-30-C-R5-H			ESG-60-H-R5-H	
	Ezi-SPEED-60-H-30-C-R10-P			ESG-60-H-R10-P	1:10
	Ezi-SPEED-60-H-30-C-R10-H			ESG-60-H-R10-H	
	Ezi-SPEED-60-H-30-C-R15-P			ESG-60-H-R15-P	1:15
	Ezi-SPEED-60-H-30-C-R15-H			ESG-60-H-R15-H	
	Ezi-SPEED-60-H-30-C-R20-P			ESG-60-H-R20-P	1:20
	Ezi-SPEED-60-H-30-C-R20-H			ESG-60-H-R20-H	
	Ezi-SPEED-60-H-30-C-R30-P			ESG-60-H-R30-P	1:30
	Ezi-SPEED-60-H-30-C-R30-H			ESG-60-H-R30-H	
	Ezi-SPEED-60-H-30-C-R50-P			ESG-60-H-R50-P	1:50
	Ezi-SPEED-60-H-30-C-R50-H			ESG-60-H-R50-H	
	Ezi-SPEED-60-H-30-C-R100-P			ESG-60-H-R100-P	1:100
	Ezi-SPEED-60-H-30-C-R100-H			ESG-60-H-R100-H	
	Ezi-SPEED-60-H-30-C-R200-P			ESG-60-H-R200-P	1:200
	Ezi-SPEED-60-H-30-C-R200-H			ESG-60-H-R200-H	

## ● Combination with Gearbox

Output Power	Unit Part Number	Motor Model Number	Drive Model Number	Gearbox Model Number	Gear Ratio			
60W	Ezi-SPEED-80-H-60-C-R5-P	ESM-80-H-60	ESD-60-C	ESG-80-H-R5-P	1:5			
	Ezi-SPEED-80-H-60-C-R5-H			ESG-80-H-R5-H				
	Ezi-SPEED-80-H-60-C-R10-P			ESG-80-H-R10-P	1:10			
	Ezi-SPEED-80-H-60-C-R10-H			ESG-80-H-R10-H				
	Ezi-SPEED-80-H-60-C-R15-P			ESG-80-H-R15-P	1:15			
	Ezi-SPEED-80-H-60-C-R15-H			ESG-80-H-R15-H				
	Ezi-SPEED-80-H-60-C-R20-P			ESG-80-H-R20-P	1:20			
	Ezi-SPEED-80-H-60-C-R20-H			ESG-80-H-R20-H				
	Ezi-SPEED-80-H-60-C-R30-P			ESG-80-H-R30-P	1:30			
	Ezi-SPEED-80-H-60-C-R30-H			ESG-80-H-R30-H				
	Ezi-SPEED-80-H-60-C-R50-P			ESG-80-H-R50-P	1:50			
	Ezi-SPEED-80-H-60-C-R50-H			ESG-80-H-R50-H				
	Ezi-SPEED-80-H-60-C-R100-P			ESG-80-H-R100-P	1:100			
	Ezi-SPEED-80-H-60-C-R100-H			ESG-80-H-R100-H				
	Ezi-SPEED-80-H-60-C-R200-P			ESG-80-H-R200-P	1:200			
	Ezi-SPEED-80-H-60-C-R200-H			ESG-80-H-R200-H				
	120W			Ezi-SPEED-90-H-120-C-R5-P	ESM-90-H-120	ESD-120-C	ESG-90-H-R5-P	1:5
				Ezi-SPEED-90-H-120-C-R5-H			ESG-90-H-R5-H	
				Ezi-SPEED-90-H-120-C-R10-P			ESG-90-H-R10-P	1:10
				Ezi-SPEED-90-H-120-C-R10-H			ESG-90-H-R10-H	
Ezi-SPEED-90-H-120-C-R15-P		ESG-90-H-R15-P	1:15					
Ezi-SPEED-90-H-120-C-R15-H		ESG-90-H-R15-H						
Ezi-SPEED-90-H-120-C-R20-P		ESG-90-H-R20-P	1:20					
Ezi-SPEED-90-H-120-C-R20-H		ESG-90-H-R20-H						
Ezi-SPEED-90-H-120-C-R30-P		ESG-90-H-R30-P	1:30					
Ezi-SPEED-90-H-120-C-R30-H		ESG-90-H-R30-H						
Ezi-SPEED-90-H-120-C-R50-P		ESG-90-H-R50-P	1:50					
Ezi-SPEED-90-H-120-C-R50-H		ESG-90-H-R50-H						
Ezi-SPEED-90-H-120-C-R100-P		ESG-90-H-R100-P	1:100					
Ezi-SPEED-90-H-120-C-R100-H		ESG-90-H-R100-H						
Ezi-SPEED-90-H-120-C-R200-P		ESG-90-H-R200-P	1:200					
Ezi-SPEED-90-H-120-C-R200-H		ESG-90-H-R200-H						

Output Power	Unit Part Number	Motor Model Number	Drive Model Number	Gearbox Model Number	Gear Ratio			
200W	Ezi-SPEED-104-H-200-C-R5-P	ESM-104-H-200	ESD-200-C	ESG-104-H-R5-P	1:5			
	Ezi-SPEED-104-H-200-C-R5-H			ESG-104-H-R5-H				
	Ezi-SPEED-104-H-200-C-R10-P			ESG-104-H-R10-P	1:10			
	Ezi-SPEED-104-H-200-C-R10-H			ESG-104-H-R10-H				
	Ezi-SPEED-104-H-200-C-R15-P			ESG-104-H-R15-P	1:15			
	Ezi-SPEED-104-H-200-C-R15-H			ESG-104-H-R15-H				
	Ezi-SPEED-104-H-200-C-R20-P			ESG-104-H-R20-P	1:20			
	Ezi-SPEED-104-H-200-C-R20-H			ESG-104-H-R20-H				
	Ezi-SPEED-104-H-200-C-R30-P			ESG-104-H-R30-P	1:30			
	Ezi-SPEED-104-H-200-C-R30-H			ESG-104-H-R30-H				
	Ezi-SPEED-104-H-200-C-R50-P			ESG-104-H-R50-P	1:50			
	Ezi-SPEED-104-H-200-C-R50-H			ESG-104-H-R50-H				
	Ezi-SPEED-104-H-200-C-R100-P			ESG-104-H-R100-P	1:100			
	Ezi-SPEED-104-H-200-C-R100-H			ESG-104-H-R100-H				
	Ezi-SPEED-104-H-200-C-R200-P			ESG-104-H-R200-P	1:200			
	Ezi-SPEED-104-H-200-C-R200-H			ESG-104-H-R200-H				
	400W			Ezi-SPEED-104-H-400-C-R5-P	ESM-104-H-400	ESD-400-C	ESG-104-H-R5-P	1:5
				Ezi-SPEED-104-H-400-C-R5-H			ESG-104-H-R5-H	
				Ezi-SPEED-104-H-400-C-R10-P			ESG-104-H-R10-P	1:10
				Ezi-SPEED-104-H-400-C-R10-H			ESG-104-H-R10-H	
Ezi-SPEED-104-H-400-C-R15-P		ESG-104-H-R15-P	1:15					
Ezi-SPEED-104-H-400-C-R15-H		ESG-104-H-R15-H						
Ezi-SPEED-104-H-400-C-R20-P		ESG-104-H-R20-P	1:20					
Ezi-SPEED-104-H-400-C-R20-H		ESG-104-H-R20-H						
Ezi-SPEED-104-H-400-C-R30-P		ESG-104-H-R30-P	1:30					
Ezi-SPEED-104-H-400-C-R30-H		ESG-104-H-R30-H						
Ezi-SPEED-104-H-400-C-R50-P		ESG-104-H-R50-P	1:50					
Ezi-SPEED-104-H-400-C-R50-H		ESG-104-H-R50-H						
Ezi-SPEED-104-H-400-C-R100-P		ESG-104-H-R100-P	1:100					
Ezi-SPEED-104-H-400-C-R100-H		ESG-104-H-R100-H						
Ezi-SPEED-104-H-400-C-R200-P		ESG-104-H-R200-P	1:200					
Ezi-SPEED-104-H-400-C-R200-H		ESG-104-H-R200-H						

## ● Specifications of Drive

Unit Part Number		ESD-30-C	ESD-60-C	ESD-120-C	ESD-200-C	ESD-400-C
Rated Output Power		30W	60W	120W	200W	400W
Power Supply Input		Single-Phase 200~240V / Three-Phase 200~240V				
Frequency		50/60Hz				
Permissible Frequency Range		±5%				
Rated Input Current		Single-Phase : 0.55A Three-Phase : 0.32A	Single-Phase : 0.92A Three-Phase : 0.53A	Single-Phase : 1.61A Three-Phase : 0.93A	Single-Phase : 2.34A Three-Phase : 1.35A	Single-Phase : 3.88A Three-Phase : 2.24A
Maximum Input Current		Single-Phase : 1.65A Three-Phase : 0.95A	Single-Phase : 2.76A Three-Phase : 1.59A	Single-Phase : 4.83A Three-Phase : 2.79A	Single-Phase : 7.02A Three-Phase : 4.05A	Single-Phase : 11.64A Three-Phase : 6.72A
Environment	Temperature	<ul style="list-style-type: none"> <li>· In Use : 0~40°C</li> <li>· In Storage : -20~70°C</li> </ul>				
	Humidity	<ul style="list-style-type: none"> <li>· In Use : 35~85% RH (Non-Condensing)</li> <li>· In Storage : 10~90% RH (Non-Condensing)</li> </ul>				
	Vibration resistant	0.5g				
Function	Speed Control Range	50~4,000r/min				
	Rated Speed	3,000r/min				
	Speed Regulation	0.2% or less / Conditions: 0~Rated Torque, Rated Speed, Rated Voltage, normal Temperature				
	Rated Torque	0.096N·m	0.192N·m	0.382N·m	0.637N·m	1.272N·m
	Maximum Instantaneous Torque	0.144N·m	0.287N·m	0.573N·m	1.15N·m	1.91N·m
	Rated Output Current	0.21A	0.36A	0.85A	1.65A	2.37A
	Error Types	Under voltage Error, Over voltage Error, Over heat Error, Over current Error, Speed feedback Error, Sensor Error, Over speed Error, Over load Error, Operation at power-on Error, External Error				
I/O Signal	Input Signal Function	5 user inputs (Photocoupler)				
	Output Signal Function	3 user outputs (Photocoupler)				



● Dimensions of Drive [mm]

1. 30, 60, 120W Drive

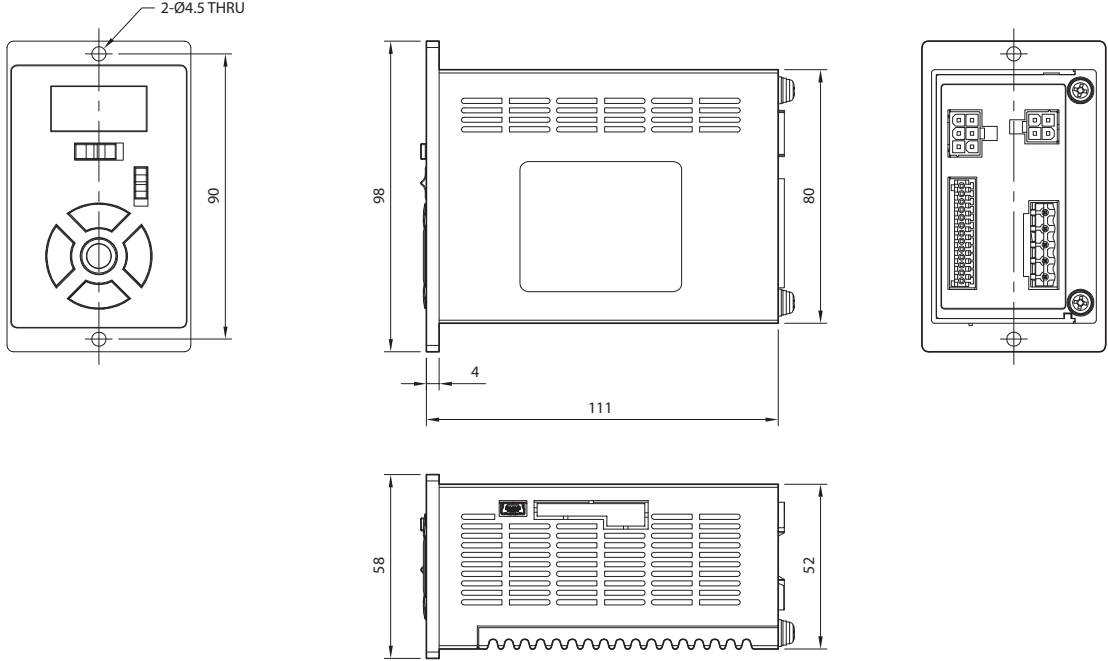

2. 200, 400W Drive

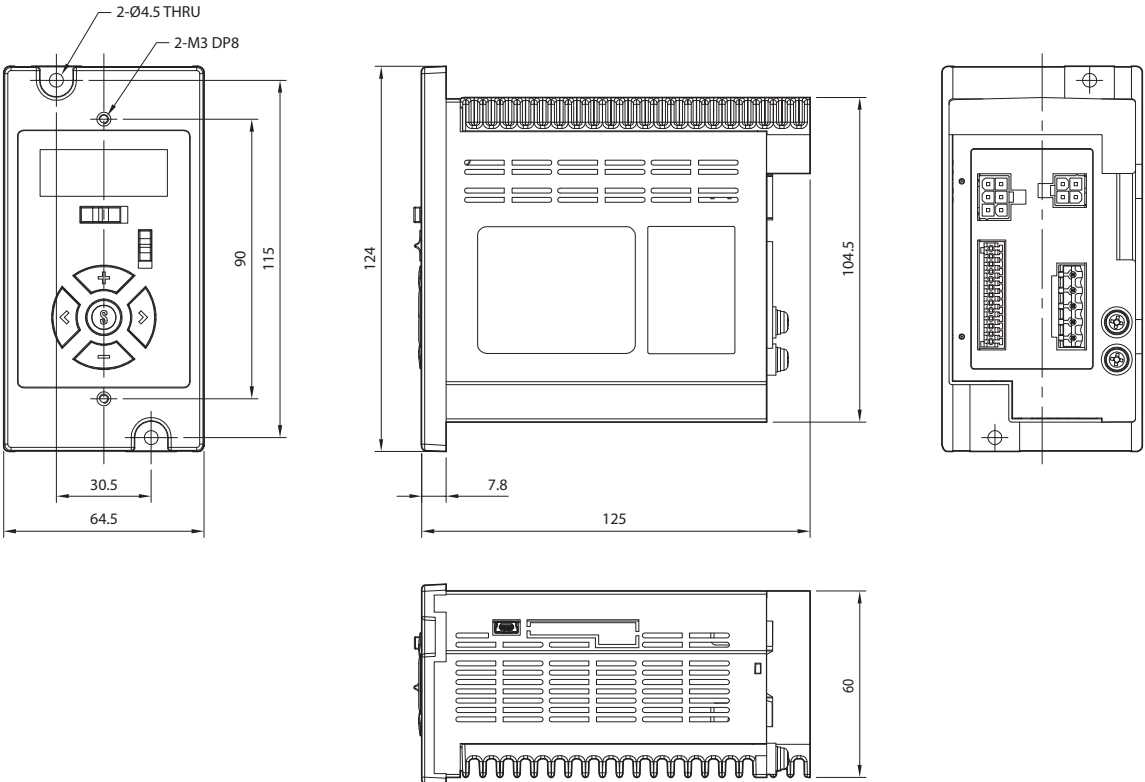

## ● Specifications of Motor

MODEL			UNIT	ESM-60-S-30	ESM-80-S-60	ESM-90-S-120	ESM-104-S-200	ESM-104-S-400
RATED OUTPUT POWER (CONTINUOUS)			W	30	60	120	200	400
RATED TORQUE			N·m	0,096	0,192	0,382	0,637	1,272
RATED INPUT CURRENT			A	0,21	0,36	0,85	1,65	2,37
RATED SPEED			r/min	3,000				
PERMISSIBLE LOAD INERTIA MOMENT			$10^{-4}\text{kg}\cdot\text{m}^2$	0,5	1,8	5,8	5,8	8,75
INERTIA MOMENT			$10^{-4}\text{kg}\cdot\text{m}^2$	0,086	0,234	0,61	0,61	0,66
WEIGHT			kg	0,5	0,8	1,3	2,4	2,4
LENGTH			mm	62	74	94	156	156
PERMISSIBLE OVERHUNG LOAD	DISTANCE FROM SHAFT END	10mm	N	70	120	160	197	197
		20mm		100	140	170	220	220

# Torque Characteristics of Motor

Ezi-SPEED-30W

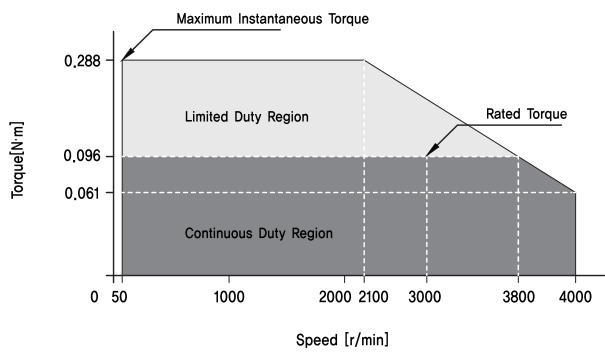

Ezi-SPEED-60W

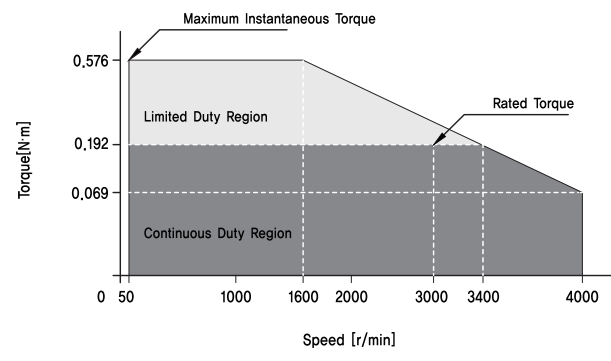

Ezi-SPEED-120W

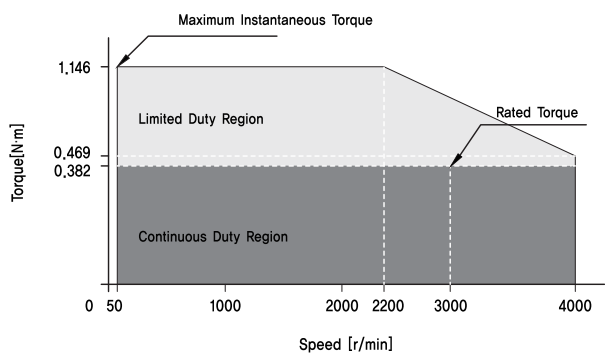

Ezi-SPEED-200W

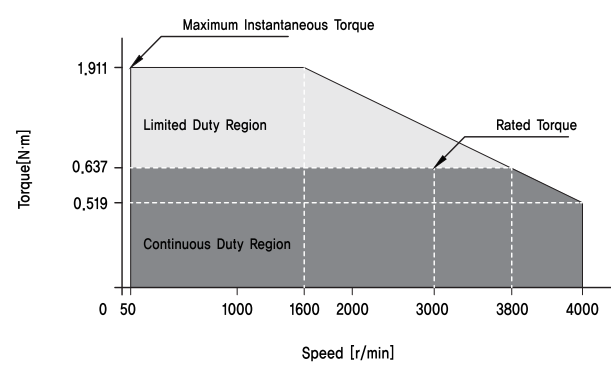

Ezi-SPEED-400W

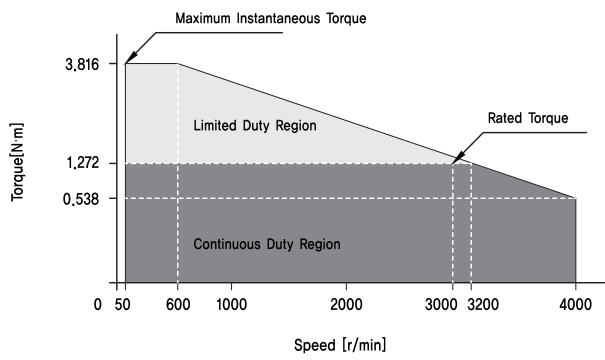

## ● Dimensions of Motor [mm]

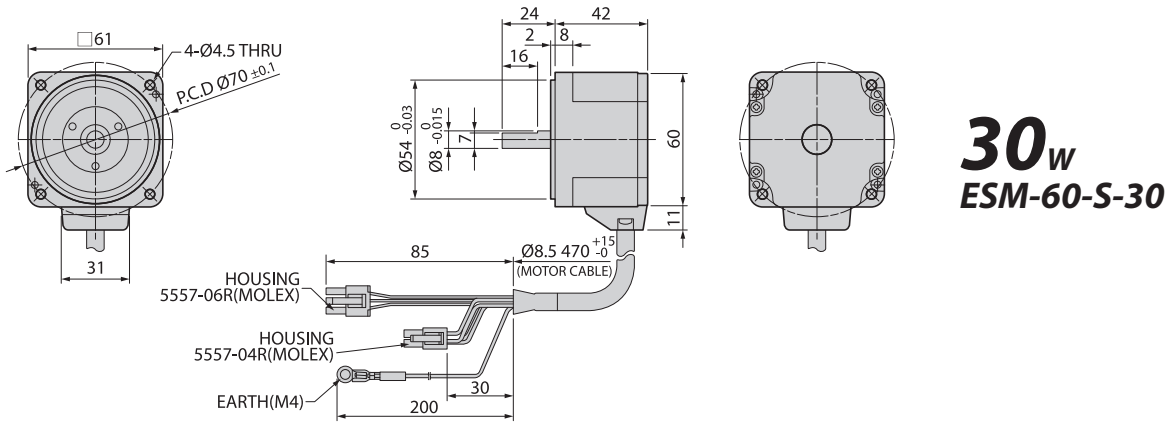

**30<sub>W</sub>**  
**ESM-60-S-30**

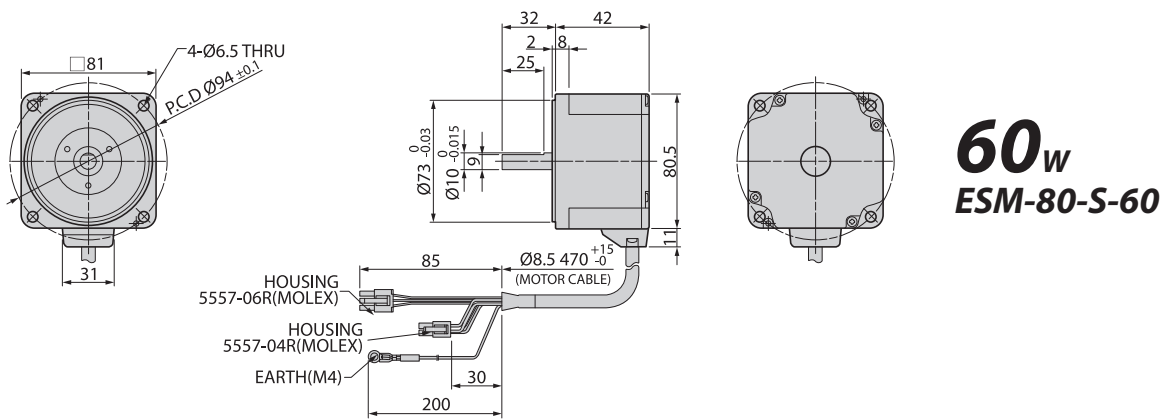

**60<sub>W</sub>**  
**ESM-80-S-60**

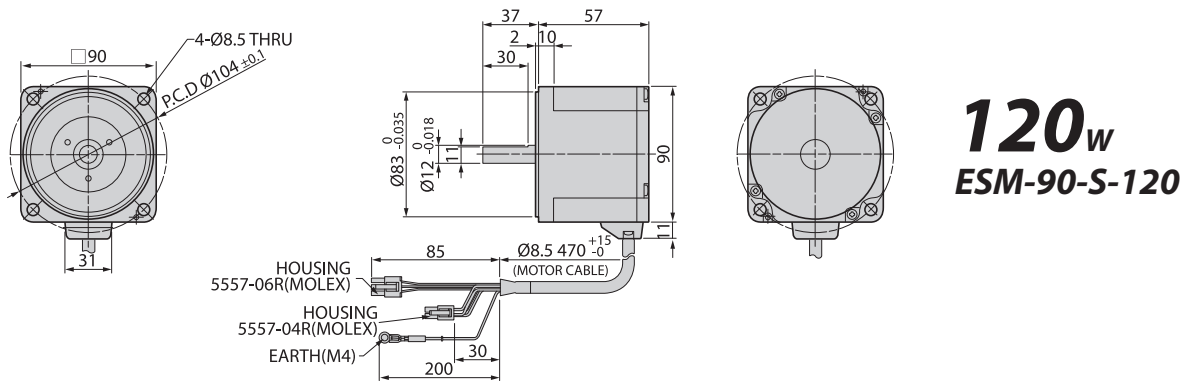

**120<sub>W</sub>**  
**ESM-90-S-120**

● Dimensions of Motor [mm]

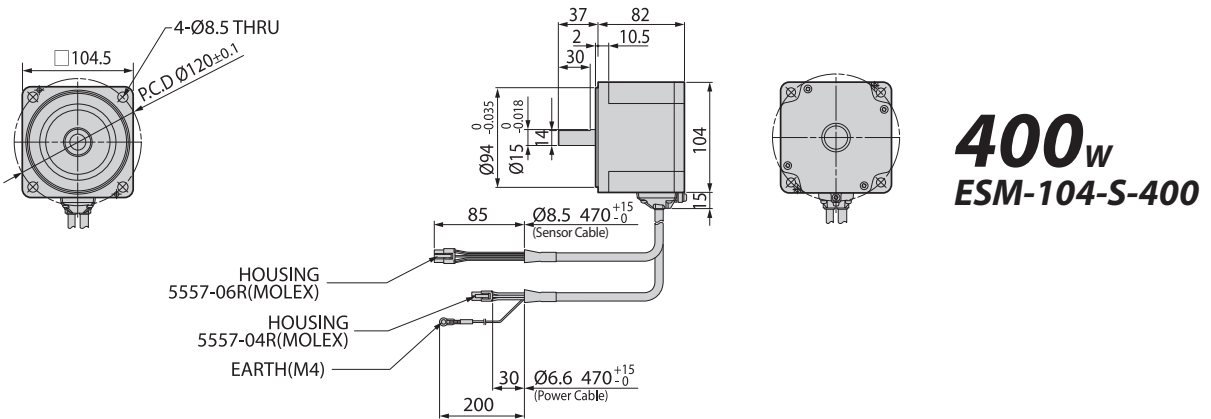
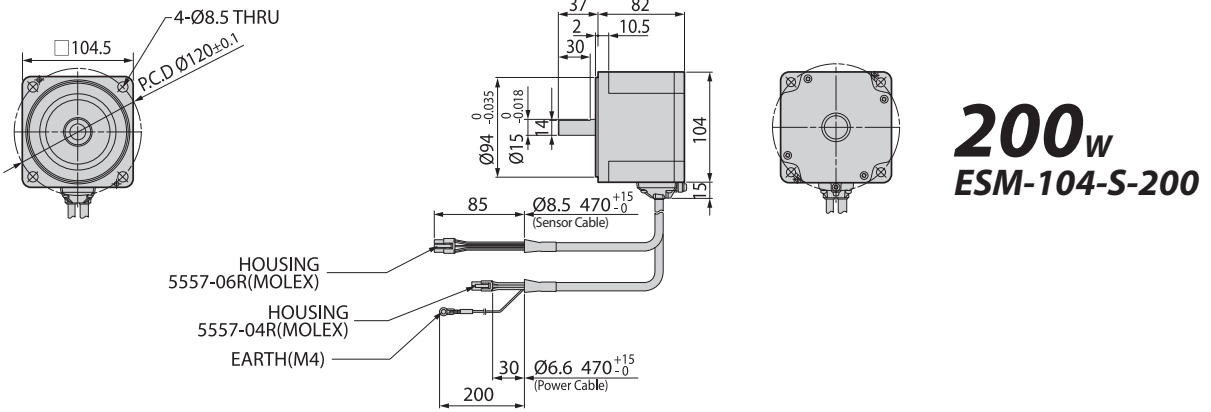

## ● Specifications of Motor with Parallel Shaft Gearbox

### 30<sub>w</sub>

Unit Part Number	Gear Ratio	Permitted Torque [N·m]		Permitted Speed Range [r/min]	Unit Weight [kg]	Permitted Overhung Load [N]		Permitted Thrust Load [N]
		50~3,000 [r/min]	4,000 [r/min]			Distance From Shaft End [mm]		
						10	20	
Ezi-SPEED-60-H-30-C-R5-P	5	0,45	0,34	10~800	0,9	100	150	40
Ezi-SPEED-60-H-30-C-R10-P	10	0,9	0,68	5~400		150	200	
Ezi-SPEED-60-H-30-C-R15-P	15	1,35	1	3,3~266,7				
Ezi-SPEED-60-H-30-C-R20-P	20	1,8	1,4	2,5~200				
Ezi-SPEED-60-H-30-C-R30-P	30	2,6	1,9	1,7~133,3		200	300	
Ezi-SPEED-60-H-30-C-R50-P	50	4,3	3,2	1~80				
Ezi-SPEED-60-H-30-C-R100-P	100	6	5,4	0,5~40				
Ezi-SPEED-60-H-30-C-R200-P	200	6	5,4	0,25~20				

### 60<sub>w</sub>

Unit Part Number	Gear Ratio	Permitted Torque [N·m]		Permitted Speed Range [r/min]	Unit Weight [kg]	Permitted Overhung Load [N]		Permitted Thrust Load [N]
		50~3,000 [r/min]	4,000 [r/min]			Distance From Shaft End [mm]		
						10	20	
Ezi-SPEED-80-H-60-C-R5-P	5	0,9	0,68	10~800	1,6	200	250	100
Ezi-SPEED-80-H-60-C-R10-P	10	1,8	1,4	5~400		300	350	
Ezi-SPEED-80-H-60-C-R15-P	15	2,7	2	3,3~266,7				
Ezi-SPEED-80-H-60-C-R20-P	20	3,6	2,7	2,5~200				
Ezi-SPEED-80-H-60-C-R30-P	30	5,2	3,9	1,7~133,3		450	550	
Ezi-SPEED-80-H-60-C-R50-P	50	8,6	6,5	1~80				
Ezi-SPEED-80-H-60-C-R100-P	100	16	12,9	0,5~40				
Ezi-SPEED-80-H-60-C-R200-P	200	16	14	0,25~20				

### 120<sub>w</sub>

Unit Part Number	Gear Ratio	Permitted Torque [N·m]		Permitted Speed Range [r/min]	Unit Weight [kg]	Permitted Overhung Load [N]		Permitted Thrust Load [N]
		50~3,000 [r/min]	4,000 [r/min]			Distance From Shaft End [mm]		
						10	20	
Ezi-SPEED-90-H-120-C-R5-P	5	2,2	1,4	10~800	2,7	300	400	150
Ezi-SPEED-90-H-120-C-R10-P	10	4,4	2,7	5~400		400	500	
Ezi-SPEED-90-H-120-C-R15-P	15	6,6	4,1	3,3~266,7				
Ezi-SPEED-90-H-120-C-R20-P	20	8,8	5,4	2,5~200				
Ezi-SPEED-90-H-120-C-R30-P	30	12,6	7,7	1,7~133,3		500	650	
Ezi-SPEED-90-H-120-C-R50-P	50	21,1	12,9	1~80				
Ezi-SPEED-90-H-120-C-R100-P	100	30	25,8	0,5~40				
Ezi-SPEED-90-H-120-C-R200-P	200	30	27	0,25~20				

## ● Specifications of Motor with Parallel Shaft Gearbox

### 200<sub>w</sub>

Unit Part Number	Gear Ratio	Permitted Torque [N·m]		Permitted Speed Range [r/min]	Unit Weight [kg]	Permitted Overhung Load [N]		Permitted Thrust Load [N]
		50~3,000 [r/min]	4,000 [r/min]			Distance From Shaft End [mm]		
						10	20	
Ezi-SPEED-104-H-200-C-R5-P	5	2,9	2	10~800	4,2	550	800	200
Ezi-SPEED-104-H-200-C-R10-P	10	5,9	4,1	5~400				
Ezi-SPEED-104-H-200-C-R15-P	15	8,8	6,1	3,3~266,7				
Ezi-SPEED-104-H-200-C-R20-P	20	11,7	8,1	2,5~200		1,000	1,250	300
Ezi-SPEED-104-H-200-C-R30-P	30	16,8	11,6	1,7~133,3				
Ezi-SPEED-104-H-200-C-R50-P	50	28	19,4	1~80				
Ezi-SPEED-104-H-200-C-R100-P	100	52,7	36,5	0,5~40		1,400	1,700	400
Ezi-SPEED-104-H-200-C-R200-P	200	70	63	0,25~20				

### 400<sub>w</sub>

Unit Part Number	Gear Ratio	Permitted Torque [N·m]		Permitted Speed Range [r/min]	Unit Weight [kg]	Permitted Overhung Load [N]		Permitted Thrust Load [N]
		50~3,000 [r/min]	4,000 [r/min]			Distance From Shaft End [mm]		
						10	20	
Ezi-SPEED-104-H-400-C-R5-P	5	5,9	4,3	10~800	4,2	550	800	200
Ezi-SPEED-104-H-400-C-R10-P	10	11,7	8,6	5~400				
Ezi-SPEED-104-H-400-C-R15-P	15	17,6	12,8	3,3~266,7				
Ezi-SPEED-104-H-400-C-R20-P	20	23,4	17,1	2,5~200		1,000	1,250	300
Ezi-SPEED-104-H-400-C-R30-P	30	33,5	24,5	1,7~133,3				
Ezi-SPEED-104-H-400-C-R50-P	50	55,9	40,9	1~80				
Ezi-SPEED-104-H-400-C-R100-P	100	70	63	0,5~40		1,400	1,700	400
Ezi-SPEED-104-H-400-C-R200-P	200	70	63	0,25~20				

## ● Specifications of Motor with Hollow Shaft Gearbox

### 30<sub>w</sub>

Unit Part Number	Gear Ratio	Permitted Torque [N·m]		Permitted Speed Range [r/min]	Unit Weight [kg]	Permitted Overhung Load [N]		Permitted Thrust Load [N]
		50~3,000 [r/min]	4,000 [r/min]			Distance From Shaft End [mm]		
						10	20	
Ezi-SPEED-60-H-30-C-R5-H	5	0,4	0,3	10~800	1,2	450	370	200
Ezi-SPEED-60-H-30-C-R10-H	10	0,85	0,64	5~400				
Ezi-SPEED-60-H-30-C-R15-H	15	1,3	0,96	3,3~266,7		500	400	
Ezi-SPEED-60-H-30-C-R20-H	20	1,7	1,3	2,5~200				
Ezi-SPEED-60-H-30-C-R30-H	30	2,6	1,9	1,7~133,3				
Ezi-SPEED-60-H-30-C-R50-H	50	4,3	3,2	1~80				
Ezi-SPEED-60-H-30-C-R100-H	100	8,5	6,4	0,5~40				
Ezi-SPEED-60-H-30-C-R200-H	200	17	12,8	0,25~20				

### 60<sub>w</sub>

Unit Part Number	Gear Ratio	Permitted Torque [N·m]		Permitted Speed Range [r/min]	Unit Weight [kg]	Permitted Overhung Load [N]		Permitted Thrust Load [N]
		50~3,000 [r/min]	4,000 [r/min]			Distance From Shaft End [mm]		
						10	20	
Ezi-SPEED-80-H-60-C-R5-H	5	0,85	0,64	10~800	2,2	800	660	400
Ezi-SPEED-80-H-60-C-R10-H	10	1,7	1,3	5~400				
Ezi-SPEED-80-H-60-C-R15-H	15	2,6	1,9	3,3~266,7		1,200	1,000	
Ezi-SPEED-80-H-60-C-R20-H	20	3,4	2,6	2,5~200				
Ezi-SPEED-80-H-60-C-R30-H	30	5,1	3,8	1,7~133,3				
Ezi-SPEED-80-H-60-C-R50-H	50	8,5	6,4	1~80				
Ezi-SPEED-80-H-60-C-R100-H	100	17	12,8	0,5~40				
Ezi-SPEED-80-H-60-C-R200-H	200	34	25,5	0,25~20				

### 120<sub>w</sub>

Unit Part Number	Gear Ratio	Permitted Torque [N·m]		Permitted Speed Range [r/min]	Unit Weight [kg]	Permitted Overhung Load [N]		Permitted Thrust Load [N]
		50~3,000 [r/min]	4,000 [r/min]			Distance From Shaft End [mm]		
						10	20	
Ezi-SPEED-90-H-120-C-R5-H	5	2,1	1,3	10~800	3,3	900	770	500
Ezi-SPEED-90-H-120-C-R10-H	10	4,2	2,6	5~400				
Ezi-SPEED-90-H-120-C-R15-H	15	6,2	3,8	3,3~266,7		1,300	1,000	
Ezi-SPEED-90-H-120-C-R20-H	20	8,3	5,1	2,5~200				
Ezi-SPEED-90-H-120-C-R30-H	30	12,5	7,7	1,7~133,3				
Ezi-SPEED-90-H-120-C-R50-H	50	21	12,8	1~80		1,500	1,280	
Ezi-SPEED-90-H-120-C-R100-H	100	42	25,5	0,5~40				
Ezi-SPEED-90-H-120-C-R200-H	200	68	51	0,25~20				



## ● Specifications of Motor with Hollow Shaft Gearbox

### 200<sub>w</sub>

Unit Part Number	Gear Ratio	Permitted Torque [N·m]		Permitted Speed Range [r/min]	Unit Weight [kg]	Permitted Overhung Load [N]		Permitted Thrust Load [N]
		50~3,000 [r/min]	4,000 [r/min]			Distance From Shaft End [mm]		
						10	20	
Ezi-SPEED-104-H-200-C-R5-H	5	2,8	1,9	10~800	4,2	1,230	1,070	800
Ezi-SPEED-104-H-200-C-R10-H	10	5,5	3,8	5~400				
Ezi-SPEED-104-H-200-C-R15-H	15	8,3	5,7	3,3~266,7		1,680	1,470	
Ezi-SPEED-104-H-200-C-R20-H	20	11,1	7,7	2,5~200				
Ezi-SPEED-104-H-200-C-R30-H	30	16,6	11,5	1,7~133,3		2,040	1,780	
Ezi-SPEED-104-H-200-C-R50-H	50	27,6	19,1	1~80				
Ezi-SPEED-104-H-200-C-R100-H	100	55,3	38,3	0,25~20				

### 400<sub>w</sub>

Unit Part Number	Gear Ratio	Permitted Torque [N·m]		Permitted Speed Range [r/min]	Unit Weight [kg]	Permitted Overhung Load [N]		Permitted Thrust Load [N]
		50~3,000 [r/min]	4,000 [r/min]			Distance From Shaft End [mm]		
						10	20	
Ezi-SPEED-104-H-400-C-R5-H	5	5,5	4,0	10~800	4,2	1,230	1,070	800
Ezi-SPEED-104-H-400-C-R10-H	10	11,1	8,1	5~400				
Ezi-SPEED-104-H-400-C-R15-H	15	16,6	12,1	3,3~266,7		1,680	1,470	
Ezi-SPEED-104-H-400-C-R20-H	20	22,1	16,2	2,5~200				
Ezi-SPEED-104-H-400-C-R30-H	30	33,2	24,2	1,7~133,3		2,040	1,780	
Ezi-SPEED-104-H-400-C-R50-H	50	55,3	40,4	1~80				
Ezi-SPEED-104-H-400-C-R100-H	100	110	80,8	0,5~40				

## ● Dimensions of Motor with Parallel Shaft Gearbox [mm]

# 30<sub>w</sub>

Unit Part Number	Gearbox Part Number	□ Gear Ratio	Mounting Bolt	L [mm]
Ezi-SPEED-60-H-30-C-R□-P	ESG-60-H-R□-P	5, 10, 15, 20	M4×50	34
		30, 50, 100	M4×55	38
		200	M4×60	43

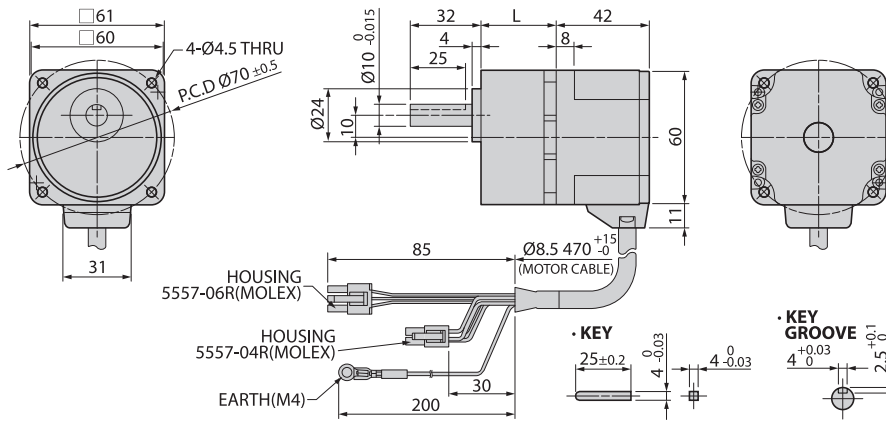

# 60<sub>w</sub>

Unit Part Number	Gearbox Part Number	□ Gear Ratio	Mounting Bolt	L [mm]
Ezi-SPEED-80-H-60-C-R□-P	ESG-80-H-R□-P	5, 10, 15, 20	M4×65	41
		30, 50, 100	M4×70	46
		200	M4×75	51

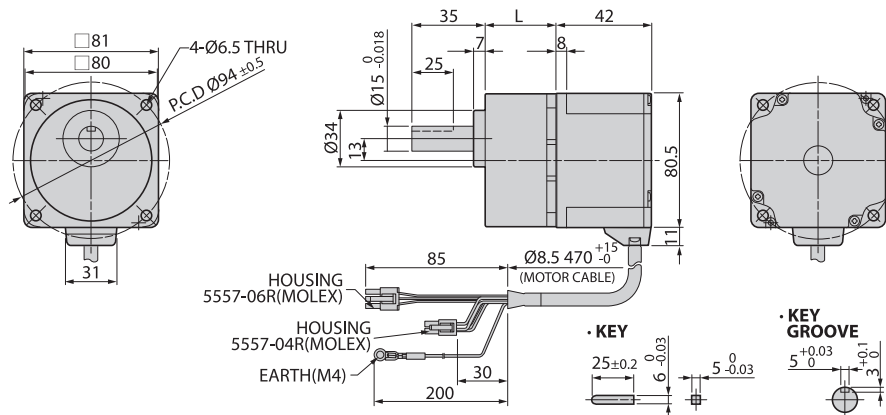

## ● Dimensions of Motor with Parallel Shaft Gearbox [mm]

### 120<sub>w</sub>

Unit Part Number	Gearbox Part Number	□ Gear Ratio	Mounting Bolt	L [mm]
Ezi-SPEED-90-H-120-C-R□-P	ESG-90-H-R□-P	5, 10, 15, 20	M8×75	45
		30, 50, 100	M8×90	58
		200	M8×95	64

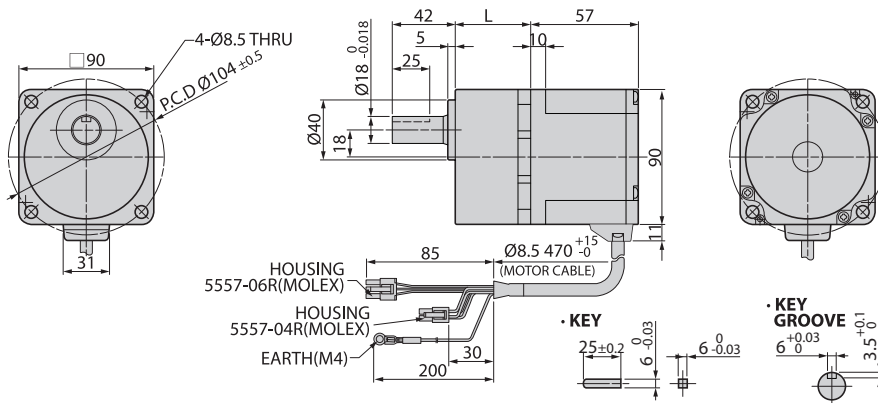

### 200<sub>w</sub>

Unit Part Number	Gearbox Part Number	□ Gear Ratio	Mounting Bolt	L [mm]
Ezi-SPEED-104-H-200-C-R□-P	ESG-104-H-R□-P	5, 10, 15, 20	M8×95	60
		30, 50	M8×110	72
		100, 200	M8×120	86

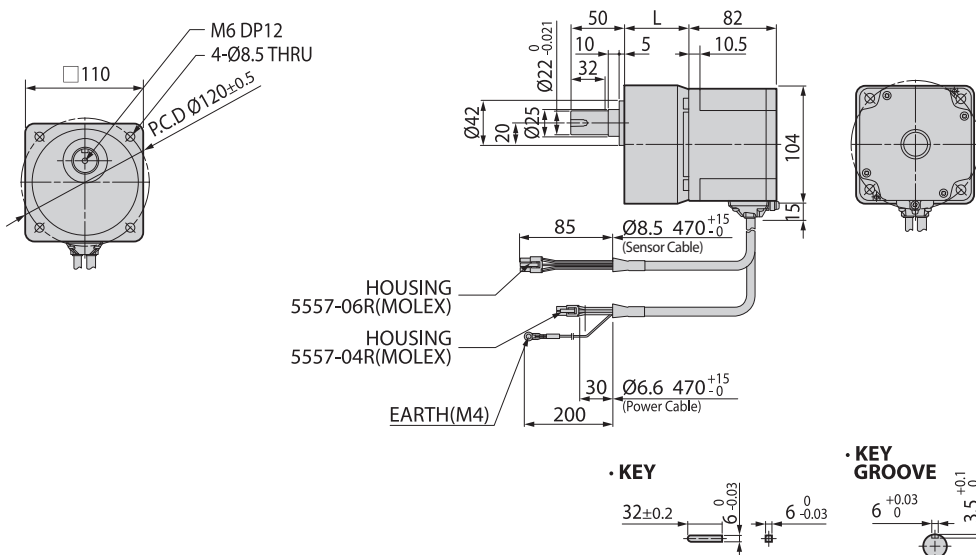

● Dimensions of Motor with Parallel Shaft Gearbox [mm]

# 400<sub>w</sub>

Unit Part Number	Gearbox Part Number	□ Gear Ratio	Mounting Bolt	L [mm]
Ezi-SPEED-104-H-400-C-R□-P	ESG-104-H-R□-P	5, 10, 15, 20	M8×95	60
		30, 50	M8×110	72
		100, 200	M8×120	86

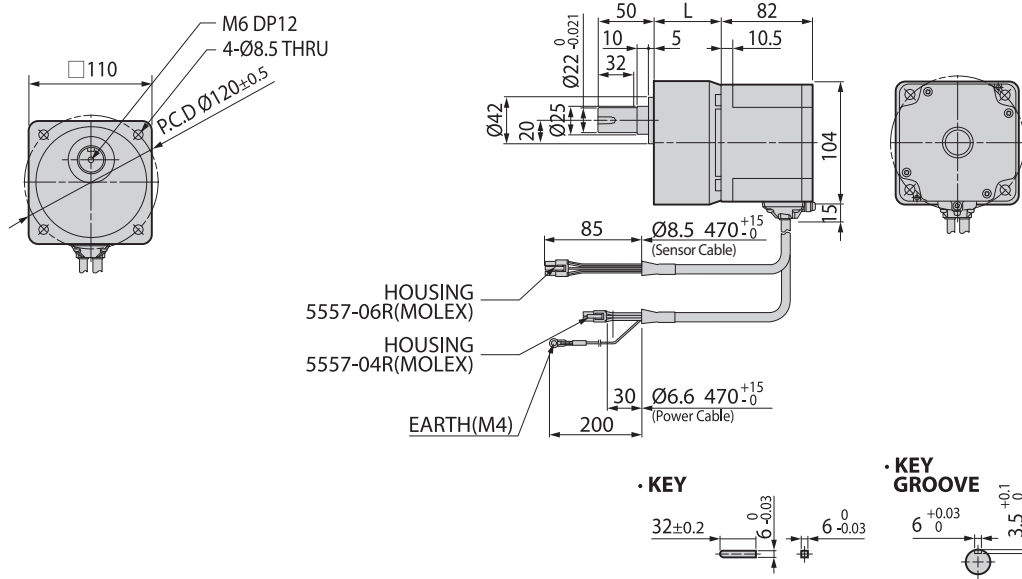

● Dimensions of Motor with Hollow Shaft Gearbox [mm]

# 30<sub>w</sub>

Unit Part Number	Gearbox Part Number	□ Gear Ratio	Mounting Bolt
Ezi-SPEED-60-H-30-C-R□-H	ESG-60-H-R□-H	5, 10, 15, 20, 30, 50, 100, 200	M5×65

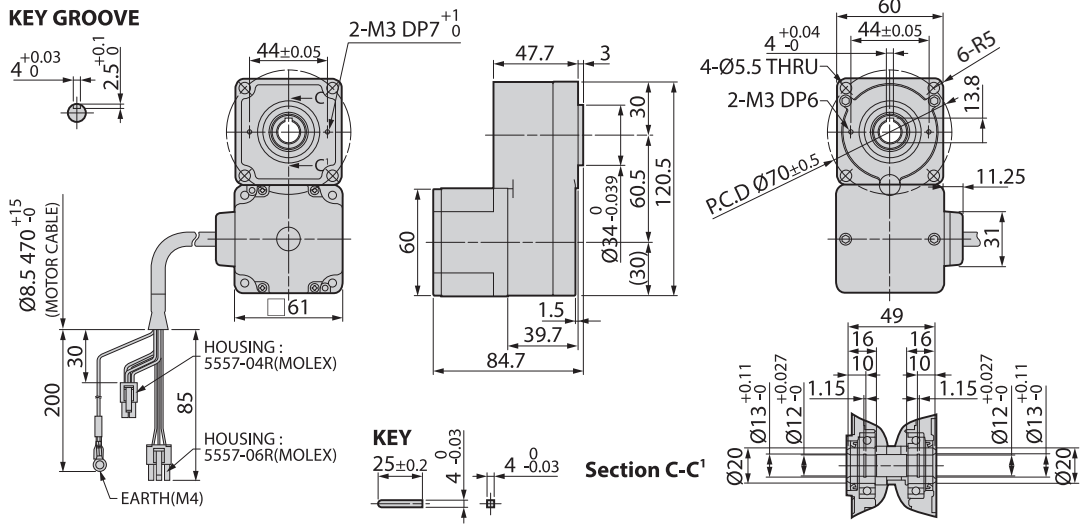

# 60<sub>w</sub>

Unit Part Number	Gearbox Part Number	□ Gear Ratio	Mounting Bolt
Ezi-SPEED-80-H-60-C-R□-H	ESG-80-H-R□-H	5, 10, 15, 20, 30, 50, 100, 200	M6×70

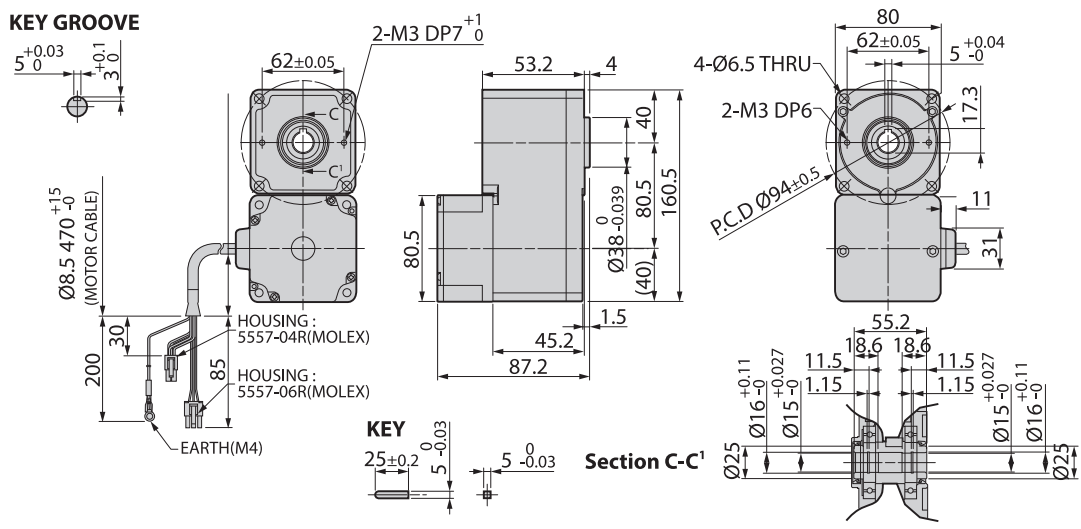

## ● Dimensions of Motor with Hollow Shaft Gearbox [mm]

# 120<sub>w</sub>

Unit Part Number	Gearbox Part Number	□ Gear Ratio	Mounting Bolt
Ezi-SPEED-90-H-120-C-R□-H	ESG-90-H-R□-H	5, 10, 15, 20, 30, 50, 100, 200	M8×90

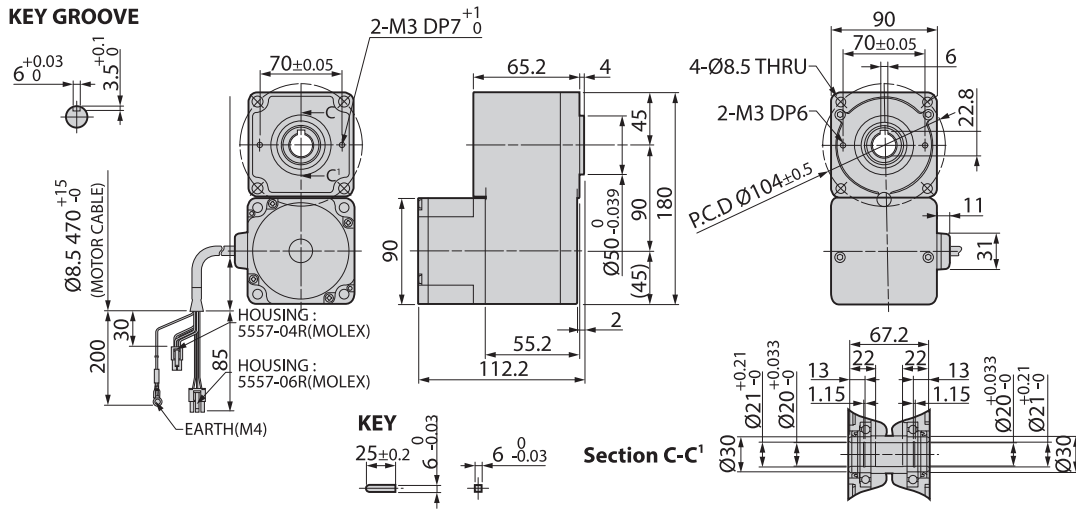

# 200<sub>w</sub>

Unit Part Number	Gearbox Part Number	□ Gear Ratio	Mounting Bolt
Ezi-SPEED-104-H-200-C-R□-H	ESG-104-H-R□-H	5, 10, 15, 20, 30, 50, 100	M8×90

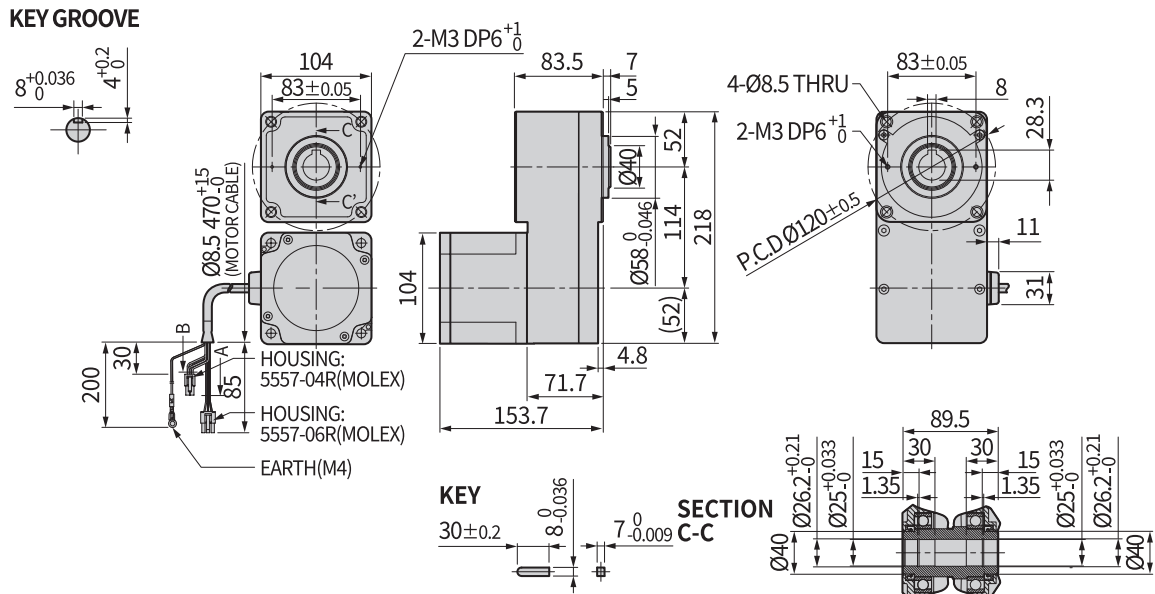

● Dimensions of Motor with Hollow Shaft Gearbox [mm]

# 400<sub>w</sub>

Unit Part Number	Gearbox Part Number	□ Gear Ratio	Mounting Bolt
Ezi-SPEED-104-H-400-C-R□-H	ESG-104-H-R□-H	5, 10, 15, 20, 30, 50, 100	M8×90

**KEY GROOVE**

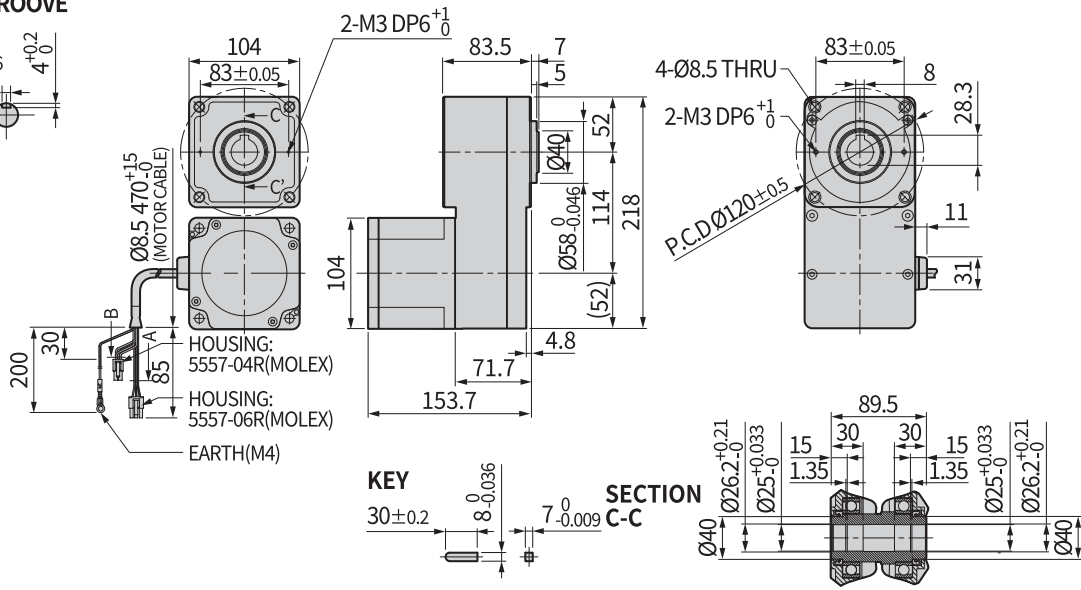
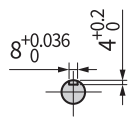

## ● Settings and Operation

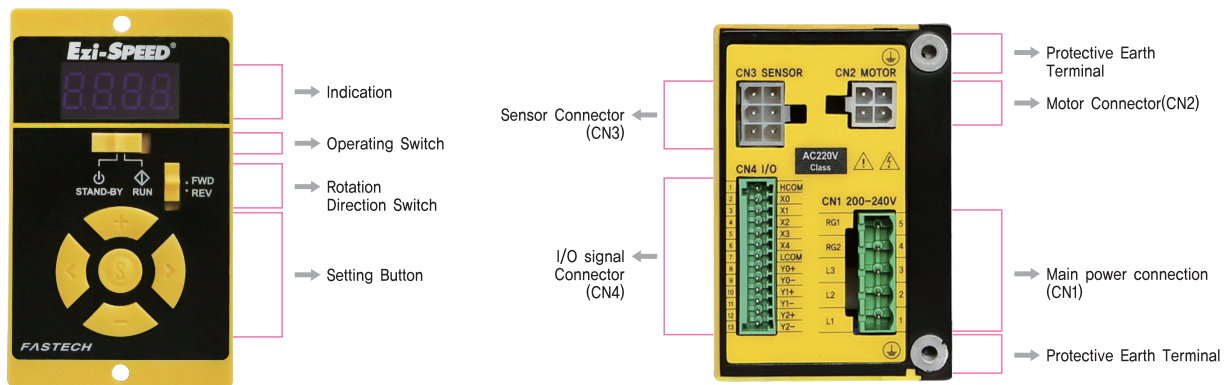

### 1. Setting

Indication	Conditions
Indication	Display the monitoring items, parameter, alarm, warning, etc
Operating Switch	The motor is started by setting it to the "RUN" position Setting it to the "STAND-BY" position stop the motor
Rotation Direction Switch	Change the rotation direction of the motor with rotation direction switch
Setting Button	Changes the speed and parameters The value is set when the "S" button is pressed after changes are made
Protective Earth Terminal	Ground either one of the protective earth terminals
Sensor Connection(CN3)	Connects to the signal Connection of the motor
Motor Connection(CN2)	Connects to the power Connection of the motor
I/O Signal Connection(CN4)	Connects with the I/O signals
Main Power Connection(CN1)	Connects to the main power supply and regenerative resistor

#### ● Extended Functions

Ezi-SPEED can be perform various setting by operation button

Operating Mode	Conditions
Monitor Mode	Speed, Actual speed, Load factor, Alarm record and reset, Warning record and reset, Operating data number, I/O monitor
Data Mode	Data 8 points, Operating speed, Acceleration time, Deceleration time, Operating data reset
Parameter Mode	The acceleration/deceleration time, The overload alarm detection time, The speed upper limit and lower limit, Speed reduction ratio, Speed increasing ratio, Panel initial view, Alarm of "Run" condition at power on, External operation signal input, External input function, External output function, Speed attainment width, Parameter mode reset
NVM Saving Mode	Parameter save to NVM(Non-Volatile Memory)



## 2. Main Power Connector(CN1)

NO.	Function	I/O
1	L1	Input
2	L2	Input
3	L3	Input
4	RG2	Input
5	RG1	Input

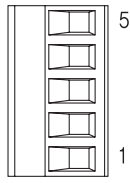

\* Use RG1, RG2 terminals when connecting a regenerative resistor.  
A regenerative resistor can be used when the deceleration time is short or large inertia is used

\* Please refer to the manual for details of regenerative resistor specification

### • Main Power Connection(CN1)

Single-Phase : 200~240V

Three-Phase : 200~240V

Regenerative Resistor

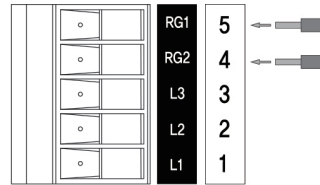
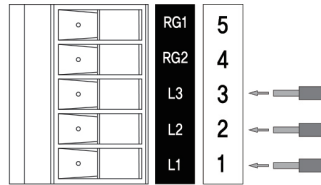
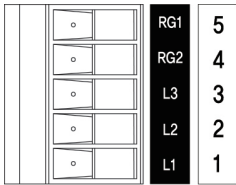

### • Applicable Lead Wire Size

AWG18~14 (0.75~2.0mm<sup>2</sup>)

## 3. Motor Connector(CN2)

NO.	Function	I/O
1	—	—
2	BLDC_U	Output
3	BLDC_W	Output
4	BLDC_V	Output

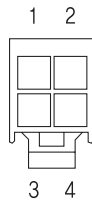

## 4. Sensor Connector(CN3)

NO.	Function	I/O
1	DC5V	Output
2	GND	—
3	GND	Output
4	HALL_U	Input
5	HALL_V	Input
6	HALL_W	Input

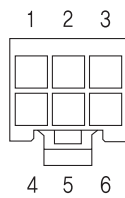

## 5. I/O Signal Connector(CN4)

NO.	Function	I/O
1	HCOM	Common
2	X0	Input
3	X1	Input
4	X2	Input
5	X3	Input
6	X4	Input
7	LCOM	Common
8	Y0+	Output
9	Y0-	Output
10	Y1+	Output
11	Y1-	Output
12	Y2+	Output
13	Y2-	Output

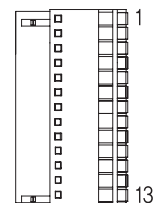

### • Applicable Lead Wire Size

AWG26~20 (0.14~0.5mm<sup>2</sup>)

## ● System Configuration [30, 60, 120W]

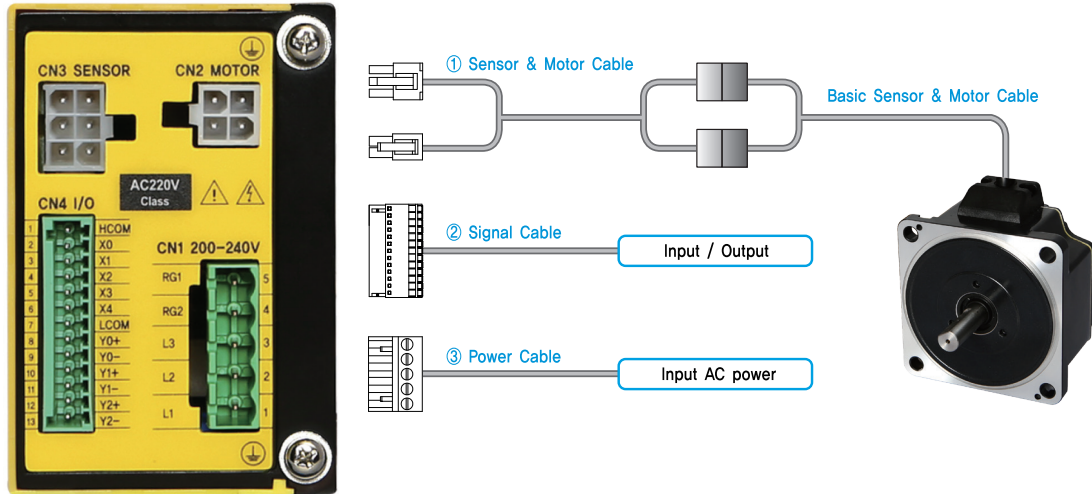

Cable Type	Max. Length	Remarks
① Sensor & Motor Cable	10m	Options (Sold separately)
② Signal Cable	20m	This cable is not provided or sold by FASTECH.
③ Power Cable	3m	
Basic Sensor & Motor Cable	0,5m	Basic cables are attached to motors.

### 1. Accessories

#### Connectors

Connector specifications for cabling to drive.

Purpose	Item	Part Number	Manufacturer
Power (CN1)	Terminal Block	CPF5,08-05P	STELVIO
Motor (CN2)	Drive Side (CN2)	Housing	5557-04R
		Terminal	5556T
	Motor Side	Housing	5559-04P
		Terminal	5558T
Sensor (CN3)	Drive Side (CN3)	Housing	5557-06R
		Terminal	5556T
	Motor Side	Housing	5559-06P
		Terminal	5558T
Signal (CN4)	Terminal Block	15EDGKD-13P	DEGSON

※ The connectors above are supplied with the product. If you are using other parts, please make sure they meet the specifications

## 2. Options

### Sensor/Motor Extension Cable

These are the cables to connect the drive for 30W, 60W and 120W to a sensor and a motor.

Purpose	Item	Length [m]	Cable Type	Remarks
Drive – Basic Sensor/Motor Cable Connection	CSPD-S-001F	1	Normal Cable	Max Length : 10m
	CSPD-S-002F	2		
	CSPD-S-003F	3		
	CSPD-S-005F	5		
	CSPD-S-007F	7		
	CSPD-S-010F	10		

### Regenerative resistor

It prevents over voltage alarm when it is used with heavy load and short deceleration time.

Purpose	Product No.	Specifications		Product image
Regenerative resistor	BRM-A100W-400J	Resistance	400 $\Omega$	
		Wattage	100 W	
		Cable length	30 cm	

## ● System Configuration [200, 400W]

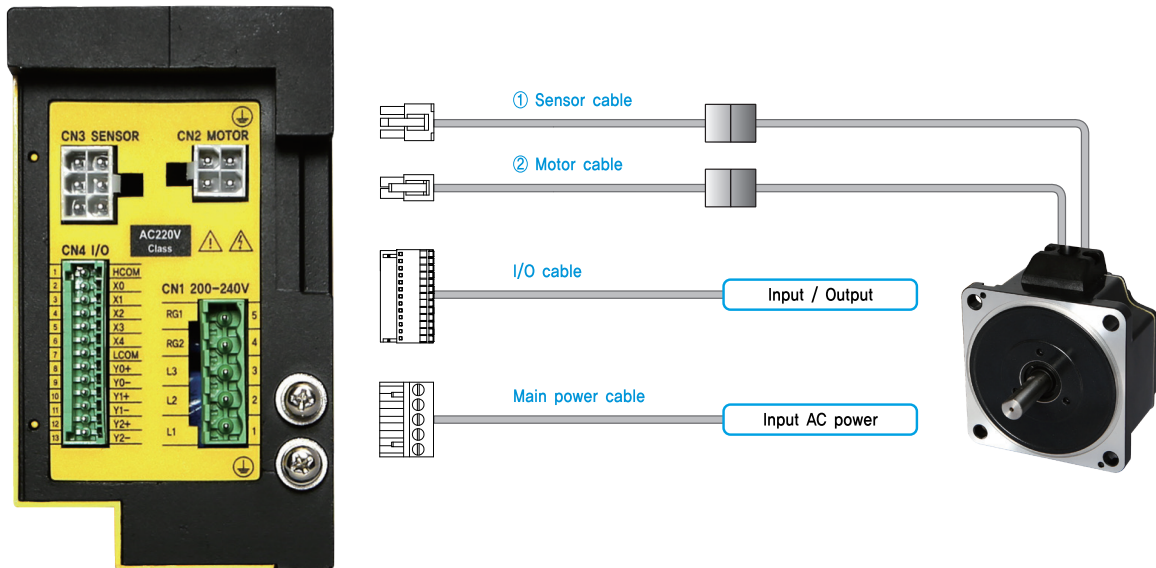

Cable Type	Max. Length	Remarks
① Sensor Cable	10m	Options (Sold separately)
② Motor Cable	10m	
③ Signal Cable	20m	This cable is not provided or sold by FASTECH.
④ Power Cable	3m	
Basic Sensor Cable	0,5m	Basic cables are attached to motors.
Basic Motor Cable	0,5m	

### 1. Accessories

#### Connectors

Connector specifications for cabling to drive.

Purpose	Item	Part Number	Manufacturer	
Power (CN1)	Terminal Block	CPF5,08-05P	STELVIO	
Motor (CN2)	Drive Side (CN2)	Housing	5557-04R	MOLEX
		Terminal	5556T	
	Motor Side	Housing	5559-04P	MOLEX
		Terminal	5558T	
Sensor (CN3)	Drive Side (CN3)	Housing	5557-06R	MOLEX
		Terminal	5556T	
	Motor Side	Housing	5559-06P	MOLEX
		Terminal	5558T	
Signal (CN4)	Terminal Block	15EDGKD-13P	DEGSON	

※ The connectors above are supplied with the product. If you are using other parts, please make sure they meet the specifications

## 2. Options

### ① Sensor Extension Cable

These are the cables to connect the drive for 200W, 400 and the sensor.

Purpose	Item	Length [m]	Cable Type	Remarks
Drive – Basic Sensor/Motor Cable Connection	CSPD-S-001F	1	Normal Cable	Max Length : 10m
	CSPD-S-002F	2		
	CSPD-S-003F	3		
	CSPD-S-005F	5		
	CSPD-S-007F	7		
	CSPD-S-010F	10		

### ② Motor Extension Cable

These are the cables to connect the drive for 200W, 400W and the motor.

Purpose	Item	Length [m]	Cable Type	Remarks
Drive – Basic Sensor/Motor Cable Connection	CSPD-M-001F	1	Normal Cable	Max Length : 10m
	CSPD-M-002F	2		
	CSPD-M-003F	3		
	CSPD-M-005F	5		
	CSPD-M-007F	7		
	CSPD-M-010F	10		

### ③ Regenerative resistor

It prevents over voltage alarm when it is used with heavy load and short deceleration time.

Purpose	Product No.	Specifications		Product image
Regenerative resistor	BRM-A100W-400J	Resistance	400 $\Omega$	
		Wattage	100 W	
		Cable length	30 cm	

# External Wiring Diagram

## Ezi-SPEED

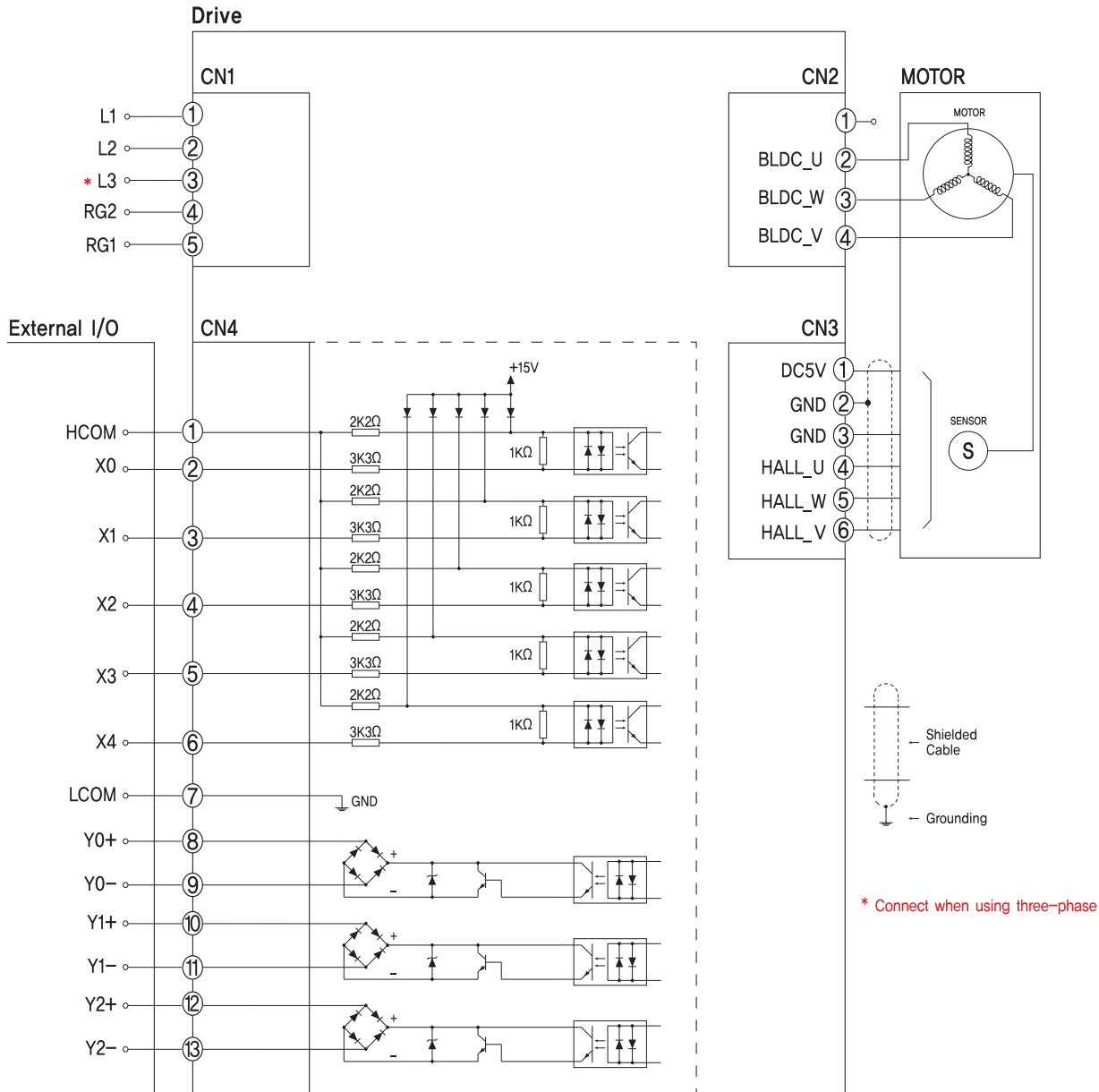

※ When connects I/O cable between controller and drive, please turn off the power of both controller and drive, in order to protect the drive from any damage.

### CAUTION

In order to use the products listed in this catalog safely and correctly, be sure to read the instruction manual before using the product.

**MEMO**



*Fast, Accurate, Smooth Motion*



**บริษัท นานตีอินเตอร์เทรด จำกัด**  
**NANDEE INTER-TRADE CO., LTD.**

314, 316, 318, 320, 322 ซอยจันทน์ 32 ถนนจันทน์ แขวงทุ่งวัดดอน เขตสาทร กทม. 10120

- ☎ : 0-2675-8239
- 📞 : @nandeeintertrade
- 📺 : nandeeintertrade
- 🌐 : www.nandee.co.th
- ✉ : marketing@nandee.co.th  
sales@nandee.co.th