

**EVERWIN**  
TOUGHER FASTER SMARTER

# Carton Stapler



**WARNING**

1. Read and understand the manual. Failure to do so may result in DEATH or SERIOUS INJURY.
2. Operators and others in the area must wear safety glasses at all times.
3. Keep fingers away from the driving batteries to avoid injury.
4. Choice of triggering method. Check manual for options.
5. Disconnect air before service.
6. Always assume that others are unaware of your work.
7. NEVER point tool at yourself or others.
8. NEVER use before or after the expiration date.

Explosion may occur.

CE Max Air pressure: 10 bar

- 1 REAR ADJUSTABLE DIRECTIONAL EXHAUST
- 2 DURABLE DRIVER/BUMPER PROVIDES RELIABILITY
- 3 OPTIONAL SAFETY DOUBLE TRIGGER
- 4 ONE-HAND MANUAL REAR LATCH
- 5 ROBUST METAL MAGAZINE
- 6 RAPID CYCLING ENGINE



**ALM SERIES**  
Auto Fire, Long Magazine



**AUTO SERIES**  
Auto Fire, Short Magazine



FASTENER SPECIFICATION	
Loading Capacity	200~375
Staple Length	5~16mm (3/16"~5/8")
Expect US1013FA(LM) & US1013JA(LM): 5~13mm(3/16"~1/2")	



TOOL SPECIFICATION	
Weight	Short Mag: 0.9 kg (2.0 lbs)
	Long Mag: 1.2 kg (2.6 lbs)
Height	140mm (5.5")
Width	38mm (1.5")
Length	Short Mag: 216mm (8.5")
	Long Mag: 380mm (15")
Operating Pressure	5~6.9 bar (70~100 psi)
Driving Power in-lbs @100 psi	51
Air Consumption L/cycle @90 psi	0.3 (0.64 cfm)
Applications	Furniture Upholstery, Automotive Vinyl, Trim

Model Number	A	B	Capacity	Wire Gauge
USSJK16A / USSJK16ALM	4.1mm (5/32")	0.74 x 0.60mm (0.030" x 0.024")	300	22 GA. Atro SJK
US9716A	4.5mm (3/16")	0.95 x 0.65mm (0.037" x 0.026")	200	21 GA. BeA 97 / Senco W
US5416A / US5416ALM	4.7mm (3/16")	1.25 x 0.50mm (0.049" x 0.020")	200	20 GA. Duo-Fast 54 / Senco E
USSNCW16A / USSNCW16ALM	4.8mm (3/16")	0.90 x 0.69mm (0.035" x 0.027")	200	21 GA. Senco W
USSNCA16A / USSNCA16ALM	4.85mm (3/16")	0.74 x 0.60mm (0.030" x 0.024")	300	22 GA. Senco A / Prebena U
US416JA / US416JALM	5.25mm (7/32")	1.16 x 0.56mm (0.045" x 0.022")	200	20 GA. Duo-Fast 63
US9916A / US9916ALM	5.4mm (7/32")	0.98 x 0.59mm (0.040" x 0.021")	200	21 GA. Atro 99 / Prebena ED
US7116A / US7116ALM	9.1mm (3/8")	0.75 x 0.60mm (0.030" x 0.024")	180	22 GA. 71 Series / Senco C
USSNCG16A / USSNCG16ALM	9.5mm (3/8")	1.30 x 0.60mm (0.051" x 0.024")	200	20 GA. Senco G
USA1116A / USA1116ALM	10.8mm (7/16")	1.22 x 0.50mm (0.048" x 0.020")	200	20 GA. Fasco A11 / Arrow T50
US1013FA / US1013FALM	11.2mm (7/16")	0.70 x 0.50mm (0.028" x 0.020")	300	23 GA. MAX 10F (1000F)
US1013JA / US1013JALM	11.2mm (7/16")	1.20 x 0.60mm (0.047" x 0.024")	200	20 GA. MAX 10J (1000J)
US8416A / US8416ALM	12.3mm (1/2")	1.00 x 0.55mm (0.039" x 0.022")	200	21 GA. Bostitch SBNK / Fasco 84
US6416A / US6416ALM	12.45mm (1/2")	0.73 x 0.51mm (0.030" x 0.024")	300	22 GA. Atro 6 / BeA 64
US50(95)16A / US50(95)16ALM	12.55mm (1/2")	1.25mm x 0.50 (0.050" x 0.020")	200	20 GA. Duo-Fast 50 / BeA 95
US8016A / US8016ALM	12.8mm (1/2")	0.90mm x 0.63 (0.036" x 0.025")	270	21 GA. 80 Series / Senco AT
USSNCF16A / USSNCF16ALM	12.8mm (1/2")	1.25mm x 0.50 (0.049" x 0.020")	200	20 GA. Senco F / Prebena P



- 1 DEPTH OF CLINCH AND PENETRATION ADJUSTABLE
- 2 LOW NOISE ENGINE
- 3 ALL METAL CONSTRUCTION

- 200+ CARTONS PER HOUR
- LIGHT WEIGHT AND WELL BALANCED
- IDEAL FOR HIGH VOLUME PRODUCTION

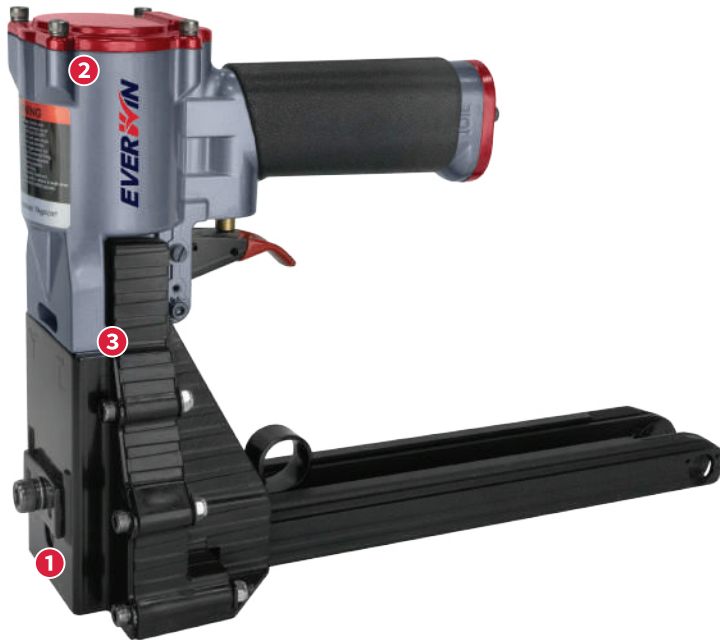

### FASTENER SPECIFICATION

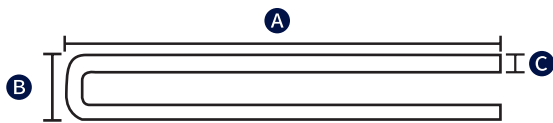

### TOOL SPECIFICATION

Weight	2.06 kgs (4.5 lbs)
Height	220mm (8.7")
Width	115mm (4.5")
Length	340mm (13.4")
Operating Pressure	5~6.9 bar (70~100 psi)
Air Consumption L/cycle @90 psi	0.5 (1.05 cfm)
Applications	Carton Box Sealing

Model Number	Staple Type	Loading Capacity	A	B	C
CCA-19-34	34mm (1-3/8") Crown Carton Staples	100	16 & 19mm (5/8" & 3/4")	34mm (1-3/8")	2.3 x 0.9mm (0.090" x 0.035")
CCA-22-35	34.7mm (1-3/8") Crown Carton Staples	100	18 & 22mm (3/4" & 7/8")	34.7mm (1-3/8")	2.3 x 0.9mm (0.090" x 0.035")
CCA-19-32	32mm (1-1/4") Crown Carton Staples	100	15 & 18mm (5/8" & 3/4")	32mm (1-1/4")	1.9 x 0.9mm (0.075" x 0.035")
CCA19-7437	Bostitch SW7437 Type Carton Staples	100	15 & 18mm (5/8" & 3/4")	34.5mm (1-11/32")	1.9 x 0.9mm (0.075" x 0.035")
CCA-19-9040	Bostitch SW9040 Type Carton Staples	100	15 & 18mm (5/8" & 3/4")	34.5mm (1-11/32")	2.3 x 0.9mm (0.090" x 0.035")
CCA-22-9040	Bostitch SW9040 Type Carton Staples	100	18 & 22mm (3/4" & 7/8")	34.7mm (1-3/8")	2.3 x 0.9mm (0.090" x 0.035")

- 1 DEPTH OF CLINCH AND PENETRATION ADJUSTABLE
- 2 ALL METAL CONSTRUCTION
- 3 TAKES 1000 STAPLES PER LOAD
- 4 LOW NOISE ENGINE
- LIGHT WEIGHT AND WELL BALANCED
- IDEAL FOR HIGH VOLUME PRODUCTION



**FASTENER SPECIFICATION**

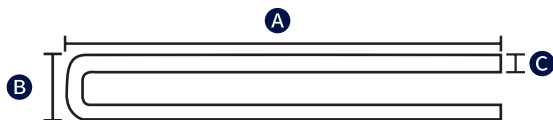

**TOOL SPECIFICATION**

Weight	2.4 kgs (5.2 lbs)
Height	230mm (9.1")
Width	115mm (4.5")
Length	233mm (9.2")
Operating Pressure	5~6.9 bar (70~100 psi)
Air Consumption L/cycle @90 psi	0.5 (1.05 cfm)
Applications	Carton Box Sealing

Model Number	Staple Type	Loading Capacity	A	B	C
RCC19-RR	Roll Stapler I-PR	1000	15 & 18mm (5/8" & 3/4")	32mm (1-1/4")	1.9 x 0.9mm (0.075" x 0.035")
RCC-19-GR	Roll Stapler I-GR	1000	15 & 18mm (5/8" & 3/4")	34.7mm (1-3/8")	2.3 x 0.9mm (0.090" x 0.035")
RCC-22-GR	Roll Stapler I-PR	1000	18 & 22mm (3/4" & 7/8")	32mm (1-1/4")	2.3 x 0.9mm (0.090" x 0.035")
RCC-19-SWC	Roll Stapler SWC	1000	15 & 18mm (5/8" & 3/4")	34mm (1-3/8")	1.9 x 0.9mm (0.075" x 0.035")
RCC-19-555	Roll Stapler JK555	1000	15 & 18mm (5/8" & 3/4")	32mm (1-1/4")	2.3 x 1.4mm (0.090" x 0.055")

# HR7 Series

Hog Ring Plier

# HR760 / 761

Hog Ring Plier



Model #	Nose Length
HR7	25mm (1")
HR7E	40mm (1.6")
HR77XE	70mm (2.8")

- 1 ALL METAL CONSTRUCTION
- 2 3 NOSE LENGTHS AVAILABLE
- 3 PNEUMATIC PISTON RETURN MINIMIZES CYCLE TIME
- 4 ADJUSTABLE FOR LEFT OR RIGHT HANDED OPERATION



FASTENER SPECIFICATION	
Type	15 GA. Bostitch RING15 Meihotech GDH
Wire Diameter	1.8mm (0.07")
Crown Width	23.9mm (15/16")
Ring Height	12mm (1/2")
Open Ring Size	19mm (3/4")
Closure Ring Size	7.9~10.7mm (5/16"~27/64")
Tip Finish	Sharp or Blunt
Load Capacity	100 Rings

TOOL SPECIFICATION	
Weight	HR7: 1.39 kgs (3.0 lbs) HR7E: 1.53 kgs (3.4 lbs) HR77XE: 1.72 kgs (3.8 lbs)
Height	189mm (7.4")
Width	89mm (3.5")
Length	HR7: 335mm (13.2") HR7E: 354mm (13.9") HR77XE: 381mm (15")
Operating Pressure:	5.9~7.9 bars (85 to 115 PSI)
Applications	Bag Closure, Bedding Automotive Seating Wire Cages, Fencing



- 1 ALL METAL CONSTRUCTION
- 2 PNEUMATIC PISTON RETURN MINIMIZES CYCLE TIME
- 3 2 CLOSURE RING SIZES AVAILABLE
- 4 ADJUSTABLE FOR LEFT OR RIGHT HANDED OPERATION



FASTENER SPECIFICATION	
Type	16 GA. Meihotech 47ALD Bostitch RING516G100
Wire Diameter	1.6mm (0.063")
Crown Width	16.8mm (21/32")
Ring Height	9mm (3/8")
Open Ring Size	12.5mm (1/2")
Closure Ring Size	HR760: 3.2~5.6mm (1/8"~7/32") HR761: 4.8~5.6mm (3/16"~7/32")
Tip Finish	Sharp or Blunt
Load Capacity	100 Rings

TOOL SPECIFICATION	
Weight	1.39 kgs (3.0 lbs)
Height	189mm (7.4")
Width	89mm (3.5")
Length	335mm (13.2")
Operating Pressure:	5.9~7.9 bars (85 to 115 PSI)
Applications	Bag Closure, Bedding Automotive Seating Wire Cages, Fencing

# EVEREST



บริษัท นานตีอินเตอร์เทรด จำกัด  
**NANDEE INTER-TRADE CO., LTD.**

314,316,318,320,322 ซอยจันทน์ 32 ถนนจันทน์ แขวงทุ่งวัดดอน เขตสาทร กทม. 10120

☎ : 0-2675-8239  
LINE : @nandeeintertrade  
f : nandeeintertrade  
🌐 : www.nandee.co.th  
✉ : marketing@nandee.co.th  
sales@nandee.co.th